

NBG-416N

Wireless N-lite Home Router

User's Guide



Default Login Details

IP Address	http://192.168.1.1
Username	admin
Password	1234

Firmware Version 1.0
Edition 1, 1/2011

www.zyxel.com

ZyXEL

About This User's Guide

Intended Audience

This manual is intended for people who want to configure the NBG-416N using the Web Configurator. You should have at least a basic knowledge of TCP/IP networking concepts and topology.

Tips for Reading User's Guides On-Screen

When reading a ZyXEL User's Guide On-Screen, keep the following in mind:

- If you don't already have the latest version of Adobe Reader, you can download it from <http://www.adobe.com>.
- Use the PDF's bookmarks to quickly navigate to the areas that interest you. Adobe Reader's bookmarks pane opens by default in all ZyXEL User's Guide PDFs.
- If you know the page number or know vaguely which page-range you want to view, you can enter a number in the toolbar in Reader, then press [ENTER] to jump directly to that page.
- Type [CTRL]+[F] to open the Adobe Reader search utility and enter a word or phrase. This can help you quickly pinpoint the information you require. You can also enter text directly into the toolbar in Reader.
- To quickly move around within a page, press the [SPACE] bar. This turns your cursor into a "hand" with which you can grab the page and move it around freely on your screen.
- Embedded hyperlinks are actually cross-references to related text. Click them to jump to the corresponding section of the User's Guide PDF.

Related Documentation

- Quick Start Guide

The Quick Start Guide is designed to help you get your NBG-416N up and running right away. It contains information on setting up your network and configuring for Internet access.

- Supporting Disc

The embedded Web Help contains descriptions of individual screens and supplementary information.

- Support Disc

Refer to the included CD for support documents.

Documentation Feedback

Send your comments, questions or suggestions to: techwriters@zyxel.com.tw

Thank you!

The Technical Writing Team, ZyXEL Communications Corp.,
6 Innovation Road II, Science-Based Industrial Park, Hsinchu, 30099, Taiwan.

Need More Help?

More help is available at www.zyxel.com.

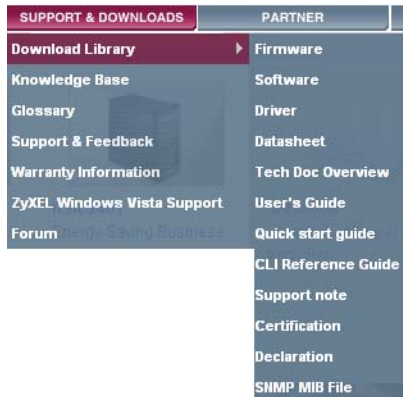

- **Download Library**
Search for the latest product updates and documentation from this link. Read the Tech Doc Overview to find out how to efficiently use the User Guide, Quick Start Guide and Command Line Interface Reference Guide in order to better understand how to use your product.
- **Knowledge Base**
If you have a specific question about your product, the answer may be here. This is a collection of answers to previously asked questions about ZyXEL products.
- **Forum**
This contains discussions on ZyXEL products. Learn from others who use ZyXEL products and share your experiences as well.

Customer Support

Should problems arise that cannot be solved by the methods listed above, you should contact your vendor. If you cannot contact your vendor, then contact a ZyXEL office for the region in which you bought the device.

See http://www.zyxel.com/web/contact_us.php for contact information. Please have the following information ready when you contact an office.

- Product model and serial number.
- Warranty Information.
- Date that you received your device.

Document Conventions

Warnings and Notes

These are how warnings and notes are shown in this User's Guide.

Warnings tell you about things that could harm you or your device.









Note: Notes tell you other important information (for example, other things you may need to configure or helpful tips) or recommendations.

Syntax Conventions

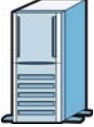
- The NBG-416N may be referred to as the "NBG-416N", the "device", the "product" or the "system" in this User's Guide.
- Product labels, screen names, field labels and field choices are all in **bold** font.
- A key stroke is denoted by square brackets and uppercase text, for example, [ENTER] means the "enter" or "return" key on your keyboard.
- "Enter" means for you to type one or more characters and then press the [ENTER] key. "Select" or "choose" means for you to use one of the predefined choices.
- A right angle bracket (>) within a screen name denotes a mouse click. For example, **Maintenance > Log > Log Setting** means you first click **Maintenance** in the navigation panel, then the **Log** sub menu and finally the **Log Setting** tab to get to that screen.
- Units of measurement may denote the "metric" value or the "scientific" value. For example, "k" for kilo may denote "1000" or "1024", "M" for mega may denote "1000000" or "1048576" and so on.
- "e.g.," is a shorthand for "for instance", and "i.e.," means "that is" or "in other words".

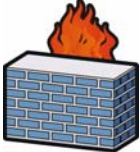
Icons Used in Figures

Figures in this User's Guide may use the following generic icons. The NBG-416N icon is not an exact representation of your device.

NBG-416N 	Computer 	Notebook computer 
Server 	Modem 	Firewall 
Telephone 	Switch 	Router 

Safety Warnings

- Do NOT use this product near water, for example, in a wet basement or near a swimming pool.
- Do NOT expose your device to dampness, dust or corrosive liquids.
- Do NOT store things on the device.
- Do NOT install, use, or service this device during a thunderstorm. There is a remote risk of electric shock from lightning.
- Connect ONLY suitable accessories to the device.
- Do NOT open the device or unit. Opening or removing covers can expose you to dangerous high voltage points or other risks. ONLY qualified service personnel should service or disassemble this device. Please contact your vendor for further information.
- Make sure to connect the cables to the correct ports.
- Place connecting cables carefully so that no one will step on them or stumble over them.
- Always disconnect all cables from this device before servicing or disassembling.
- Use ONLY an appropriate power adaptor or cord for your device.
- Connect the power adaptor or cord to the right supply voltage (for example, 110V AC in North America or 230V AC in Europe).
- Do NOT allow anything to rest on the power adaptor or cord and do NOT place the product where anyone can walk on the power adaptor or cord.
- Do NOT use the device if the power adaptor or cord is damaged as it might cause electrocution.
- If the power adaptor or cord is damaged, remove it from the power outlet.
- Do NOT attempt to repair the power adaptor or cord. Contact your local vendor to order a new one.
- Do not use the device outside, and make sure all the connections are indoors. There is a remote risk of electric shock from lightning.
- Do NOT obstruct the device ventilation slots, as insufficient airflow may harm your device.
- Antenna Warning! This device meets ETSI and FCC certification requirements when using the included antenna(s). Only use the included antenna(s).
- If you wall mount your device, make sure that no electrical lines, gas or water pipes will be damaged.

Your product is marked with this symbol, which is known as the WEEE mark. WEEE stands for Waste Electronics and Electrical Equipment. It means that used electrical and electronic products should not be mixed with general waste. Used electrical and electronic equipment should be treated separately.



Contents Overview

User's Guide	17
Introduction	19
The WPS Button	23
The Web Configurator	25
Connection Wizard	35
AP Mode	49
Tutorials	57
Technical Reference	65
Wireless LAN	67
WAN	83
LAN	91
DHCP Server	95
Network Address Translation (NAT)	101
Firewall	109
Remote Management	113
Universal Plug-and-Play (UPnP)	117
System	125
Logs	131
Tools	133
Sys OP Mode	139
Language	143
Troubleshooting	145
Product Specifications	153

Table of Contents

About This User's Guide	3
Document Conventions.....	6
Safety Warnings.....	8
Contents Overview	9
Table of Contents.....	11
Part I: User's Guide.....	17
Chapter 1	
Introduction.....	19
1.1 Overview	19
1.2 Applications	19
1.3 Ways to Manage the NBG-416N	20
1.4 Good Habits for Managing the NBG-416N	20
1.5 LEDs	20
Chapter 2	
The WPS Button.....	23
2.1 Overview	23
Chapter 3	
The Web Configurator	25
3.1 Overview	25
3.2 Accessing the Web Configurator	25
3.3 Resetting the NBG-416N	27
3.3.1 Using the RESET Button	27
3.4 Navigating the Web Configurator	27
3.5 Status Screen (Router Mode)	28
3.5.1 Navigation Panel	30
3.5.2 Summary: DHCP Table	32
3.5.3 Summary: Packet Statistics	33
3.5.4 Summary: WLAN Station Status	34
Chapter 4	
Connection Wizard	35

4.1 Wizard Setup	35
4.2 Connection Wizard: STEP 1: System Information	36
4.2.1 System Name	36
4.2.2 Domain Name	37
4.3 Connection Wizard: STEP 2: Wireless LAN	38
4.3.1 Extend (WPA-PSK or WPA2-PSK) Security	39
4.4 Connection Wizard: STEP 3: Internet Configuration	39
4.4.1 Ethernet Connection	40
4.4.2 PPPoE Connection	40
4.4.3 PPTP Connection	42
4.4.4 Your IP Address	43
4.4.5 WAN IP Address Assignment	44
4.4.6 IP Address and Subnet Mask	44
4.4.7 DNS Server Address Assignment	45
4.4.8 WAN IP and DNS Server Address Assignment	46
4.4.9 WAN MAC Address	47
4.5 Connection Wizard Complete	48
Chapter 5	
AP Mode.....	49
5.1 Overview	49
5.2 Setting your NBG-416N to AP Mode	49
5.3 Status Screen (AP Mode)	50
5.3.1 Navigation Panel	52
5.4 Configuring Your Settings	53
5.4.1 LAN Settings	53
5.4.2 WLAN and Maintenance Settings	54
5.5 Logging in to the Web Configurator in AP Mode	54
Chapter 6	
Tutorials.....	57
6.1 Overview	57
6.2 How to Connect to the Internet from an AP	57
6.2.1 Configure Wireless Security Using WPS on both your NBG-416N and Wireless Client	57
6.3 Enable and Configure Wireless Security without WPS on your NBG-416N	61
 Part II: Technical Reference	 65
Chapter 7	
Wireless LAN.....	67
7.1 Overview	67

7.2 What You Can Do	68
7.3 What You Should Know	68
7.3.1 Wireless Security Overview	68
7.4 General Wireless LAN Screen	71
7.4.1 No Security	72
7.4.2 WEP Encryption	73
7.4.3 WPA-PSK/WPA2-PSK	75
7.5 MAC Filter	76
7.6 Wireless LAN Advanced Screen	77
7.7 Quality of Service (QoS) Screen	79
7.8 WPS Screen	80
7.9 WPS Station Screen	81
7.10 Scheduling Screen	81
Chapter 8	
WAN.....	83
8.1 Overview	83
8.2 What You Need To Know	83
8.2.1 Configuring Your Internet Connection	84
8.3 Internet Connection	85
8.3.1 Ethernet Encapsulation	85
8.3.2 PPPoE Encapsulation	87
8.3.3 PPTP Encapsulation	88
Chapter 9	
LAN.....	91
9.1 Overview	91
9.2 What You Need To Know	92
9.2.1 IP Pool Setup	92
9.2.2 LAN TCP/IP	92
9.3 LAN IP Screen	93
Chapter 10	
DHCP Server.....	95
10.1 Overview	95
10.2 What You Can Do	95
10.3 What You Need To Know	95
10.4 General Screen	96
10.5 Advanced Screen	96
10.6 Client List Screen	98
Chapter 11	
Network Address Translation (NAT).....	101

11.1 Overview	101
11.2 What You Can Do	102
11.2.1 What You Need To Know	102
11.3 General NAT Screen	104
11.4 NAT Application Screen	105
11.5 Technical Reference	107
11.5.1 NAT Port Forwarding: Services and Port Numbers	107
11.5.2 NAT Port Forwarding Example	108
Chapter 12	
Firewall.....	109
12.1 Overview	109
12.2 What You Can Do	109
12.3 What You Need To Know	110
12.3.1 About the NBG-416N Firewall	110
12.3.2 VPN Pass Through Features	110
12.4 General Firewall Screen	111
12.5 Services Screen	111
Chapter 13	
Remote Management.....	113
13.1 Overview	113
13.2 What You Need To Know	113
13.2.1 Remote Management Limitations	114
13.2.2 Remote Management and NAT	114
13.2.3 System Timeout	114
13.3 WWW Screen	115
Chapter 14	
Universal Plug-and-Play (UPnP).....	117
14.1 Overview	117
14.2 What You Need to Know	117
14.3 UPnP Screen	118
14.4 Technical Reference	119
14.4.1 Using UPnP in Windows XP Example	119
14.4.2 Web Configurator Easy Access	122
Chapter 15	
System.....	125
15.1 Overview	125
15.2 What You Can Do	125
15.3 System General Screen	125
15.4 Time Setting Screen	127

Chapter 16	
Logs	131
16.1 Overview	131
16.2 What You Need to Know	131
16.3 View Log Screen	131
Chapter 17	
Tools	133
17.1 Overview	133
17.2 What You Can Do	133
17.3 Firmware Upload Screen	133
17.4 Configuration Screen	136
17.4.1 Backup Configuration	136
17.4.2 Restore Configuration	137
17.4.3 Back to Factory Defaults	138
17.5 Restart Screen	138
Chapter 18	
Sys OP Mode	139
18.1 Overview	139
18.2 What You Need to Know	139
18.3 General Screen	140
Chapter 19	
Language	143
19.1 Language Screen	143
Chapter 20	
Troubleshooting	145
20.1 Power, Hardware Connections, and LEDs	145
20.2 NBG-416N Access and Login	146
20.3 Internet Access	148
20.4 Resetting the NBG-416N to Its Factory Defaults	149
20.5 Wireless Router/AP Troubleshooting	150
Chapter 21	
Product Specifications	153
Appendix A IP Addresses and Subnetting	157
Appendix B Pop-up Windows, JavaScript and Java Permissions.....	167
Appendix C Setting up Your Computer's IP Address	175
21.0.1 Verifying Settings	192

Appendix D Wireless LANs 193
 21.0.2 WPA(2)-PSK Application Example 203
 21.0.3 WPA(2) with RADIUS Application Example 203

Appendix E Services 205

Appendix F Open Software Announcements 209

Appendix G Legal Information 231

Index..... 239

PART I

User's Guide

Introduction

1.1 Overview

This chapter introduces the main features and applications of the NBG-416N.

The NBG-416N extends the range of your existing wired network without additional wiring, providing easy network access to mobile users. You can set up a wireless network with other IEEE 802.11b/g/n compatible devices.

A range of services such as a firewall and content filtering are also available for secure Internet computing.

1.2 Applications

You can create the following networks using the NBG-416N:

- **Wired.** You can connect network devices via the Ethernet ports of the NBG-416N so that they can communicate with each other and access the Internet.
- **Wireless.** Wireless clients can connect to the NBG-416N to access network resources.
- **WAN.** Connect to a broadband modem/router for Internet access.

Figure 1 NBG-416N Network

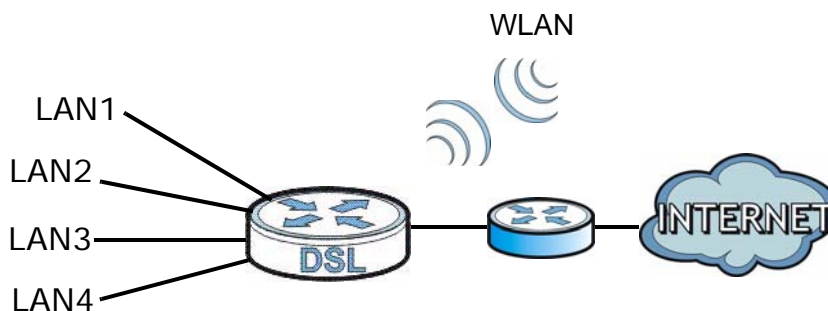

1.3 Ways to Manage the NBG-416N

Use any of the following methods to manage the NBG-416N.

- WPS (Wi-Fi Protected Setup). You can use the WPS button or the WPS section of the Web Configurator to set up a wireless network with your ZyXEL Device.
- Web Configurator. This is recommended for everyday management of the NBG-416N using a (supported) web browser.

1.4 Good Habits for Managing the NBG-416N

Do the following things regularly to make the NBG-416N more secure and to manage the NBG-416N more effectively.

- Change the password. Use a password that's not easy to guess and that consists of different types of characters, such as numbers and letters.
- Write down the password and put it in a safe place.
- Back up the configuration (and make sure you know how to restore it). Restoring an earlier working configuration may be useful if the device becomes unstable or even crashes. If you forget your password, you will have to reset the NBG-416N to its factory default settings. If you backed up an earlier configuration file, you would not have to totally re-configure the NBG-416N. You could simply restore your last configuration.

1.5 LEDs

Figure 2 Front Panel



The following table describes the LEDs and the WPS button.

Table 1 Front Panel LEDs and WPS Button

LED	COLOR	STATUS	DESCRIPTION
	Green	On	The NBG-416N is receiving power and functioning properly.
		Off	The NBG-416N is not receiving power.

Table 1 Front Panel LEDs and WPS Button (continued)

LED	COLOR	STATUS	DESCRIPTION
LAN 1-4 	Green	On	The NBG-416N has a successful 10/100MB LAN connection.
		Blinking	The NBG-416N is sending/receiving data through the LAN.
		Off	The LAN is not connected.
WAN 	Green	On	The NBG-416N has a successful 10/100MB WAN connection.
		Blinking	The NBG-416N is sending/receiving data through the WAN.
		Off	The WAN connection is not ready, or has failed.
WLAN 	Green	On	The NBG-416N is ready, but is not sending/receiving data through the wireless LAN.
		Blinking	The NBG-416N is sending/receiving data through the wireless LAN. The NBG-416N is negotiating a WPS connection with a wireless client.
		Off	The wireless LAN is not ready or has failed.
WPS 	Green	On	WPS status is configured.
		Blinking	The NBG-416N is negotiating a WPS connection with a wireless client.
		Off	The WPS status is not configured or disabled.

The WPS Button

2.1 Overview

Your NBG-416N supports WiFi Protected Setup (WPS), which is an easy way to set up a secure wireless network. WPS is an industry standard specification, defined by the WiFi Alliance.

WPS allows you to quickly set up a wireless network with strong security, without having to configure security settings manually. Each WPS connection works between two devices. Both devices must support WPS (check each device's documentation to make sure).

Depending on the devices you have, you can either press a button (on the device itself, or in its configuration utility) or enter a PIN (a unique Personal Identification Number that allows one device to authenticate the other) in each of the two devices. When WPS is activated on a device, it has two minutes to find another device that also has WPS activated. Then, the two devices connect and set up a secure network by themselves.

For more information on using WPS, see [Section 6.2.1 on page 57](#).

The Web Configurator

3.1 Overview

This chapter describes how to access the NBG-416N Web Configurator and provides an overview of its screens.

The Web Configurator is an HTML-based management interface that allows easy setup and management of the NBG-416N via Internet browser. Use Internet Explorer 6.0 and later versions, Mozilla Firefox 3 and later versions, or Safari 2.0 and later versions. The recommended screen resolution is 1024 by 768 pixels.

In order to use the Web Configurator you need to allow:

- Web browser pop-up windows from your device. Web pop-up blocking is enabled by default in Windows XP SP (Service Pack) 2.
- JavaScript (enabled by default).
- Java permissions (enabled by default).

Refer to [Chapter 20 Troubleshooting](#) to see how to make sure these functions are allowed in Internet Explorer.

3.2 Accessing the Web Configurator

- 1 Make sure your NBG-416N hardware is properly connected and prepare your computer or computer network to connect to the NBG-416N (refer to the Quick Start Guide).
- 2 Launch your web browser.
- 3 Type "http://192.168.1.1" as the website address.

Your computer must be in the same subnet in order to access this website address.

- 4 Type **admin** (default) as the user name and **1234** (default) as the password and click **OK**.

Figure 3 Login Screen

- 5 You should see a screen asking you to change your password (highly recommended) as shown next. Type a new password (and retype it to confirm) and click **Apply** or click **Ignore**.

Figure 4 Change Password Screen

Note: The management session automatically times out when the time period set in the **Administrator Inactivity Timer** field expires (default five minutes). Simply log back into the NBG-416N if this happens.

- 6 Select the setup mode you want to use.
 - Click **Go to Wizard Setup** to use the Configuration Wizard for basic Internet and Wireless setup.
 - Click **Go to Advanced Setup** to view and configure all the NBG-416N's settings.

- Select a language to go to the basic Web Configurator in that language. To change to the advanced configurator see [Chapter 19 on page 143](#).

Figure 5 Selecting the setup mode

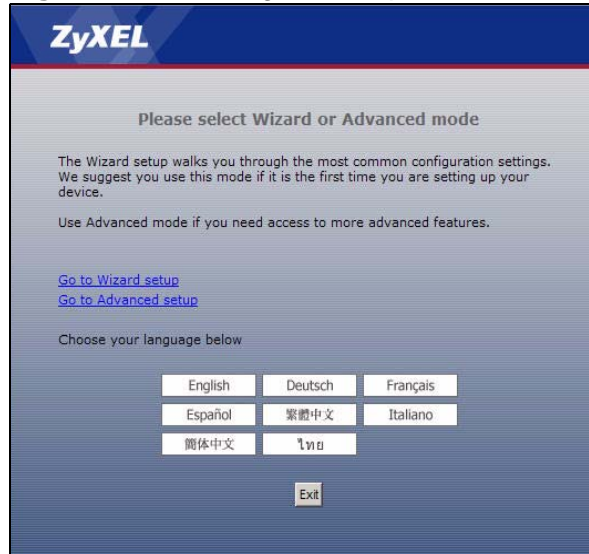

3.3 Resetting the NBG-416N

If you forget your password or IP address, or you cannot access the Web Configurator, you will need to use the **RESET** button at the back of the NBG-416N to reload the factory-default configuration file. This means that you will lose all configurations that you had previously saved, the username will be reset to **admin** and password will be reset to **1234**. The IP address will be reset to "192.168.1.1".

3.3.1 Using the RESET Button

- 1 Make sure the power LED is on.
- 2 Press the **RESET** button for longer than 1 second to restart/reboot the NBG-416N.
- 3 Press the **RESET** button for longer than five seconds to set the NBG-416N back to its factory-default configurations.

3.4 Navigating the Web Configurator

The following summarizes how to navigate the Web Configurator from the **Status** screen in **Router Mode** and **AP Mode**.

3.5 Status Screen (Router Mode)



Click on **Status**. The screen below shows the status screen in **Router Mode**.

(For information on the status screen in **AP Mode** see [Chapter 5 on page 50.](#))

Figure 6 Status Screen (Router Mode)

The following table describes the icons shown in the **Status** screen.

Table 2 Status Screen Icon Key

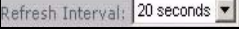
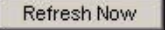
ICON	DESCRIPTION
	Click this icon to open the setup wizard.
	Click this icon to view copyright and a link for related product information.
	Click this icon at any time to exit the Web Configurator.
	Select a number of seconds or None from the drop-down list box to refresh all screen statistics automatically at the end of every time interval or to not refresh the screen statistics.
	Click this button to refresh the status screen statistics.

The following table describes the labels shown in the **Status** screen.

Table 3 Web Configurator Status Screen (Router Mode)

LABEL	DESCRIPTION
Device Information	
System Name	This is the System Name you enter in the Maintenance > System > General screen. It is for identification purposes.
Firmware Version	This is the current firmware version of the NBG-416N.
WAN Information	
- MAC Address	This shows the WAN Ethernet adapter MAC Address of your device.
- Connection Type	This shows the current connection type.
- IP Address	This shows the WAN port's IP address.
- IP Subnet Mask	This shows the WAN port's subnet mask.
- Gateway	This shows the WAN port's gateway IP address.
- DNS	This shows the IP address of your DNS server.
LAN Information	
- MAC Address	This shows the LAN Ethernet adapter MAC Address of your device.
- IP Address	This shows the LAN port's IP address.
- IP Subnet Mask	This shows the LAN port's subnet mask.
- DHCP	This shows the LAN port's DHCP role - Server or None .
WLAN Information	
- MAC Address	This shows the wireless adapter MAC Address of your device.
- Status	This shows the current status of the Wireless LAN - On , Off or Off by scheduler .
- Name (SSID)	This shows a descriptive name used to identify the NBG-416N in the wireless LAN.
- Channel	This shows the channel number which you select manually.
- Security Mode	This shows the level of wireless security the NBG-416N is using.
- 802.11 Mode	This shows the wireless standard.
- WPS	This displays Configured when the WPS has been set up. This displays Unconfigured if the WPS has not been set up. Click the status to display Network > Wireless LAN > WPS screen.
System Status	
System Up Time	This is the total time the NBG-416N has been on.
Current Date/Time	This field displays your NBG-416N's present date and time.
System Resource	
- CPU Usage	This displays what percentage of the NBG-416N's processing ability is currently used. When this percentage is close to 100%, the NBG-416N is running at full load, and the throughput is not going to improve anymore. If you want some applications to have more throughput, you should turn off other applications.
- Memory Usage	This shows what percentage of the heap memory the NBG-416N is using.

Table 3 Web Configurator Status Screen (Router Mode) (continued)

LABEL	DESCRIPTION
System Setting	
- Firewall	This shows whether the firewall is active or not.
- UPnP	This shows whether UPnP is active or not.
Interface Status	
Interface	This displays the NBG-416N port types. The port types are: WAN , LAN and WLAN .
Status	For the LAN and WAN ports, this field displays Down (line is down) or Up (line is up or connected). For the WLAN, it displays Up when the WLAN is enabled or Down when the WLAN is disabled.
Rate	For the LAN ports, this displays the port speed and duplex setting or N/A when the line is disconnected. For the WAN port, it displays the port speed and duplex setting if you're using Ethernet encapsulation and Idle (line (ppp) idle), Dial (starting to trigger a call) and Drop (dropping a call) if you're using PPPoE or PPTP encapsulation. This field displays N/A when the line is disconnected. For the WLAN, it displays the maximum transmission rate when the WLAN is enabled and N/A when the WLAN is disabled.
Summary	
DHCP Table	Use this screen to view current DHCP client information.
Packet Statistics	Use this screen to view port status and packet specific statistics.
WLAN Station Status	Use this screen to view the wireless stations that are currently associated to the NBG-416N.

3.5.1 Navigation Panel

Use the sub-menus on the navigation panel to configure NBG-416N features.

The following table describes the sub-menus.

Table 4 Screens Summary

LINK	TAB	FUNCTION
Status		This screen shows the NBG-416N's general device, system and interface status information. Use this screen to access the wizard, and summary statistics tables.
Network		

Table 4 Screens Summary (continued)

LINK	TAB	FUNCTION
Wireless LAN	General	Use this screen to configure wireless LAN.
	MAC Filter	Use the MAC filter screen to configure the NBG-416N to block access to devices or block the devices from accessing the NBG-416N.
	Advanced	This screen allows you to configure advanced wireless settings.
	QoS	Use this screen to configure Wi-Fi Multimedia Quality of Service (WMM QoS). WMM QoS allows you to prioritize wireless traffic according to the delivery requirements of individual services.
	WPS	Use this screen to configure WPS.
	WPS Station	Use this screen to add a wireless station using WPS.
	Scheduling	Use this screen to schedule the times the Wireless LAN is enabled.
WAN	Internet Connection	This screen allows you to configure ISP parameters, WAN IP address assignment, DNS servers and the WAN MAC address.
LAN	IP	Use this screen to configure LAN IP address and subnet mask.
DHCP Server	General	Use this screen to enable the NBG-416N's DHCP server.
	Advanced	Use this screen to assign IP addresses to specific individual computers based on their MAC addresses and to have DNS servers assigned by the DHCP server.
	Client List	Use this screen to view current DHCP client information and to always assign an IP address to a MAC address (and host name).
NAT	General	Use this screen to enable NAT.
	Application	Use this screen to configure servers behind the NBG-416N.
Security		
Firewall	General	Use this screen to activate/deactivate the firewall.
	Services	Use this screen to enable or disable ICMP and VPN passthrough features.
Management		
Remote MGMT	WWW	Use this screen to configure through which interface(s) and from which IP address(es) users can use HTTP to manage the NBG-416N.
UPnP	General	Use this screen to enable UPnP on the NBG-416N.
Maintenance		
System	General	Use this screen to view and change administrative settings such as system and domain names, password and inactivity timer.
	Time Setting	Use this screen to change your NBG-416N's time and date.
Logs	View Log	Use this screen to view the logs for the categories that you selected.

Table 4 Screens Summary (continued)

LINK	TAB	FUNCTION
Tools	Firmware	Use this screen to upload firmware to your NBG-416N.
	Configuration	Use this screen to backup and restore the configuration or reset the factory defaults to your NBG-416N.
	Restart	This screen allows you to reboot the NBG-416N without turning the power off.
Sys OP Mode	General	This screen allows you to select whether your device acts as a Router or a Access Point.
Language	Language	This screen allows you to select the language you prefer.

3.5.2 Summary: DHCP Table

DHCP (Dynamic Host Configuration Protocol, RFC 2131 and RFC 2132) allows individual clients to obtain TCP/IP configuration at start-up from a server. You can configure the NBG-416N's LAN as a DHCP server or disable it. When configured as a server, the NBG-416N provides the TCP/IP configuration for the clients. If DHCP service is disabled, you must have another DHCP server on that network, or else the computer must be manually configured.

Click the **DHCP Table (Details...)** hyperlink in the **Status** screen. Read-only information here relates to your DHCP status. The DHCP table shows current DHCP client information (including **IP Address**, **Host Name** and **MAC Address**) of all network clients using the NBG-416N's DHCP server.

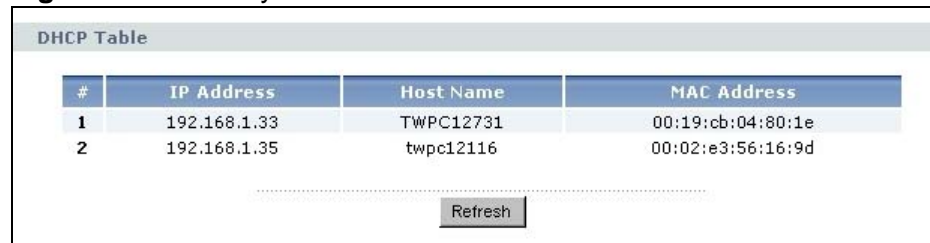
Figure 7 Summary: DHCP Table

DHCP Table			
#	IP Address	Host Name	MAC Address
1	192.168.1.33	TWPC12731	00:19:cb:04:80:1e
2	192.168.1.35	twpc12116	00:02:e3:56:16:9d

Refresh

The following table describes the labels in this screen.

Table 5 Summary: DHCP Table

LABEL	DESCRIPTION
#	This is the index number of the host computer.
IP Address	This field displays the IP address relative to the # field listed above.
Host Name	This field displays the computer host name.

Table 5 Summary: DHCP Table (continued)

LABEL	DESCRIPTION
MAC Address	This field shows the MAC address of the computer with the name in the Host Name field. Every Ethernet device has a unique MAC (Media Access Control) address which uniquely identifies a device. The MAC address is assigned at the factory and consists of six pairs of hexadecimal characters, for example, 00:AO:C5:00:00:02.
Refresh	Click Refresh to renew the screen.

3.5.3 Summary: Packet Statistics

Click the **Packet Statistics (Details...)** hyperlink in the **Status** screen. Read-only information here includes port status, packet specific statistics and the "system up time". The **Poll Interval(s)** field is configurable and is used for refreshing the screen.

Figure 8 Summary: Packet Statistics

Packet Statistics						
Port	Status	TxPkts	RxPkts	Collisions	Tx B/s	Rx B/s
WAN	100M	876235	809818	0	0	150
LAN	100M	810753	886992	0	821	1676
WLAN	N/A	958	3019	0	0	0

System Up Time : 1:41:47

Poll Interval : sec

The following table describes the labels in this screen.

Table 6 Summary: Packet Statistics

LABEL	DESCRIPTION
Port	This is the NBG-416N's port type.
Status	For the LAN ports, this displays the port speed and duplex setting or Down when the line is disconnected. For the WAN port, it displays the port speed and duplex setting if you're using Ethernet encapsulation and Idle (line (ppp) idle), Dial (starting to trigger a call) and Drop (dropping a call) if you're using PPPoE or PPTP encapsulation. This field displays Down when the line is disconnected. For the WLAN, it displays the maximum transmission rate when the WLAN is enabled and Down when the WLAN is disabled.
TxPkts	This is the number of transmitted packets on this port.
RxPkts	This is the number of received packets on this port.
Collisions	This is the number of collisions on this port.

Table 6 Summary: Packet Statistics (continued)

LABEL	DESCRIPTION
Tx B/s	This displays the transmission speed in bytes per second on this port.
Rx B/s	This displays the reception speed in bytes per second on this port.
System Up Time	This is the total time the NBG-416N has been on.
Poll Interval(s)	Enter the time interval for refreshing statistics in this field.
Set Interval	Click this button to apply the new poll interval you entered in the Poll Interval(s) field.
Stop	Click Stop to stop refreshing statistics.

3.5.4 Summary: WLAN Station Status

Click the **WLAN Station Status (Details...)** hyperlink in the **Status** screen. View the wireless stations that are currently associated to the NBG-416N in the **Association List**. Association means that a wireless client (for example, your network or computer with a wireless network card) has connected successfully to the AP (or wireless router) using the same SSID, channel and security settings.

Figure 9 Summary: Wireless Association List

Association List		
#	MAC Address	Association Time
1	00:19:cb:04:80:1e	03:52:42 2000/01/01

Refresh

The following table describes the labels in this screen.

Table 7 Summary: Wireless Association List

LABEL	DESCRIPTION
#	This is the index number of an associated wireless station.
MAC Address	This field displays the MAC address of an associated wireless station.
Association Time	This field displays the time a wireless station first associated with the NBG-416N's WLAN network.
Refresh	Click Refresh to reload the list.

Connection Wizard

4.1 Wizard Setup

This chapter provides information on the wizard setup screens in the Web Configurator.

The Web Configurator's wizard setup helps you configure your device to access the Internet. Refer to your ISP (Internet Service Provider) checklist in the Quick Start Guide to know what to enter in each field. Leave a field blank if you don't have that information.

- 1 After you access the NBG-416N Web Configurator, click **Go to Wizard setup**.
You can click **Go to Advanced setup** to skip this wizard setup and configure basic or advanced features accordingly.

Figure 10 Select Wizard or Advanced Mode



- 2 Choose a language by clicking on the language's button. The screen will update. Click the **Next** button to proceed to the next screen.

Figure 11 Select a Language



- 3 Read the on-screen information and click **Next**.

Figure 12 Welcome to the Connection Wizard

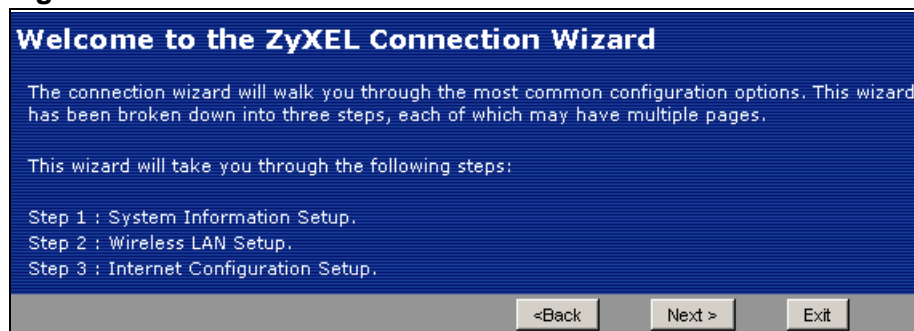

4.2 Connection Wizard: STEP 1: System Information

System Information contains administrative and system-related information.

4.2.1 System Name

System Name is for identification purposes. However, because some ISPs check this name you should enter your computer's "Computer Name".

- In Windows 95/98 click **Start > Settings > Control Panel > Network**. Click the Identification tab, note the entry for the **Computer Name** field and enter it as the **System Name**.
- In Windows 2000, click **Start > Settings** and **Control Panel** and then double-click **System**. Click the **Network Identification** tab and then the **Properties** button. Note the entry for the **Computer name** field and enter it as the **System Name**.
- In Windows XP, click **Start > My Computer > View system information** and then click the **Computer Name** tab. Note the entry in the **Full computer name** field and enter it as the NBG-416N **System Name**.

4.2.2 Domain Name

The **Domain Name** entry is what is propagated to the DHCP clients on the LAN. If you leave this blank, the domain name obtained by DHCP from the ISP is used. While you must enter the host name (System Name) on each individual computer, the domain name can be assigned from the NBG-416N via DHCP.

Click **Next** to configure the NBG-416N for Internet access.

Figure 13 Wizard Step 1: System Information

The following table describes the labels in this screen.

Table 8 Wizard Step 1: System Information

LABEL	DESCRIPTION
System Name	System Name is a unique name to identify the NBG-416N in an Ethernet network. Enter a descriptive name. This name can be up to 30 alphanumeric characters long. Spaces are not allowed, but dashes "-" and underscores "_" are accepted.
Domain Name	Type the domain name (if you know it) here. If you leave this field blank, the ISP may assign a domain name via DHCP. The domain name entered by you is given priority over the ISP assigned domain name.
Back	Click Back to display the previous screen.
Next	Click Next to proceed to the next screen.
Exit	Click Exit to close the wizard screen without saving.

4.3 Connection Wizard: STEP 2: Wireless LAN

Set up your wireless LAN using the following screen.

Figure 14 Wizard Step 2: Wireless LAN

The following table describes the labels in this screen.

Table 9 Wizard Step 2: Wireless LAN

LABEL	DESCRIPTION
Name (SSID)	Enter a descriptive name (up to 32 printable 7-bit ASCII characters) for the wireless LAN. If you change this field on the NBG-416N, make sure all wireless stations use the same SSID in order to access the network.
Security	Select a Security level from the drop-down list box. Choose Auto (WPA2-PSK) to have the NBG-416N generate a pre-shared key automatically. After you click Next a screen pops up displaying the generated pre-shared key. Write down the key for use later when connecting other wireless devices to your network. Click OK to continue. Choose None to have no wireless LAN security configured. If you do not enable any wireless security on your NBG-416N, your network is accessible to any wireless networking device that is within range. If you choose this option, skip directly to Section 4.4 on page 39 . Choose Extend (WPA-PSK or WPA2-PSK) security to configure a Pre-Shared Key. Choose this option only if your wireless clients support WPA-PSK or WPA2-PSK respectively. If you choose this option, skip directly to Section 4.3.1 on page 39 .
Channel Selection	The range of radio frequencies used by IEEE 802.11b/g/n wireless devices is called a channel. The device will automatically select the channel with the least interference.
Back	Click Back to display the previous screen.
Next	Click Next to proceed to the next screen.
Exit	Click Exit to close the wizard screen without saving.

Note: The wireless stations and NBG-416N must use the same SSID, channel ID, WPA-PSK (if WPA-PSK is enabled) or WPA2-PSK (if WPA2-PSK is enabled) for wireless communication.

4.3.1 Extend (WPA-PSK or WPA2-PSK) Security

Choose **Extend (WPA-PSK)** or **Extend (WPA2-PSK)** security in the Wireless LAN setup screen to set up a **Pre-Shared Key**.

Figure 15 Wizard Step 2: Extend (WPA-PSK or WPA2-PSK) Security

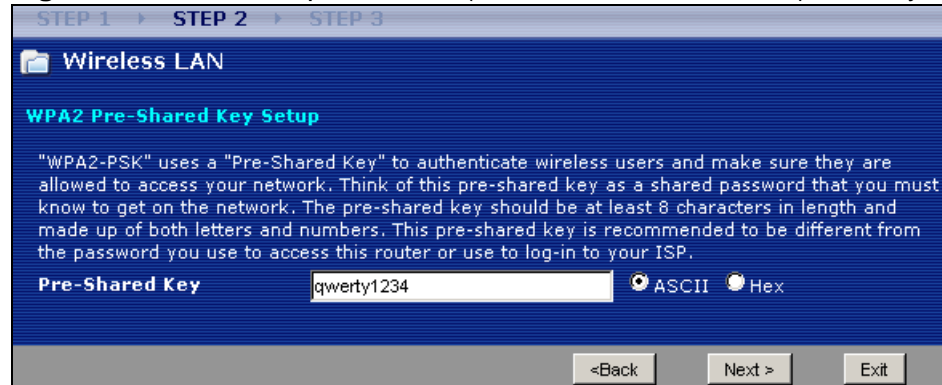

The following table describes the labels in this screen.

Table 10 Wizard Step 2: Extend (WPA-PSK or WPA2-PSK) Security

LABEL	DESCRIPTION
Pre-Shared Key	Type from 8 to 63 case-sensitive ASCII or HEX characters. You can set up the most secure wireless connection by configuring WPA in the wireless LAN screens. You need to configure an authentication server to do this.
Back	Click Back to display the previous screen.
Next	Click Next to proceed to the next screen.
Exit	Click Exit to close the wizard screen without saving.

4.4 Connection Wizard: STEP 3: Internet Configuration

The NBG-416N offers three Internet connection types. They are **Ethernet**, **PPP over Ethernet** or **PPTP**. The wizard attempts to detect which WAN connection type you are using. If the wizard does not detect a connection type, you must select one from the drop-down list box. Check with your ISP to make sure you use the correct type.

This wizard screen varies according to the connection type that you select.

Figure 16 Wizard Step 3: ISP Parameters.

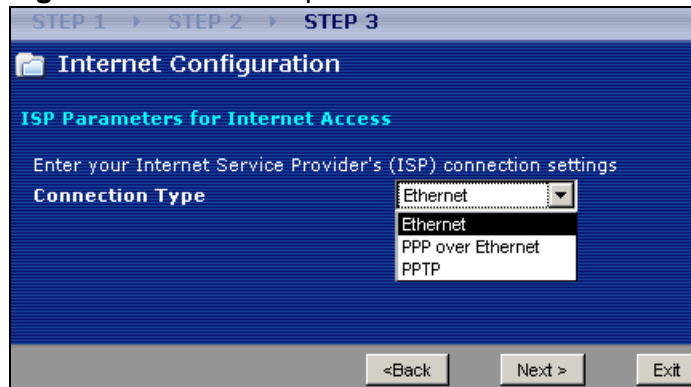

The following table describes the labels in this screen,

Table 11 Wizard Step 3: ISP Parameters

CONNECTION TYPE	DESCRIPTION
Ethernet	Select the Ethernet option when the WAN port is used as a regular Ethernet.
PPPoE	Select the PPP over Ethernet option for a dial-up connection. If your ISP gave you an IP address and/or subnet mask, then select PPTP .
PPTP	Select the PPTP option for a dial-up connection.

4.4.1 Ethernet Connection

Choose **Ethernet** when the WAN port is used as a regular Ethernet. Continue to [Section 4.4.4 on page 43](#).

Figure 17 Wizard Step 3: Ethernet Connection



4.4.2 PPPoE Connection

Point-to-Point Protocol over Ethernet (PPPoE) functions as a dial-up connection. PPPoE is an IETF (Internet Engineering Task Force) standard specifying how a host

personal computer interacts with a broadband modem (for example DSL, cable, wireless, etc.) to achieve access to high-speed data networks.

For the service provider, PPPoE offers an access and authentication method that works with existing access control systems (for instance, RADIUS).

One of the benefits of PPPoE is the ability to let end users access one of multiple network services, a function known as dynamic service selection. This enables the service provider to easily create and offer new IP services for specific users.

Operationally, PPPoE saves significant effort for both the subscriber and the ISP/ carrier, as it requires no specific configuration of the broadband modem at the subscriber's site.

By implementing PPPoE directly on the NBG-416N (rather than individual computers), the computers on the LAN do not need PPPoE software installed, since the NBG-416N does that part of the task. Furthermore, with NAT, all of the LAN's computers will have Internet access.

Figure 18 Wizard Step 3: PPPoE Connection

The screenshot shows a wizard window with a blue header and a grey footer. The header contains 'STEP 1 > STEP 2 > STEP 3' and 'Internet Configuration'. Below the header, the title 'ISP Parameters for Internet Access' is displayed in red. The main area contains the text 'Enter your Internet Service Provider's (ISP) connection settings'. There are four labeled input fields: 'Connection Type' (a dropdown menu showing 'PPP over Ethernet'), 'Service Name' (with '(optional)' to its right), 'User Name', and 'Password'. At the bottom, there are three buttons: '<Back', 'Next >', and 'Exit'.

The following table describes the labels in this screen.

Table 12 Wizard Step 3: PPPoE Connection

LABEL	DESCRIPTION
ISP Parameter for Internet Access	
Connection Type	Select the PPP over Ethernet option for a dial-up connection.
Service Name	Type the name of your service provider.
User Name	Type the user name given to you by your ISP.
Password	Type the password associated with the user name above.
Back	Click Back to return to the previous screen.
Next	Click Next to continue.
Exit	Click Exit to close the wizard screen without saving.

4.4.3 PPTP Connection

Point-to-Point Tunneling Protocol (PPTP) is a network protocol that enables transfers of data from a remote client to a private server, creating a Virtual Private Network (VPN) using TCP/IP-based networks.

PPTP supports on-demand, multi-protocol, and virtual private networking over public networks, such as the Internet.

Refer to the appendix for more information on PPTP.

Note: The NBG-416N supports one PPTP server connection at any given time.

Figure 19 Wizard Step 3: PPTP Connection

The following table describes the fields in this screen

Table 13 Wizard Step 3: PPTP Connection

LABEL	DESCRIPTION
ISP Parameters for Internet Access	
Connection Type	Select PPTP from the drop-down list box. To configure a PPTP client, you must configure the User Name and Password fields for a PPP connection and the PPTP parameters for a PPTP connection.
User Name	Type the user name given to you by your ISP.
Password	Type the password associated with the User Name above.
PPTP Configuration	
Server IP Address	Type the IP address of the PPTP server.

Table 13 Wizard Step 3: PPTP Connection (continued)

LABEL	DESCRIPTION
Connection ID/ Name	Enter the connection ID or connection name in this field. It must follow the "c:id" and "n:name" format. For example, C:12 or N:My ISP. This field is optional and depends on the requirements of your ISP.
Get automatically from ISP	Select this radio button if your ISP did not assign you a fixed IP address.
Use fixed IP address	Select this radio button, provided by your ISP to give the NBG-416N a fixed, unique IP address.
My IP Address	Type the (static) IP address assigned to you by your ISP.
My IP Subnet Mask	Type the subnet mask assigned to you by your ISP (if given).
Back	Click Back to return to the previous screen.
Next	Click Next to continue.
Exit	Click Exit to close the wizard screen without saving.

4.4.4 Your IP Address

The following wizard screen allows you to assign a fixed IP address or give the NBG-416N an automatically assigned IP address depending on your ISP.

Figure 20 Wizard Step 3: Your IP Address

The following table describes the labels in this screen

Table 14 Wizard Step 3: Your IP Address

LABEL	DESCRIPTION
Get automatically from your ISP	Select this option if your ISP did not assign you a fixed IP address. This is the default selection. If you choose this option, skip directly to Section 4.4.9 on page 47 .
Use fixed IP address provided by your ISP	Select this option if you were given IP address and/or DNS server settings by the ISP. The fixed IP address should be in the same subnet as your broadband modem or router.
Back	Click Back to return to the previous screen.
Next	Click Next to continue.
Exit	Click Exit to close the wizard screen without saving.

4.4.5 WAN IP Address Assignment

Every computer on the Internet must have a unique IP address. If your networks are isolated from the Internet, for instance, only between your two branch offices, you can assign any IP addresses to the hosts without problems. However, the Internet Assigned Numbers Authority (IANA) has reserved the following three blocks of IP addresses specifically for private networks.

Table 15 Private IP Address Ranges

10.0.0.0	-	10.255.255.255
172.16.0.0	-	172.31.255.255
192.168.0.0	-	192.168.255.255

You can obtain your IP address from the IANA, from an ISP or have it assigned by a private network. If you belong to a small organization and your Internet access is through an ISP, the ISP can provide you with the Internet addresses for your local networks. On the other hand, if you are part of a much larger organization, you should consult your network administrator for the appropriate IP addresses.

Note: Regardless of your particular situation, do not create an arbitrary IP address; always follow the guidelines above. For more information on address assignment, please refer to RFC 1597, Address Allocation for Private Internets and RFC 1466, Guidelines for Management of IP Address Space.

4.4.6 IP Address and Subnet Mask

Similar to the way houses on a street share a common street name, so too do computers on a LAN share one common network number.

Where you obtain your network number depends on your particular situation. If the ISP or your network administrator assigns you a block of registered IP addresses, follow their instructions in selecting the IP addresses and the subnet mask.

If the ISP did not explicitly give you an IP network number, then most likely you have a single user account and the ISP will assign you a dynamic IP address when the connection is established. The Internet Assigned Number Authority (IANA) reserved this block of addresses specifically for private use; please do not use any other number unless you are told otherwise. Let's say you select 192.168.1.0 as the network number; which covers 254 individual addresses, from 192.168.1.1 to 192.168.1.254 (zero and 255 are reserved). In other words, the first three numbers specify the network number while the last number identifies an individual computer on that network.

Once you have decided on the network number, pick an IP address that is easy to remember, for instance, 192.168.1.1, for your NBG-416N, but make sure that no other device on your network is using that IP address.

The subnet mask specifies the network number portion of an IP address. Your NBG-416N will compute the subnet mask automatically based on the IP address that you entered. You don't need to change the subnet mask computed by the NBG-416N unless you are instructed to do otherwise.

4.4.7 DNS Server Address Assignment

Use DNS (Domain Name System) to map a domain name to its corresponding IP address and vice versa, for instance, the IP address of www.zyxel.com is 204.217.0.2. The DNS server is extremely important because without it, you must know the IP address of a computer before you can access it.

The NBG-416N can get the DNS server addresses in the following ways.

- 1 The ISP tells you the DNS server addresses, usually in the form of an information sheet, when you sign up. If your ISP gives you DNS server addresses, enter them in the **DNS Server** fields in the **Wizard** and/or **WAN > Internet Connection** screen.
- 2 If the ISP did not give you DNS server information, leave the **DNS Server** fields set to **0.0.0.0** in the **Wizard** screen and/or set to **From ISP** in the **WAN > Internet Connection** screen for the ISP to dynamically assign the DNS server IP addresses.

4.4.8 WAN IP and DNS Server Address Assignment

The following wizard screen allows you to assign a fixed WAN IP address and DNS server addresses.

Figure 21 Wizard Step 3: WAN IP and DNS Server Addresses

The following table describes the labels in this screen

Table 16 Wizard Step 3: WAN IP and DNS Server Addresses

LABEL	DESCRIPTION
WAN IP Address Assignment	
My WAN IP Address	Enter your WAN IP address in this field. The WAN IP address should be in the same subnet as your DSL/Cable modem or router.
My WAN IP Subnet Mask	Enter the IP subnet mask in this field.
Gateway IP Address	Enter the gateway IP address in this field.
System DNS Server Address Assignment (if applicable)	
DNS (Domain Name System) is for mapping a domain name to its corresponding IP address and vice versa. The DNS server is extremely important because without it, you must know the IP address of a computer before you can access it. The NBG-416N uses a system DNS server (in the order you specify here) to resolve domain names for DDNS and the time server.	
First DNS Server	Enter the DNS server's IP address in the fields provided.
Second DNS Server	If you do not configure a system DNS server, you must use IP addresses when configuring DDNS and the time server.
Back	Click Back to return to the previous screen.
Next	Click Next to continue.
Exit	Click Exit to close the wizard screen without saving.

4.4.9 WAN MAC Address

Every Ethernet device has a unique MAC (Media Access Control) address. The MAC address is assigned at the factory and consists of six pairs of hexadecimal characters, for example, 00:A0:C5:00:00:02.

Table 17 Example of Network Properties for LAN Servers with Fixed IP Addresses

Choose an IP address	192.168.1.2-192.168.1.32; 192.168.1.65-192.168.1.254.
Subnet mask	255.255.255.0
Gateway (or default route)	192.168.1.1(NBG-416N LAN IP)

This screen allows users to configure the WAN port's MAC address by either using the NBG-416N's MAC address, copying the MAC address from a computer on your LAN or manually entering a MAC address. Once it is successfully configured, the address will be copied to configuration file. It is advisable to clone the MAC address from a computer on your LAN even if your ISP does not presently require MAC address authentication.

Figure 22 Wizard Step 3: WAN MAC Address

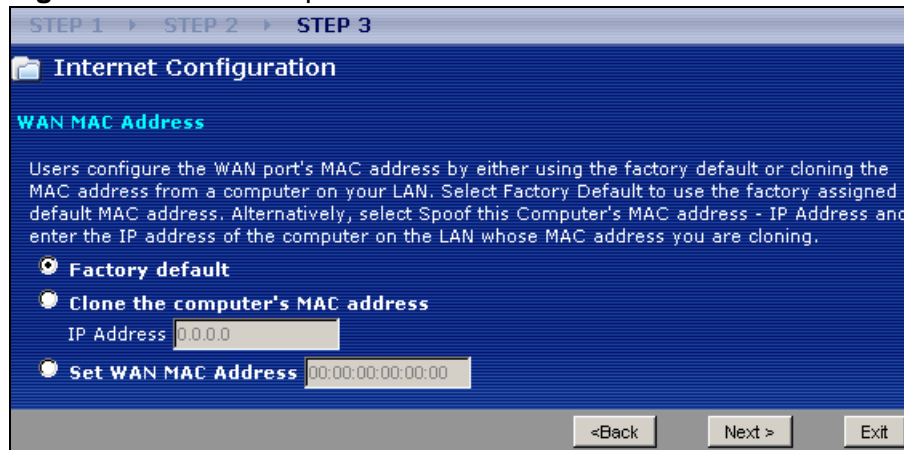

The following table describes the fields in this screen.

Table 18 Wizard Step 3: WAN MAC Address

LABEL	DESCRIPTION
Factory Default	Select Factory Default to use the factory assigned default MAC address.
Clone the computer's MAC address	Select this option and enter the IP address of the computer on the LAN whose MAC you are cloning. It is advisable to clone the MAC address from a computer on your LAN even if your ISP does not presently require MAC address authentication.
Set WAN MAC Address	Select this option and enter the MAC address you want to use.
Back	Click Back to return to the previous screen.
Next	Click Next to continue.
Exit	Click Exit to close the wizard screen without saving.

4.5 Connection Wizard Complete

Click **Finish** to complete the wizard setup.

Figure 23 Connection Wizard Complete

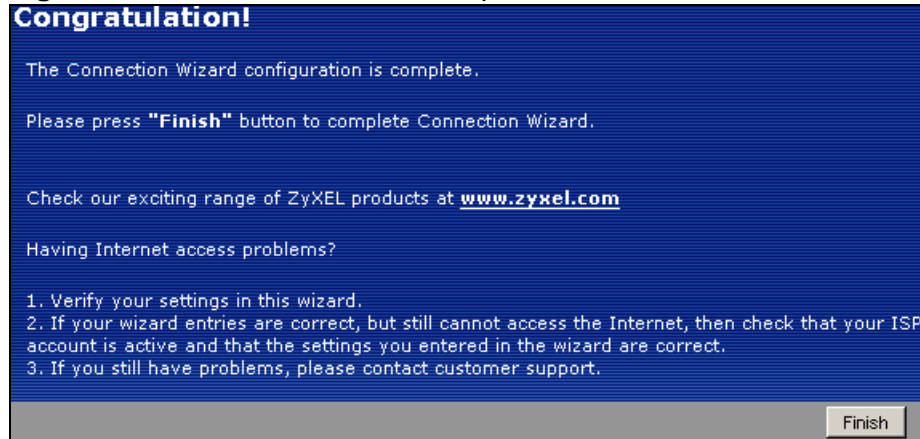

Well done! You have successfully set up your NBG-416N to operate on your network and access the Internet.

AP Mode

5.1 Overview

This chapter discusses how to configure settings while your NBG-416N is set to **AP Mode**. Many screens that are available in **Router Mode** are not available in **AP Mode**.

Note: See [Chapter 6 on page 57](#) for an example of setting up a wireless network in AP mode.

Use your NBG-416N as an AP if you already have a router or gateway on your network. In this mode your device bridges a wired network (LAN) and wireless LAN (WLAN) in the same subnet. See the figure below for an example.

Figure 24 Wireless Internet Access in AP Mode

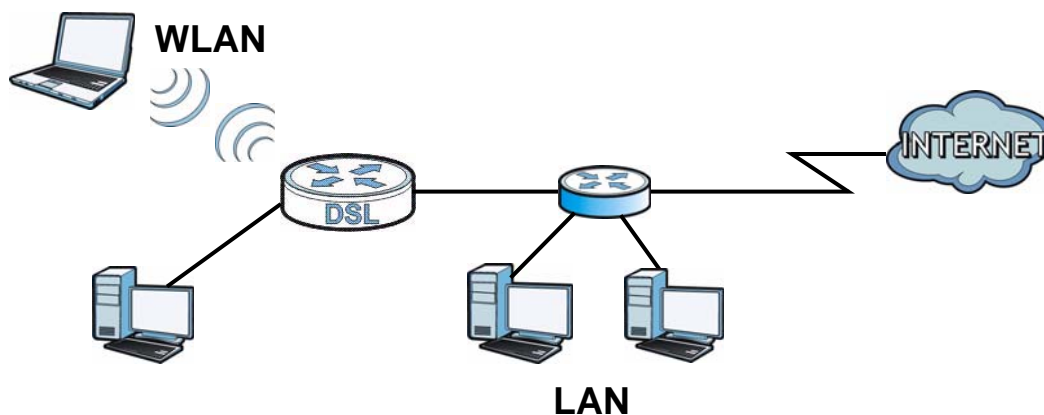

5.2 Setting your NBG-416N to AP Mode

- 1 Log into the Web Configurator if you haven't already. See the Quick start Guide for instructions on how to do this.

- To set your NBG-416N to **AP Mode**, go to **Maintenance > Sys OP Mode > General** and select **Access Point**.

Figure 25 Maintenance > Sys OP Mode > General

General

System Operation Mode

Router
 Access Point

Note :
Note : The IP address will not be bounded in the QoS limitation
Router: In this mode, the device is supported to connect to internet via ADSL/Cable Modem. PCs in LAN ports share the same IP to ISP through WAN Port.

- A pop-up appears providing information on this mode. Click **OK** in the pop-up message window. (See [Section 18.3 on page 140](#) for more information on the pop-up.) Click **Apply**. Your NBG-416N is now in **AP Mode**.

Note: You have to log in to the Web Configurator again when you change modes.

5.3 Status Screen (AP Mode)

Click on **Status**. The screen below shows the status screen in **AP Mode**.

Figure 26 Status Screen (AP Mode)

ZyXEL

Status

Refresh Interval: None Refresh Now

Device Information

System Name: NBG-416N
 Firmware Version: V1.00(USA.0)b1

LAN Information

- MAC Address: 00:01:02:CE:77:06
 - IP Address: 192.168.1.2
 - IP Subnet Mask: 255.255.255.0
 - DHCP: None

WLAN Information

- MAC Address: 00:01:02:CE:77:08
 - Status: On
 - Name(SSID): ZyXEL
 - Channel: Auto
 - Security Mode: OPEN
 - 802.11 Mode: 802.11 b/g/n
 - WPS: [Unconfigured](#)

System Status

System Up Time: 00:02:08
 Current Date/Time: 1970-01-01/00:02:08

System Resource:

- CPU Usage: 3%
 - Memory Usage: 47%

Interface Status

Interface	Status	Rate
LAN	Up	100M
WLAN	Up	150M

Summary

Packet Statistics ([Details...](#))
 WLAN Station Status ([Details...](#))

Message: Ready

The following table describes the labels shown in the **Status** screen.

Table 19 Status Screen (AP Mode)

LABEL	DESCRIPTION
Device Information	
System Name	This is the System Name you enter in the Maintenance > System > General screen. It is for identification purposes.
Firmware Version	This is the current firmware version of the NBG-416N.
LAN Information	
- MAC Address	This shows the LAN Ethernet adapter MAC Address of your device.
- IP Address	This shows the LAN port's IP address.
- IP Subnet Mask	This shows the LAN port's subnet mask.
- DHCP	This shows the LAN port's DHCP role - None .
WLAN Information	
- MAC Address	This shows the wireless adapter MAC Address of your device.
- Status	This shows the current status of the Wireless LAN - On , Off , or Off by scheduler .
- Name (SSID)	This shows a descriptive name used to identify the NBG-416N in the wireless LAN.
- Channel	This shows the channel number which you select manually.
- Security Mode	This shows the level of wireless security the NBG-416N is using.
- 802.11 Mode	This shows the IEEE 802.11 standard that the NBG-416N supports. Wireless clients must support the same standard in order to be able to connect to the NBG-416N
- WPS	This shows the WPS (WiFi Protected Setup) Status. Click the status to display Network > Wireless LAN > WPS screen.
System Status	
System Up Time	This is the total time the NBG-416N has been on.
Current Date/Time	This field displays your NBG-416N's present date and time.
System Resource	
- CPU Usage	This displays what percentage of the NBG-416N's processing ability is currently used. When this percentage is close to 100%, the NBG-416N is running at full load, and the throughput is not going to improve anymore. If you want some applications to have more throughput, you should turn off other applications.
- Memory Usage	This shows what percentage of the heap memory the NBG-416N is using.
Interface Status	
Interface	This displays the NBG-416N port types. The port types are: LAN and WLAN .
Status	For the LAN port, this field displays Down (line is down) or Up (line is up or connected). For the WLAN, it displays Up when the WLAN is enabled or Down when the WLAN is disabled.

Table 19 Status Screen (AP Mode) (continued)

LABEL	DESCRIPTION
Rate	For the LAN ports, this displays the port speed and duplex setting or N/A when the line is disconnected. For the WLAN, it displays the maximum transmission rate when the WLAN is enabled and N/A when the WLAN is disabled.
Summary	
Packet Statistics	Use this screen to view port status and packet specific statistics.
WLAN Station Status	Use this screen to view the wireless stations that are currently associated to the NBG-416N.

5.3.1 Navigation Panel

Use the menu in the navigation panel to configure NBG-416N features in **AP Mode**.

The following screen and table show the features you can configure in **AP Mode**.

Figure 27 Menu: AP Mode

The following table describes the sub-menus.

Table 20 Menu: AP Mode

LINK	TAB	FUNCTION
Status		This screen shows the NBG-416N's general device, system and interface status information. Use this screen to access the wizard, and summary statistics tables.
Network		

Table 20 Menu: AP Mode (continued)

LINK	TAB	FUNCTION
Wireless LAN	General	Use this screen to configure wireless LAN.
	MAC Filter	Use the MAC filter screen to configure the NBG-416N to block access to devices or block the devices from accessing the NBG-416N.
	Advanced	This screen allows you to configure advanced wireless settings.
	QoS	Use this screen to configure Wi-Fi Multimedia Quality of Service (WMM QoS). WMM QoS allows you to prioritize wireless traffic according to the delivery requirements of individual services.
	WPS	Use this screen to configure WPS.
	WPS Station	Use this screen to add a wireless station using WPS.
	Scheduling	Use this screen to schedule the times the Wireless LAN is enabled.
LAN	IP	Use this screen to configure LAN IP address and subnet mask.
Maintenance		
System	General	Use this screen to view and change administrative settings such as system and domain names, password and inactivity timer.
	Time Setting	Use this screen to change your NBG-416N's time and date.
Logs	View Log	Use this screen to view the logs for the categories that you selected.
Tools	Firmware	Use this screen to upload firmware to your NBG-416N.
	Configuration	Use this screen to backup and restore the configuration or reset the factory defaults to your NBG-416N.
	Restart	This screen allows you to reboot the NBG-416N without turning the power off.
Sys OP Mode	General	This screen allows you to select whether your device acts as a Router or a Access Point.
Language	Language	This screen allows you to select the language you prefer.

5.4 Configuring Your Settings

Use this section to configure your NBG-416N settings while in **AP Mode**.

5.4.1 LAN Settings

Click **Network > LAN** to see the screen below.

Note: If you change the IP address of the NBG-416N in the screen below, you will need to log into the NBG-416N again using the new IP address.

Figure 28 Network > LAN > IP

The screenshot shows a web interface for configuring the LAN TCP/IP settings. At the top, there is a navigation bar with 'IP' selected. Below it, the title 'LAN TCP/IP' is displayed. The main area contains two input fields: 'IP Address' with the value '192.168.1.1' and 'IP Subnet Mask' with the value '255.255.255.0'. At the bottom of the form, there are two buttons: 'Apply' and 'Reset'.

The table below describes the labels in the screen.

Table 21 Network > LAN > IP

LABEL	DESCRIPTION
Get from DHCP Server	Select this to let the DHCP server in the gateway assign the NBG-416N IP address.
User Defined LAN IP	Select this to give the NBG-416N a static IP address.
IP Address	Type the IP address in dotted decimal notation. The default setting is 192.168.1.2. If you change the IP address you will have to log in again with the new IP address.
IP Subnet Mask	The subnet mask specifies the network number portion of an IP address. Your NBG-416N will automatically calculate the subnet mask based on the IP address that you assign. Unless you are implementing subnetting, use the subnet mask computed by the NBG-416N.
Apply	Click Apply to save your changes to the NBG-416N.
Reset	Click Reset to reload the previous configuration for this screen.

5.4.2 WLAN and Maintenance Settings

The configuration of wireless and maintenance settings in **AP Mode** is the same as for **Router Mode**.

- See [Chapter 5 on page 69](#) for information on the configuring your wireless network.
- See [Troubleshooting \(145\)](#) for information on configuring your maintenance settings.

5.5 Logging in to the Web Configurator in AP Mode

- 1 Connect your computer to the LAN port of the NBG-416N.

- 2 The default IP address of the NBG-416N is "192.168.1.2". In this case, your computer must have an IP address in the range between "192.168.1.3" and "192.168.1.254".
- 3 Click **Start > Run** on your computer in Windows.
- 4 Type "cmd" in the dialog box.
- 5 Type "ipconfig" to show your computer's IP address. If your computer's IP address is not in the correct range then see [Appendix C on page 175](#) for information on changing your computer's IP address.
- 6 After you've set your computer's IP address, open a web browser such as Internet Explorer and type "192.168.1.2" as the web address in your web browser.

See [Chapter 6 on page 57](#) for a tutorial on setting up a network with an AP.

6.1 Overview

This chapter provides tutorials for your NBG-416N as follows:

- [How to Connect to the Internet from an AP](#)
 - [Configure Wireless Security Using WPS on both your NBG-416N and Wireless Client](#)
- [Enable and Configure Wireless Security without WPS on your NBG-416N](#)

6.2 How to Connect to the Internet from an AP

This section gives you an example of how to set up an access point (**AP**) and wireless client (a notebook, **B** in this example) for wireless communication. **B** can access the Internet through the AP wirelessly.

Figure 29 Wireless AP Connection to the Internet

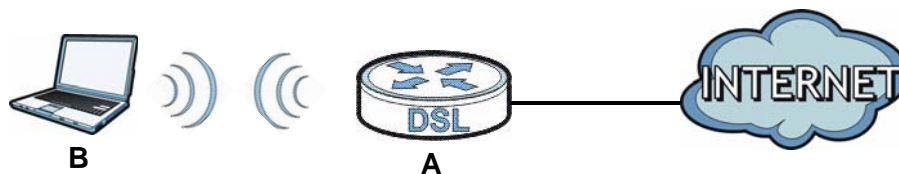

6.2.1 Configure Wireless Security Using WPS on both your NBG-416N and Wireless Client

This section gives you an example of how to set up wireless network using WPS. This example uses the NBG-416N as the AP and NWD210N as the wireless client which connects to a notebook.

Note: The wireless client must be a WPS-aware device (for example, a WPS USB adapter or PCI card).

There are two WPS methods for creating a secure connection. This tutorial shows you how to do both.

- **Push Button Configuration (PBC)** - create a secure wireless network simply by pressing a button. See [Section 6.2.1.1 on page 58](#). This is the easier method.
- **PIN Configuration** - create a secure wireless network simply by entering a wireless client's PIN (Personal Identification Number) in the NBG-416N's interface. See [Section 6.2.1.2 on page 59](#). This is the more secure method, since one device can authenticate the other.

6.2.1.1 Push Button Configuration (PBC)

- 1 Make sure that your NBG-416N is turned on and that it is within range of your computer.
- 2 Make sure that you have installed the wireless client (this example uses the NWD210N) driver and utility in your notebook.
- 3 In the wireless client utility, find the WPS settings. Enable WPS and press the WPS button (**Start** or **WPS** button)
- 4 Log into NBG-416N's Web Configurator and press **Push Button** in the **Network > Wireless Client > WPS Station** screen.

Note: Your NBG-416N has a WPS button located on its panel, as well as a WPS button in its configuration utility. Both buttons have exactly the same function; you can use one or the other.

Note: It doesn't matter which button is pressed first. You must press the second button within two minutes of pressing the first one.

The NBG-416N sends the proper configuration settings to the wireless client. This may take up to two minutes. Then the wireless client is able to communicate with the NBG-416N securely.

The following figure shows you an example to set up wireless network and security by pressing a button on both NBG-416N and wireless client (the NWD210N in this example).

Figure 30 Example WPS Process: PBC Method

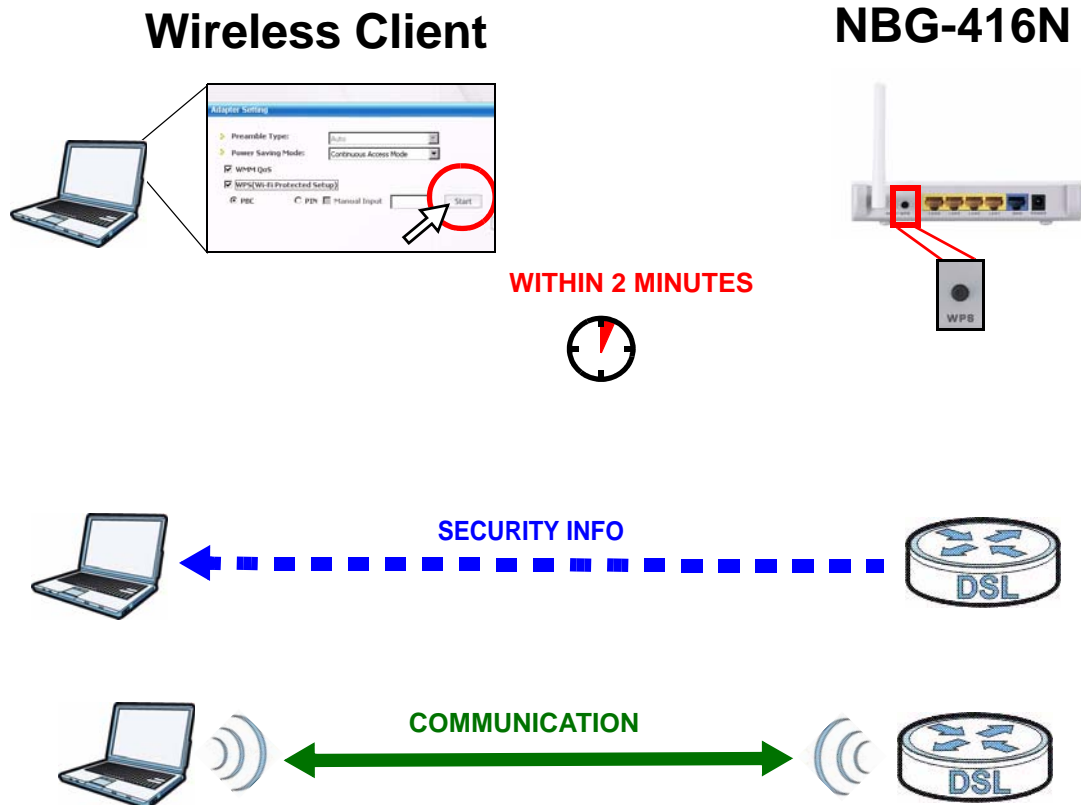

6.2.1.2 PIN Configuration

When you use the PIN configuration method, you need to use both NBG-416N's configuration interface and the client's utilities.

- 1 Launch your wireless client's configuration utility. Go to the WPS settings and select the PIN method to get a PIN number.
- 2 Enter the PIN number to the **PIN** field in the **Network > Wireless LAN > WPS Station** screen on the NBG-416N.
- 3 Click the **Start** buttons (or button next to the PIN field) on both the wireless client utility screen and the NBG-416N's **WPS Station** screen within two minutes.

The NBG-416N authenticates the wireless client and sends the proper configuration settings to the wireless client. This may take up to two minutes. Then the wireless client is able to communicate with the NBG-416N securely.

The following figure shows you the example to set up wireless network and security on NBG-416N and wireless client (ex. NWD210N in this example) by using PIN method.

Figure 31 Example WPS Process: PIN Method

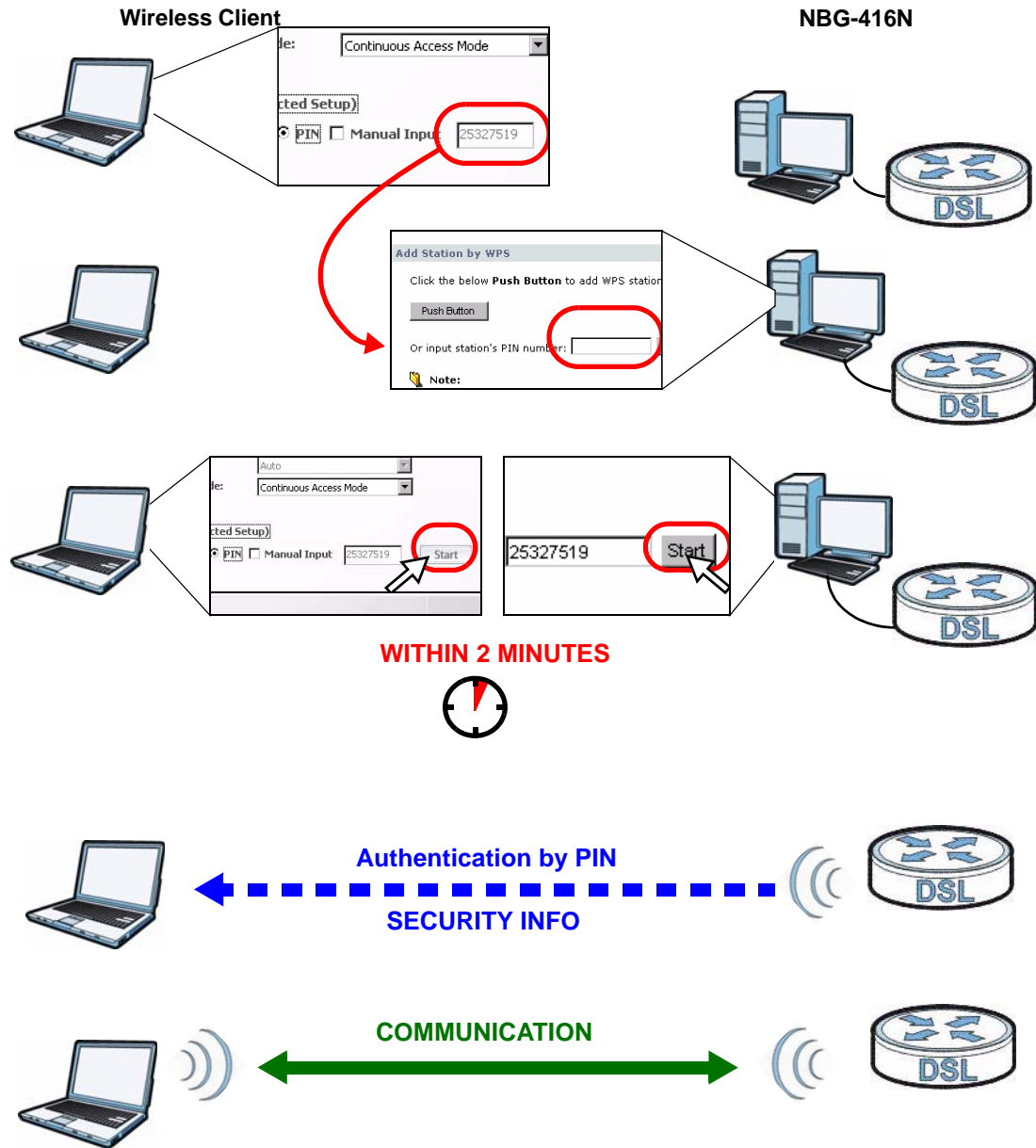

6.3 Enable and Configure Wireless Security without WPS on your NBG-416N

This example shows you how to configure wireless security settings with the following parameters on your NBG-416N.

SSID	SSID_Example3
Channel	6
Security	WPA-PSK (Pre-Shared Key: ThisismyWPA-PSKpre-sharedkey)

Follow the steps below to configure the wireless settings on your NBG-416N.

The instructions require that your hardware is connected (see the Quick Start Guide) and you are logged into the Web Configurator through your LAN connection (see [Section 3.2 on page 25](#)).

- 1 Open the **Wireless LAN > General** screen in the NBG-416N's Web Configurator.
- 2 Make sure the **Enable Wireless LAN** check box is selected.
- 3 Enter **SSID_Example3** as the SSID and select a channel.
- 4 Set security mode to **WPA-PSK** and enter **ThisismyWPA-PSKpre-sharedkey** in the **Pre-Shared Key** field. Click **Apply**.

Figure 32 Tutorial: Network > Wireless LAN > General

The screenshot displays the 'Wireless Setup' and 'Security' configuration pages. In the 'Wireless Setup' section, the 'Enable Wireless LAN' checkbox is checked. The 'Name(SSID)' field contains 'SSID_Example3'. The 'Channel Selection' is set to 'Channel-06 2437MHz'. In the 'Security' section, the 'Security Mode' is set to 'WPA-PSK' and the 'Pre-Shared Key' field contains 'ThisismyWPA-PSKpre-sharedkey'. The 'Group Key Update Timer' is set to '180 (In Seconds)'. A note at the bottom states: 'Note: WPA-PSK and WPA2-PSK can be configured when WPS enabled'. The 'Apply' button is highlighted.

- 5 Open the **Status** screen. Verify your wireless and wireless security settings under **Device Information** and check if the WLAN connection is up under **Interface Status**.

Figure 33 Tutorial: Status Screen

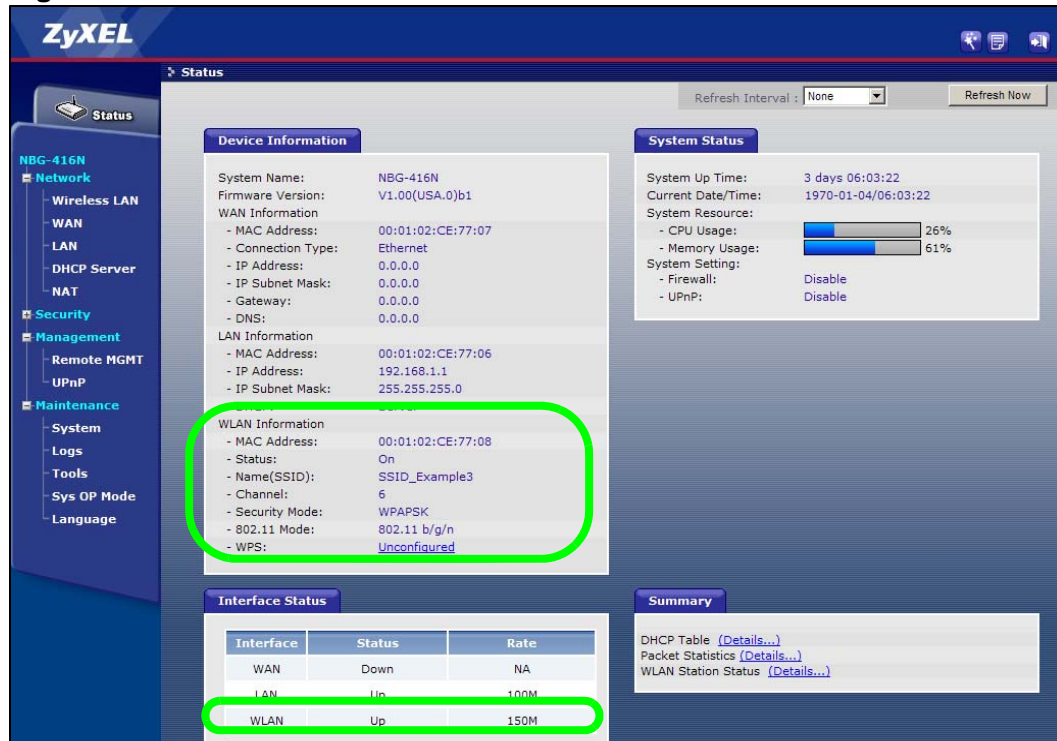

6.3.0.1 Configure Your Notebook

Note: We use the ZyXEL M-302 wireless adapter utility screens as an example for the wireless client. The screens may vary for different models.

- 1 The NBG-416N supports IEEE 802.11b, IEEE 802.11g and IEEE 802.11n wireless clients. Make sure that your notebook or computer's wireless adapter supports one of these standards.
- 2 Wireless adapters come with software sometimes called a "utility" that you install on your computer. See your wireless adapter's User's Guide for information on how to do that.
- 3 After you've installed the utility, open it. If you cannot see your utility's icon on your screen, go to **Start > Programs** and click on your utility in the list of programs that appears. The utility displays a list of APs within range, as shown in the example screen below.

- 4 Select **SSID_Example3** and click **Connect**.

Figure 34 Connecting a Wireless Client to a Wireless Network t

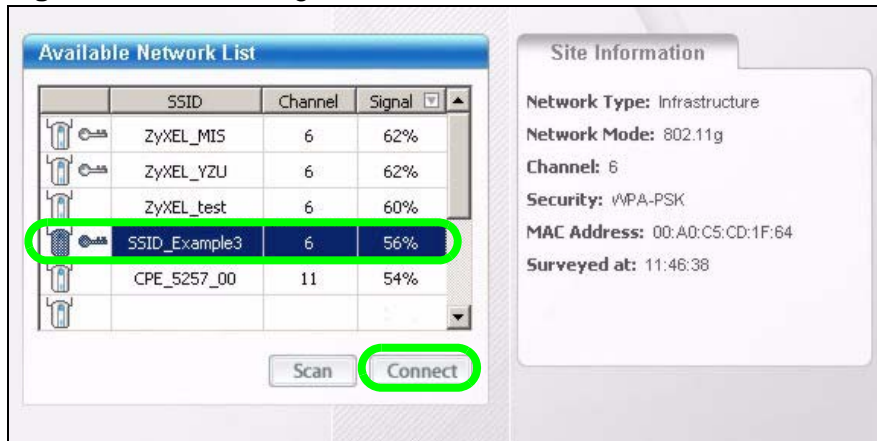

- 5 Select WPA-PSK and type the security key in the following screen. Click **Next**.

Figure 35 Security Settings

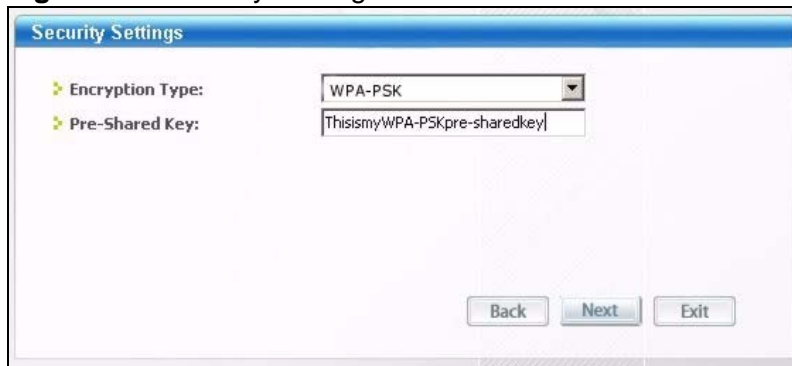

- 6 The **Confirm Save** window appears. Check your settings and click **Save** to continue.

Figure 36 Confirm Save

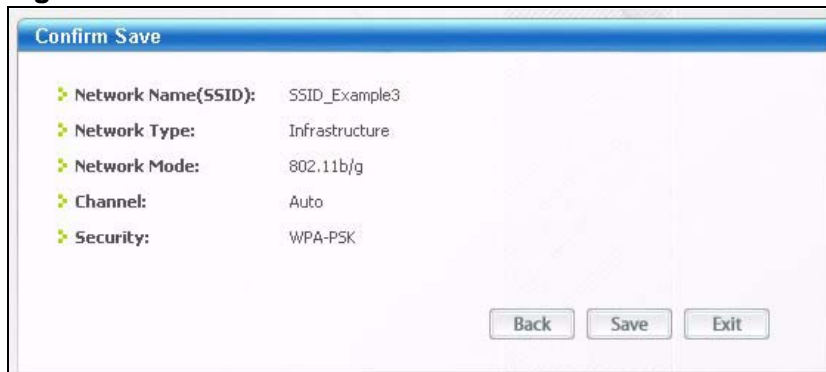

- 7 Check the status of your wireless connection in the screen below. If your wireless connection is weak or you have no connection, see the [Troubleshooting](#) section of this User's Guide.

Figure 37 Link Status

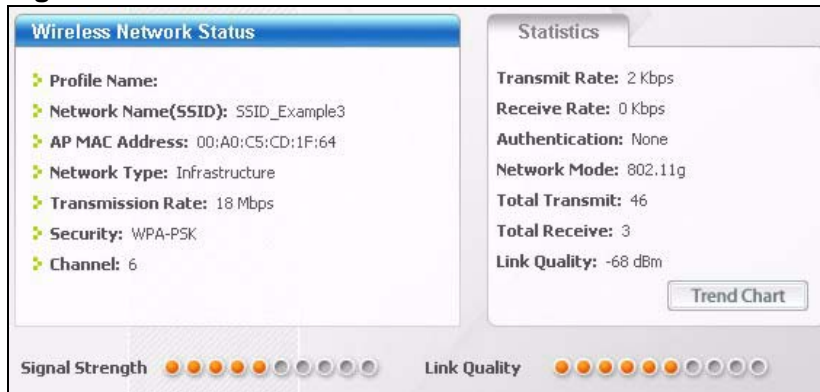

If your connection is successful, open your Internet browser and enter <http://www.zyxel.com> or the URL of any other web site in the address bar. If you are able to access the web site, your wireless connection is successfully configured.

PART II

Technical Reference

Wireless LAN

7.1 Overview

This chapter discusses how to configure the wireless network settings in your NBG-416N. See the appendices for more detailed information about wireless networks.

The following figure provides an example of a wireless network.

Figure 38 Example of a Wireless Network

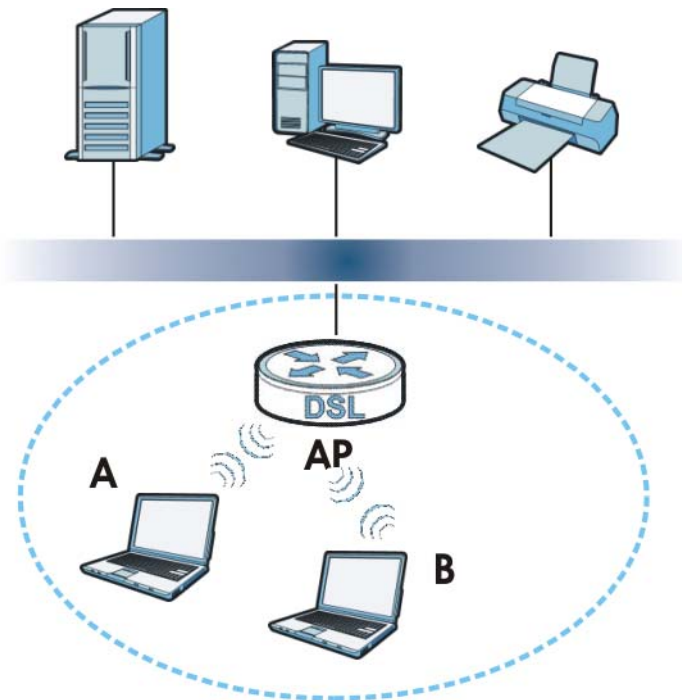

The wireless network is the part in the blue circle. In this wireless network, devices **A** and **B** are called wireless clients. The wireless clients use the access point (**AP**) to interact with other devices (such as the printer) or with the Internet. Your NBG-416N is the AP.

7.2 What You Can Do

- Use the **General** screen to enable the Wireless LAN, enter the SSID and select the wireless security mode ([Section 7.4 on page 71](#)).
- Use the **MAC Filter** screen to allow or deny wireless stations based on their MAC addresses from connecting to the NBG-416N ([Section 7.5 on page 76](#)).
- Use the **Advanced** screen to allow intra-BSS networking and set the RTS/CTS Threshold ([Section 7.6 on page 77](#)).
- Use the **QoS** screen to enable Wifi MultiMedia Quality of Service (WMMQoS). This allows the NBG-416N to automatically set priority levels to services, such as e-mail, VoIP, chat, and so on ([Section 7.7 on page 79](#)).
- Use the **WPS** screen to quickly set up a wireless network with strong security, without having to configure security settings manually ([Section 7.8 on page 80](#)).
- Use the **WPS Station** screen to add a wireless station using WPS ([Section 7.9 on page 81](#)).
- Use the **Scheduling** screen to set the times your wireless LAN is turned on and off ([Section 7.10 on page 81](#)).

7.3 What You Should Know

Every wireless network must follow these basic guidelines.

- Every wireless client in the same wireless network must use the same SSID.
The SSID is the name of the wireless network. It stands for Service Set IDentity.
- If two wireless networks overlap, they should use different channels.
Like radio stations or television channels, each wireless network uses a specific channel, or frequency, to send and receive information.
- Every wireless client in the same wireless network must use security compatible with the AP.

Security stops unauthorized devices from using the wireless network. It can also protect the information that is sent in the wireless network.

7.3.1 Wireless Security Overview

The following sections introduce different types of wireless security you can set up in the wireless network.

7.3.1.1 SSID

Normally, the AP acts like a beacon and regularly broadcasts the SSID in the area. You can hide the SSID instead, in which case the AP does not broadcast the SSID.

In addition, you should change the default SSID to something that is difficult to guess.

This type of security is fairly weak, however, because there are ways for unauthorized devices to get the SSID. In addition, unauthorized devices can still see the information that is sent in the wireless network.

7.3.1.2 MAC Address Filter

Every wireless client has a unique identification number, called a MAC address.¹ A MAC address is usually written using twelve hexadecimal characters²; for example, 00A0C5000002 or 00:A0:C5:00:00:02. To get the MAC address for each wireless client, see the appropriate User's Guide or other documentation.

You can use the MAC address filter to tell the AP which wireless clients are allowed or not allowed to use the wireless network. If a wireless client is allowed to use the wireless network, it still has to have the correct settings (SSID, channel, and security). If a wireless client is not allowed to use the wireless network, it does not matter if it has the correct settings.

This type of security does not protect the information that is sent in the wireless network. Furthermore, there are ways for unauthorized devices to get the MAC address of an authorized wireless client. Then, they can use that MAC address to use the wireless network.

7.3.1.3 User Authentication

You can make every user log in to the wireless network before they can use it. This is called user authentication. However, every wireless client in the wireless network has to support IEEE 802.1x to do this.

For wireless networks, there are two typical places to store the user names and passwords for each user.

- In the AP: this feature is called a local user database or a local database.
- In a RADIUS server: this is a server used in businesses more than in homes.

If your AP does not provide a local user database and if you do not have a RADIUS server, you cannot set up user names and passwords for your users.

Unauthorized devices can still see the information that is sent in the wireless network, even if they cannot use the wireless network. Furthermore, there are ways for unauthorized wireless users to get a valid user name and password. Then, they can use that user name and password to use the wireless network.

1. Some wireless devices, such as scanners, can detect wireless networks but cannot use wireless networks. These kinds of wireless devices might not have MAC addresses.

2. Hexadecimal characters are 0, 1, 2, 3, 4, 5, 6, 7, 8, 9, A, B, C, D, E, and F.

Local user databases also have an additional limitation that is explained in the next section.

7.3.1.4 Encryption

Wireless networks can use encryption to protect the information that is sent in the wireless network. Encryption is like a secret code. If you do not know the secret code, you cannot understand the message.

The types of encryption you can choose depend on the type of user authentication. (See [Section 7.3.1.3 on page 69](#) for information.)

Table 22 Types of Encryption for Each Type of Authentication

	NO AUTHENTICATION
Weakest	No Security
↑	Static WEP
↓	WPA-PSK
Strongest	WPA2-PSK

For example, if users do not log in to the wireless network, you can choose no encryption, **Static WEP**, **WPA-PSK**, or **WPA2-PSK**.

Usually, you should set up the strongest encryption that every wireless client in the wireless network supports. Suppose the wireless network has two wireless clients. Device A only supports WEP, and device B supports WEP and WPA. Therefore, you should set up **Static WEP** in the wireless network.

Note: It is recommended that wireless networks use WPA-PSK, WPA, or stronger encryption. IEEE 802.1x and WEP encryption are better than none at all, but it is still possible for unauthorized devices to figure out the original information pretty quickly.

Note: It is not possible to use WPA-PSK, WPA or stronger encryption with a local user database. In this case, it is better to set up stronger encryption with no authentication than to set up weaker encryption with the local user database.

When you select **WPA2** or **WPA2-PSK** in your NBG-416N, you can also select an option (**WPA Compatible**) to support WPA as well. In this case, if some wireless clients support WPA and some support WPA2, you should set up **WPA2-PSK** or **WPA2** (depending on the type of wireless network login) and select the **WPA Compatible** option in the NBG-416N.

Many types of encryption use a key to protect the information in the wireless network. The longer the key, the stronger the encryption. Every wireless client in the wireless network must have the same key.

7.3.1.5 WPS

WiFi Protected Setup (WPS) is an industry standard specification, defined by the WiFi Alliance. WPS allows you to quickly set up a wireless network with strong security, without having to configure security settings manually. Depending on the devices in your network, you can either press a button (on the device itself, or in its configuration utility) or enter a PIN (Personal Identification Number) in the devices. Then, they connect and set up a secure network by themselves. See how to set up a secure wireless network using WPS in the [Section 6.2.1 on page 57](#).

7.4 General Wireless LAN Screen

Use this screen to enable the Wireless LAN, enter the SSID and select the wireless security mode.

Note: If you are configuring the NBG-416N from a computer connected to the wireless LAN and you change the NBG-416N's SSID, channel or security settings, you will lose your wireless connection when you press **Apply** to confirm. You must then change the wireless settings of your computer to match the NBG-416N's new settings.

Click **Network > Wireless LAN** to open the **General** screen.

Figure 39 Network > Wireless LAN > General

The screenshot displays the configuration interface for the Wireless LAN. It features a series of tabs at the top: General (selected), MAC Filter, Advanced, QoS, WPS, WPS Station, and Scheduling. The main content area is divided into two sections: 'Wireless Setup' and 'Security'. In the 'Wireless Setup' section, the 'Enable Wireless LAN' checkbox is checked. The 'Name(SSID)' field contains 'ZyXEL'. The 'Hide SSID' checkbox is unchecked. The 'Channel Selection' dropdown is set to 'Channel-01 2412Mhz', and the 'Auto Channel Selection' checkbox is checked. The 'Operating Channel' dropdown is set to 'Channel- Auto', and the 'Channel Width' dropdown is set to 'Auto 20/40 MHz'. In the 'Security' section, the 'Security Mode' dropdown is set to 'No Security'. A yellow warning icon is followed by the text: 'Note: WPA-PSK and WPA2-PSK can be configured when WPS enabled'. At the bottom of the screen, there are 'Apply' and 'Reset' buttons.

The following table describes the general wireless LAN labels in this screen.

Table 23 Network > Wireless LAN > General

LABEL	DESCRIPTION
Enable Wireless LAN	Click the check box to activate wireless LAN.
Name(SSID)	(Service Set IDentity) The SSID identifies the Service Set with which a wireless station is associated. Wireless stations associating to the access point (AP) must have the same SSID. Enter a descriptive name (up to 32 printable 7-bit ASCII characters) for the wireless LAN.
Hide SSID	Select this check box to hide the SSID in the outgoing beacon frame so a station cannot obtain the SSID through scanning using a site survey tool.
Channel Selection	Set the operating frequency/channel depending on your particular region. Select a channel from the drop-down list box. The options vary depending on the frequency band and the country you are in. Refer to the Connection Wizard chapter for more information on channels. This option is only available if Auto Channel Selection is disabled.
Auto Channel Selection	Select this check box for the NBG-416N to automatically choose the channel with the least interference. Deselect this check box if you wish to manually select the channel using the Channel Section field.
Operating Channel	This displays the channel the NBG-416N is currently using.
Channel Width	Select whether the NBG-416N uses a wireless channel width of 20MHz or Auto 20/40MHz . A standard 20MHz channel offers transfer speeds of up to 150Mbps whereas a 40MHz channel uses two standard channels and offers speeds of up to 300 Mbps. Because not all devices support 40MHz channels, select Auto 20/40MHz to allow the NBG-416N to adjust the channel bandwidth automatically.
Security Mode	Select WPA-PSK or WPA2-PSK to add security on this wireless network. The wireless clients which want to associate to this network must have same wireless security settings as this device. After you select to use a security, additional options appears in this screen. See 7.4.2 and 7.4.3 sections. Or you can select No Security to allow any client to associate this network without authentication. Note: If you enable the WPS function, only No Security , WPA-PSK and WPA2-PSK are available in this field.
Apply	Click Apply to save your changes back to the NBG-416N.
Reset	Click Reset to reload the previous configuration for this screen.

See the rest of this chapter for information on the other labels in this screen.

7.4.1 No Security

Select **No Security** to allow wireless stations to communicate with the access points without any data encryption.

Note: If you do not enable any wireless security on your NBG-416N, your network is accessible to any wireless networking device that is within range.

Figure 40 Network > Wireless LAN > General: No Security



The following table describes the labels in this screen.

Table 24 Network > Wireless LAN > General: No Security

LABEL	DESCRIPTION
Security Mode	Choose No Security from the drop-down list box.
Apply	Click Apply to save your changes back to the NBG-416N.
Reset	Click Reset to reload the previous configuration for this screen.

7.4.2 WEP Encryption

WEP encryption scrambles the data transmitted between the wireless stations and the access points to keep network communications private. It encrypts unicast and multicast communications in a network. Both the wireless stations and the access points must use the same WEP key.

Your NBG-416N allows you to configure up to four 64-bit or 128-bit WEP keys but only one key can be enabled at any one time.

In order to configure and enable WEP encryption; click **Network > Wireless LAN** to display the **General** screen. Select **Static WEP** from the **Security Mode** list.

Figure 41 Network > Wireless LAN > General: Static WEP

The screenshot shows the 'Security' configuration window. At the top, 'Security Mode' is set to 'Static WEP', 'WEP Encryption' is '64-bit WEP', and 'Authentication Method' is 'Open System'. A yellow note icon is followed by text: 'Note: 64-bit WEP: Enter 5 ASCII characters or 10 hexadecimal characters ("0-9", "A-F") for each Key (1-4). 128-bit WEP: Enter 13 ASCII characters or 26 hexadecimal characters ("0-9", "A-F") for each Key (1-4). (Select one WEP key as an active key to encrypt wireless data transmission.)'. Below this, there are radio buttons for 'ASCII' (selected) and 'Hex'. Four radio buttons labeled 'Key 1' through 'Key 4' are positioned to the left of four empty text input fields. At the bottom, there is another yellow note icon with the text: 'Note: WPA-PSK and WPA2-PSK can be configured when WPS enabled'. At the very bottom, there are 'Apply' and 'Reset' buttons.

The following table describes the wireless LAN security labels in this screen.

Table 25 Network > Wireless LAN > General: Static WEP

LABEL	DESCRIPTION
Security Mode	Choose Static WEP from the drop-down list box.
WEP Encryption	Select 64-bit WEP or 128-bit WEP to enable data encryption.
Authentication Method	Select Auto , Open System or Shared Key from the drop-down list box. This field specifies whether the wireless clients have to provide the WEP key to login to the wireless client. Keep this setting at Auto or Open System unless you want to force a key verification before communication between the wireless client and the ZyXEL Device occurs. Select Shared Key to force the clients to provide the WEP key prior to communication.
ASCII	Select this option in order to enter ASCII characters as WEP key.
Hex	Select this option in order to enter hexadecimal characters as a WEP key. The preceding "0x", that identifies a hexadecimal key, is entered automatically.
Key 1 to Key 4	The WEP keys are used to encrypt data. Both the NBG-416N and the wireless stations must use the same WEP key for data transmission. If you chose 64-bit WEP , then enter any 5 ASCII characters or 10 hexadecimal characters ("0-9", "A-F"). If you chose 128-bit WEP , then enter 13 ASCII characters or 26 hexadecimal characters ("0-9", "A-F"). You must configure at least one key, only one key can be activated at any one time. The default key is key 1.

Table 25 Network > Wireless LAN > General: Static WEP (continued)

LABEL	DESCRIPTION
Apply	Click Apply to save your changes back to the NBG-416N.
Reset	Click Reset to reload the previous configuration for this screen.

7.4.3 WPA-PSK/WPA2-PSK

Click **Network > Wireless LAN** to display the **General** screen. Select **WPA-PSK** or **WPA2-PSK** from the **Security Mode** list.

Figure 42 Network > Wireless LAN > General: WPA-PSK/WPA2-PSK

The following table describes the labels in this screen.

Table 26 Network > Wireless LAN > General: WPA-PSK/WPA2-PSK

LABEL	DESCRIPTION
Security Mode	Choose WPA-PSK or WPA2-PSK from the drop-down list box.
WPA Compatible	This check box is available only when you select WPA2-PSK in the Security Mode field. Select the check box to have both WPA2 and WPA wireless clients be able to communicate with the NBG-416N even when the NBG-416N is using WPA2-PSK.
Pre-Shared Key	WPA-PSK/WPA2-PSK uses a simple common password for authentication. Type a pre-shared key from 8 to 63 case-sensitive ASCII characters (including spaces and symbols). Type a pre-shared key less than 64 case-sensitive HEX characters ("0-9", "A-F").
Group Key Update Timer	The Group Key Update Timer is the rate at which the AP (if using WPA-PSK/WPA2-PSK key management) or RADIUS server (if using WPA/WPA2 key management) sends a new group key out to all clients. The re-keying process is the WPA/WPA2 equivalent of automatically changing the WEP key for an AP and all stations in a WLAN on a periodic basis. Setting of the Group Key Update Timer is also supported in WPA-PSK/WPA2-PSK mode.
Apply	Click Apply to save your changes back to the NBG-416N.
Reset	Click Reset to reload the previous configuration for this screen.

7.5 MAC Filter

The MAC filter screen allows you to configure the NBG-416N to give exclusive access to up to 16 devices (Allow) or exclude up to 16 devices from accessing the NBG-416N (Deny). Every Ethernet device has a unique MAC (Media Access Control) address. The MAC address is assigned at the factory and consists of six pairs of hexadecimal characters, for example, 00:A0:C5:00:00:02. You need to know the MAC address of the devices to configure this screen.

To change your NBG-416N's MAC filter settings, click **Network > Wireless LAN > MAC Filter**. The screen appears as shown.

Figure 43 Network > Wireless LAN > MAC Filter

The following table describes the labels in this menu.

Table 27 Network > Wireless LAN > MAC Filter

LABEL	DESCRIPTION
Active	Select Yes from the drop down list box to enable MAC address filtering.
Filter Action	<p>Define the filter action for the list of MAC addresses in the MAC Address table.</p> <p>Select Deny to block access to the NBG-416N, MAC addresses not listed will be allowed to access the NBG-416N.</p> <p>Select Allow to permit access to the NBG-416N, MAC addresses not listed will be denied access to the NBG-416N.</p>

Table 27 Network > Wireless LAN > MAC Filter (continued)

LABEL	DESCRIPTION
Set	This is the index number of the MAC address.
MAC Address	Enter the MAC addresses of the wireless station that are allowed or denied access to the NBG-416N in these address fields. Enter the MAC addresses in a valid MAC address format, that is, six hexadecimal character pairs, for example, 12:34:56:78:9a:bc.
Apply	Click Apply to save your changes back to the NBG-416N.
Reset	Click Reset to reload the previous configuration for this screen.

7.6 Wireless LAN Advanced Screen

Use this screen to allow intra-BSS networking and set the RTS/CTS Threshold.

Click **Network > Wireless LAN > Advanced**. The screen appears as shown.

Figure 44 Network > Wireless LAN > Advanced

The screenshot shows the 'Advanced' tab of the Wireless LAN configuration interface. The 'Wireless Advanced Setup' section includes the following settings:

- 802.11 Mode: 802.11 b/g/n
- RTS/CTS Threshold: 2347 (range 0 ~ 2347)
- Fragment Threshold: 2346 (range 256 ~ 2346)
- Beacon Interval: 100 (range 20 ~ 1024 ms)
- DTIM Period: 1 (range 1 ~ 10)
- Preamble Type: Long Preamble, Short Preamble
- CTS Protection: Auto, None
- Tx Power: 100%
- Extension Channel (40Mhz only): None
- Aggregation: Enable, Disable
- Short GI: Enable, Disable
- Enable Intra-BSS Traffic: Enable, Disable

Buttons for 'Apply' and 'Reset' are located at the bottom of the configuration area.

The following table describes the labels in this screen.

Table 28 Network > Wireless LAN > Advanced

LABEL	DESCRIPTION
Wireless Advanced Setup	
RTS/CTS Threshold	Data with its frame size larger than this value will perform the RTS (Request To Send)/CTS (Clear To Send) handshake. Enter a value between 0 and 2347 .

Table 28 Network > Wireless LAN > Advanced (continued)

LABEL	DESCRIPTION
Fragmentation Threshold	<p>The threshold (number of bytes) for the fragmentation boundary for directed messages. It is the maximum data fragment size that can be sent. Enter an even number between 256 and 2346.</p> <p>This field is not available when Super Mode is selected.</p>
Beacon Interval	<p>When a wirelessly networked device sends a beacon, it includes with it a beacon interval. This specifies the time period before the device sends the beacon again. The interval tells receiving devices on the network how long they can wait in low-power mode before waking up to handle the beacon. This value can be set from 20 to 1024 ms. A high value helps save current consumption of the access point.</p>
DTIM Period	<p>Delivery Traffic Indication Message (DTIM) is the time period after which broadcast and multicast packets are transmitted to mobile clients in the Active Power Management mode. A high DTIM value can cause clients to lose connectivity with the network. This value can be set from 1 to 10.</p>
Preamble Type	<p>A preamble affects the timing in your wireless network. There are two preamble modes: long and short. If a device uses a different preamble mode than the NBG-416N does, it cannot communicate with the NBG-416N.</p>
CTS Protection	<p>When set to None, the NBG-416N protects wireless communication against interference.</p> <p>Select Auto to let the NBG-416N determine whether to turn this feature on or off in the current environment.</p>
Tx Power	<p>This field controls the transmission power of the NBG-416N. When using the NBG-416N with a notebook computer, select a lower transmission power level when you are close to the AP in order to conserve battery power.</p>
Extension Channel	<p>If you select Auto 20/40MHz as your Channel Bandwidth in the Wireless LAN > General screen, the extension channel enables the NBG-419N to get higher data throughput. This also lowers radio interference and traffic.</p>
Aggregation	<p>Select Enable to allow the grouping of several A-MSDUs (Aggregate MAC Service Data Units) into one large A-MPDU (Aggregate MAC Protocol Data Unit). This function allows faster data transfer rates.</p>
Short GI	<p>Select Enable to use Short GI (Guard Interval). The guard interval is the gap introduced between data transmission from users in order to reduce interference. Reducing the GI increases data transfer rates but also increases interference. Increasing the GI reduces data transfer rates but also reduces interference.</p>
Enable Intra-BSS Traffic	<p>A Basic Service Set (BSS) exists when all communications between wireless clients or between a wireless client and a wired network client go through one access point (AP).</p> <p>Intra-BSS traffic is traffic between wireless clients in the BSS. When Intra-BSS is enabled, wireless client A and B can access the wired network and communicate with each other. When Intra-BSS is disabled, wireless client A and B can still access the wired network but cannot communicate with each other.</p>
Apply	<p>Click Apply to save your changes to the NBG-416N.</p>
Reset	<p>Click Reset to reload the previous configuration for this screen.</p>

7.7 Quality of Service (QoS) Screen

Use the **QoS** screen to enable Wifi MultiMedia Quality of Service (WMMQoS). This allows the NBG-416N to automatically set priority levels to services, such as e-mail, VoIP, chat, and so on.

Click **Network > Wireless LAN > QoS**. The following screen appears.

Figure 45 Network > Wireless LAN > QoS



The following table describes the labels in this screen.

Table 29 Network > Wireless LAN > QoS

LABEL	DESCRIPTION
Enable WMM QoS	Check this to have the NBG-416N automatically give a service a priority level according to the ToS value in the IP header of packets it sends. WMM QoS (Wifi MultiMedia Quality of Service) gives high priority to voice and video, which makes them run more smoothly.
Apply	Click Apply to save your changes to the NBG-416N.
Reset	Click Reset to reload the previous configuration for this screen.

7.8 WPS Screen

Use this screen to enable/disable WPS, view or generate a new PIN number and check current WPS status. To open this screen, click **Network > Wireless LAN > WPS** tab.

Figure 46 Network > Wireless LAN > WPS

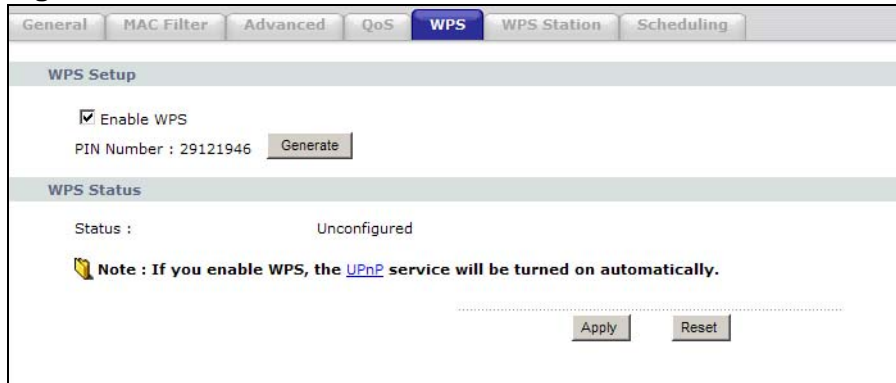

The following table describes the labels in this screen.

Table 30 Network > Wireless LAN > WPS

LABEL	DESCRIPTION
WPS Setup	
Enable WPS	Select this to enable the WPS feature.
PIN Number	This displays a PIN number last time system generated. Click Generate to generate a new PIN number.
WPS Status	
Status	This displays Configured when the NBG-416N has connected to a wireless network using WPS or when Enable WPS is selected and wireless or wireless security settings have been changed. The current wireless and wireless security settings also appear in the screen. This displays Unconfigured if WPS is disabled and there are no wireless or wireless security changes on the NBG-416N or you click Release_Configuration to remove the configured wireless and wireless security settings.
Release Configuration	This button is only available when the WPS status displays Configured . Click this button to remove all configured wireless and wireless security settings for WPS connections on the NBG-416N.
Apply	Click Apply to save your changes back to the NBG-416N.
Refresh	Click Refresh to get this screen information afresh.

7.9 WPS Station Screen

Use this screen when you want to add a wireless station using WPS. To open this screen, click **Network > Wireless LAN > WPS Station** tab.

Note: Note: After you click **Push Button** on this screen, you have to press a similar button in the wireless station utility within 2 minutes. To add the second wireless station, you have to press these buttons on both device and the wireless station again after the first 2 minutes.

Figure 47 Network > Wireless LAN > WPS Station

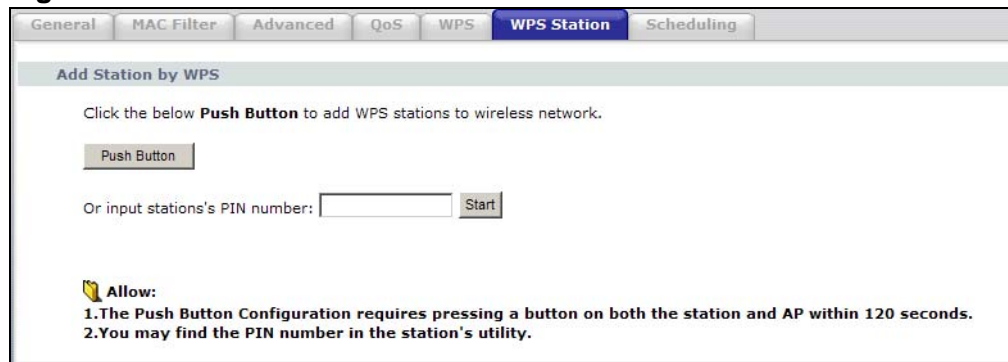

The following table describes the labels in this screen.

Table 31 Network > Wireless LAN > WPS Station

LABEL	DESCRIPTION
Push Button	Use this button when you use the PBC (Push Button Configuration) method to configure wireless stations's wireless settings. See Section 6.2.1.1 on page 58 . Click this to start WPS-aware wireless station scanning and the wireless security information synchronization.
Or input station's PIN number	Use this button when you use the PIN Configuration method to configure wireless station's wireless settings. See Section 6.2.1.2 on page 59 . Type the same PIN number generated in the wireless station's utility. Then click Start to associate to each other and perform the wireless security information synchronization.

7.10 Scheduling Screen

Use this screen to set the times your wireless LAN is turned on and off. Wireless LAN scheduling is disabled by default. The wireless LAN can be scheduled to turn

on or off on certain days and at certain times. To open this screen, click **Network** > **Wireless LAN** > **Scheduling** tab.

Figure 48 Network > Wireless LAN > Scheduling

The following table describes the labels in this screen.

Table 32 Network > Wireless LAN > Scheduling

LABEL	DESCRIPTION
Enable Wireless LAN Scheduling	Select this to enable Wireless LAN scheduling.
Action	Select On or Off to specify whether the Wireless LAN is turned on or off. This field works in conjunction with the Day and Except for the following times fields.
Day	Select Everyday or the specific days to turn the Wireless LAN on or off. If you select Everyday you can not select any specific days. This field works in conjunction with the Except for the following times field.
Except for the following times	Select a begin time using the first set of hour and minute (min) drop down boxes and select an end time using the second set of hour and minute (min) drop down boxes. If you have chosen On earlier for the WLAN Status the Wireless LAN will turn off between the two times you enter in these fields. If you have chosen Off earlier for the WLAN Status the Wireless LAN will turn on between the two times you enter in these fields. Note: Entering the same begin time and end time will mean the whole day.
Apply	Click Apply to save your changes back to the NBG-416N.
Reset	Click Reset to reload the previous configuration for this screen.

8.1 Overview

This chapter discusses the NBG-416N's **WAN** screens. Use these screens to configure your NBG-416N for Internet access.

A WAN (Wide Area Network) connection is an outside connection to another network or the Internet. It connects your private networks (such as a LAN (Local Area Network)) and other networks, so that a computer in one location can communicate with computers in other locations.

Figure 49 LAN and WAN

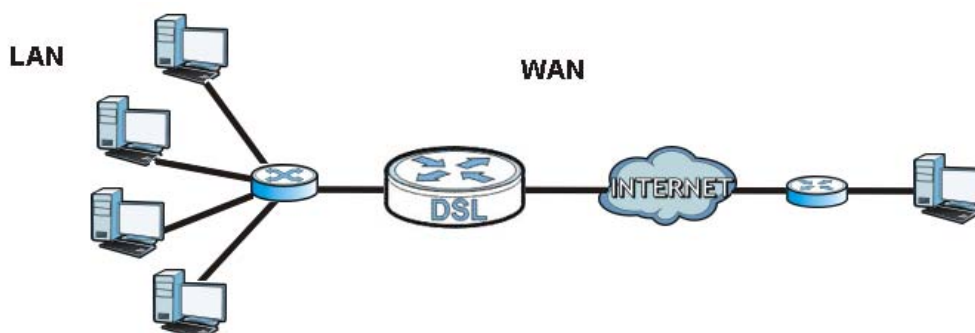

See the chapter about the connection wizard for more information on the fields in the WAN screens.

8.2 What You Need To Know

The information in this section can help you configure the screens for your WAN connection, as well as enable/disable some advanced features of your NBG-416N.

8.2.1 Configuring Your Internet Connection

Encapsulation Method

Encapsulation is used to include data from an upper layer protocol into a lower layer protocol. To set up a WAN connection to the Internet, you need to use the same encapsulation method used by your ISP (Internet Service Provider). If your ISP offers a dial-up Internet connection using PPPoE (PPP over Ethernet) or PPTP (Point-to-Point Tunneling Protocol), they should also provide a username and password (and service name) for user authentication.

WAN IP Address

The WAN IP address is an IP address for the NBG-416N, which makes it accessible from an outside network. It is used by the NBG-416N to communicate with other devices in other networks. It can be static (fixed) or dynamically assigned by the ISP each time the NBG-416N tries to access the Internet.

If your ISP assigns you a static WAN IP address, they should also assign you the subnet mask and DNS server IP address(es) (and a gateway IP address if you use the Ethernet or ENET ENCAP encapsulation method).

DNS Server Address Assignment

Use Domain Name System (DNS) to map a domain name to its corresponding IP address and vice versa, for instance, the IP address of `www.zyxel.com` is `204.217.0.2`. The DNS server is extremely important because without it, you must know the IP address of a computer before you can access it.

The NBG-416N can get the DNS server addresses in the following ways.

- 1 The ISP tells you the DNS server addresses, usually in the form of an information sheet, when you sign up. If your ISP gives you DNS server addresses, manually enter them in the DNS server fields.
- 2 If your ISP dynamically assigns the DNS server IP addresses (along with the NBG-416N's WAN IP address), set the DNS server fields to get the DNS server address from the ISP.

WAN MAC Address

The MAC address screen allows users to configure the WAN port's MAC address by either using the factory default or cloning the MAC address from a computer on your LAN. Choose **Factory Default** to select the factory assigned default MAC Address.

Otherwise, click **Clone the computer's MAC address - IP Address** and enter the IP address of the computer on the LAN whose MAC you are cloning. Once it is successfully configured, the address will be copied to configuration file. It is recommended that you clone the MAC address prior to hooking up the WAN Port.

8.3 Internet Connection

Use this screen to change your NBG-416N's Internet access settings. Click **Network > WAN**. The screen differs according to the encapsulation you choose.

8.3.1 Ethernet Encapsulation

This screen displays when you select **Ethernet** encapsulation.

Figure 50 Network > WAN > Internet Connection: Ethernet Encapsulation

The screenshot shows the 'Internet Connection' configuration page for Ethernet encapsulation. The page is divided into several sections:

- ISP Parameters for Internet Access:** The 'Connection Type' is set to 'Ethernet'.
- WAN IP Address Assignment:**
 - Get automatically from ISP
 - Use fixed IP Address
 - IP Address: 0.0.0.0
 - IP Subnet Mask: 255.255.255.0
 - Gateway IP Address: 0.0.0.0
 - MTU Auto: Auto
 - MTU: 1500 (576-1500)
- DNS Servers:**
 - First DNS Server: From ISP
 - Second DNS Server: (empty)
- WAN MAC Address:**
 - Factory default
 - Clone the computer's MAC address - MAC Address 00:24:21:7E:20:96
 - Set WAN MAC Address: 00:00:00:00:00:00

At the bottom of the page, there are 'Apply' and 'Reset' buttons.

The following table describes the labels in this screen.

Table 33 Network > WAN > Internet Connection: Ethernet Encapsulation

LABEL	DESCRIPTION
ISP Parameters for Internet Access	
Connection Type	You must choose the Ethernet option when the WAN port is used as a regular Ethernet.
WAN IP Address Assignment	
Get automatically from ISP	Select this option If your ISP did not assign you a fixed IP address. This is the default selection.
Use fixed IP Address	Select this option If the ISP assigned a fixed IP address.
IP Address	Enter your WAN IP address in this field if you selected Use Fixed IP Address .
IP Subnet Mask	Enter the IP Subnet Mask in this field.
Gateway IP Address	Enter a Gateway IP Address (if your ISP gave you one) in this field.
MTU Auto	Select Auto if you want to have the Maximum Transmission Unit (MTU) automatically configured. Select Manual if you want to have enter the MTU manually in the field below.
MTU	Enter the MTU or the largest packet size per frame that your NBG-416N can receive and process.
DNS Servers	
First DNS Server Second DNS Server	Select From ISP if your ISP dynamically assigns DNS server information (and the NBG-416N's WAN IP address). The field to the right displays the (read-only) DNS server IP address that the ISP assigns. Select User-Defined if you have the IP address of a DNS server. Enter the primary and secondary DNS server's IP address in the fields to the right.
WAN MAC Address	The MAC address section allows users to configure the WAN port's MAC address by either using the NBG-416N's MAC address, copying the MAC address from a computer on your LAN or manually entering a MAC address.
Factory default	Select Factory default to use the factory assigned default MAC Address.
Clone the computer's MAC address - IP Address	Select Clone the computer's MAC address - IP Address and enter the IP address of the computer on the LAN whose MAC you are cloning. Once it is successfully configured, the address will be copied to the rom file. It will not change unless you change the setting or upload a different ROM file.
Set WAN MAC Address	Select this option and enter the MAC address you want to use.
Apply	Click Apply to save your changes back to the NBG-416N.
Reset	Click Reset to begin configuring this screen afresh.

8.3.2 PPPoE Encapsulation

The NBG-416N supports PPPoE (Point-to-Point Protocol over Ethernet). PPPoE is an IETF standard (RFC 2516) specifying how a personal computer (PC) interacts with a broadband modem (DSL, cable, wireless, etc.) connection. The **PPP over Ethernet** option is for a dial-up connection using PPPoE.

For the service provider, PPPoE offers an access and authentication method that works with existing access control systems (for example Radius).

One of the benefits of PPPoE is the ability to let you access one of multiple network services, a function known as dynamic service selection. This enables the service provider to easily create and offer new IP services for individuals.

Operationally, PPPoE saves significant effort for both you and the ISP or carrier, as it requires no specific configuration of the broadband modem at the customer site.

By implementing PPPoE directly on the NBG-416N (rather than individual computers), the computers on the LAN do not need PPPoE software installed, since the NBG-416N does that part of the task. Furthermore, with NAT, all of the LANs' computers will have access.

This screen displays when you select **PPPoE** encapsulation.

Figure 51 Network > WAN > Internet Connection: PPPoE Encapsulation

The screenshot shows the 'Internet Connection' configuration page. The 'Connection Type' is set to 'PPP over Ethernet'. The 'Service Name' field is optional. The 'User Name', 'Password', and 'Retype to Confirm' fields are required. The 'MTU Size' is set to 1492, with a note '(512 <= MTU Value <= 1492)'. The 'Nailed-Up Connection' checkbox is checked. The 'Idle Timeout' is set to 5 minutes. The 'DNS Servers' section has two empty fields for 'First DNS Server' and 'Second DNS Server'. The 'WAN MAC Address' section has three radio button options: 'Factory default' (selected), 'Clone the computer's MAC address - MAC Address 00:24:21:7E:20:96', and 'Set WAN MAC Address' with a text input field containing '00:00:00:00:00:00'. At the bottom, there are 'Apply' and 'Reset' buttons.

The following table describes the labels in this screen.

Table 34 Network > WAN > Internet Connection: PPPoE Encapsulation

LABEL	DESCRIPTION
ISP Parameters for Internet Access	
Connection Type	Select PPP over Ethernet if you connect to your Internet via dial-up.
Service Name	Type the PPPoE service name provided to you. PPPoE uses a service name to identify and reach the PPPoE server.
User Name	Type the user name given to you by your ISP.
Password	Type the password associated with the user name above.
Retype to Confirm	Type your password again to make sure that you have entered is correctly.
MTU Size	Enter the MTU or the largest packet size per frame that your NBG-416N can receive and process.
Nailed-Up Connection	Select Nailed-Up Connection if you do not want the connection to time out.
Idle Timeout	This value specifies the time in minutes that elapses before the router automatically disconnects from the PPPoE server.
DNS Servers	
First DNS Server	Enter the primary and secondary DNS server's IP addresses.
Second DNS Server	If you do not configure a DNS server, you must know the IP address of a computer in order to access it.
WAN MAC Address	The MAC address section allows users to configure the WAN port's MAC address by using the NBG-416N's MAC address, copying the MAC address from a computer on your LAN or manually entering a MAC address.
Factory default	Select Factory default to use the factory assigned default MAC Address.
Clone the computer's MAC address - IP Address	Select Clone the computer's MAC address - IP Address and enter the IP address of the computer on the LAN whose MAC you are cloning. Once it is successfully configured, the address will be copied to the rom file. It will not change unless you change the setting or upload a different ROM file.
Set WAN MAC Address	Select this option and enter the MAC address you want to use.
Apply	Click Apply to save your changes back to the NBG-416N.
Reset	Click Reset to begin configuring this screen afresh.

8.3.3 PPTP Encapsulation

Point-to-Point Tunneling Protocol (PPTP) is a network protocol that enables secure transfer of data from a remote client to a private server, creating a Virtual Private Network (VPN) using TCP/IP-based networks.

PPTP supports on-demand, multi-protocol and virtual private networking over public networks, such as the Internet.

This screen displays when you select **PPTP** encapsulation.

Figure 52 Network > WAN > Internet Connection: PPTP Encapsulation

Internet Connection

ISP Parameters for Internet Access

Connection Type: PPTP

User Name:

Password:

Retype to Confirm:

MTU Size: 1460 (1200 <= MTU Value <= 1460)

Nailed-Up Connection

Idle Timeout: 5 (in minutes)

PPTP Configuration

Server IP Address: 10.0.0.254

Get automatically from ISP

Use fixed IP Address

My WAN IP Address: 192.168.0.100

My IP Subnet Mask: 255.255.255.0

My IP Gateway: 192.168.0.254

DNS Servers

First DNS Server:

Second DNS Server:

WAN MAC Address

Factory default

Clone the computer's MAC address - MAC Address 00:24:21:7E:20:96

Set WAN MAC Address:

Apply Reset

The following table describes the labels in this screen.

Table 35 Network > WAN > Internet Connection: PPTP Encapsulation

LABEL	DESCRIPTION
ISP Parameters for Internet Access	
Connection Type	Point-to-Point Tunneling Protocol (PPTP) is a network protocol that enables secure transfer of data from a remote client to a private server, creating a Virtual Private Network (VPN) using TCP/IP-based networks. PPTP supports on-demand, multi-protocol, and virtual private networking over public networks, such as the Internet. The NBG-416N supports only one PPTP server connection at any given time.
User Name	To configure a PPTP client, you must configure the User Name and Password fields for a PPP connection and the PPTP parameters for a PPTP connection. Type the user name given to you by your ISP.

Table 35 Network > WAN > Internet Connection: PPTP Encapsulation (continued)

LABEL	DESCRIPTION
Password	Type the password associated with the User Name above.
Retype to Confirm	Type your password again to make sure that you have entered correctly.
MTU Size	Enter the MTU or the largest packet size per frame that your NBG-416N can receive and process.
Nailed-up Connection	Select Nailed-Up Connection if you do not want the connection to time out.
Idle Timeout	This value specifies the time in minutes that elapses before the NBG-416N automatically disconnects from the PPTP server.
PPTP Configuration	
Server IP Address/ Domain	Type the IP address of the PPTP server.
Connection ID/ Name	Type your identification name for the PPTP server.
Get automatically from ISP	Select this option If your ISP did not assign you a fixed IP address. This is the default selection.
Use fixed IP Address	Select this option If the ISP assigned a fixed IP address.
My WAN IP Address	Enter your WAN IP address in this field if you selected Use Fixed IP Address .
My IP Subnet Mask	Your NBG-416N will automatically calculate the subnet mask based on the IP address that you assign. Unless you are implementing subnetting, use the subnet mask computed by the NBG-416N.
My IP Gateway	Enter a Gateway IP Address (if your ISP gave you one) in this field.
DNS Servers	
First DNS Server	Enter the primary and secondary DNS server's IP addresses.
Second DNS Server	If you do not configure a DNS server, you must know the IP address of a computer in order to access it.
WAN MAC Address	The MAC address section allows users to configure the WAN port's MAC address by either using the NBG-416N's MAC address, copying the MAC address from a computer on your LAN or manually entering a MAC address.
Factory default	Select Factory default to use the factory assigned default MAC Address.
Clone the computer's MAC address - IP Address	Select Clone the computer's MAC address - IP Address and enter the IP address of the computer on the LAN whose MAC you are cloning. Once it is successfully configured, the address will be copied to the rom file. It will not change unless you change the setting or upload a different ROM file.
Set WAN MAC Address	Select this option and enter the MAC address you want to use.
Apply	Click Apply to save your changes back to the NBG-416N.
Reset	Click Reset to begin configuring this screen afresh.

9.1 Overview

This chapter describes how to configure LAN settings.

A Local Area Network (LAN) is a shared communication system to which many computers are attached. A LAN is a computer network limited to the immediate area, usually the same building or floor of a building. The LAN screens can help you configure a LAN DHCP server, manage IP addresses, and partition your physical network into logical networks.

Figure 53 LAN Setup

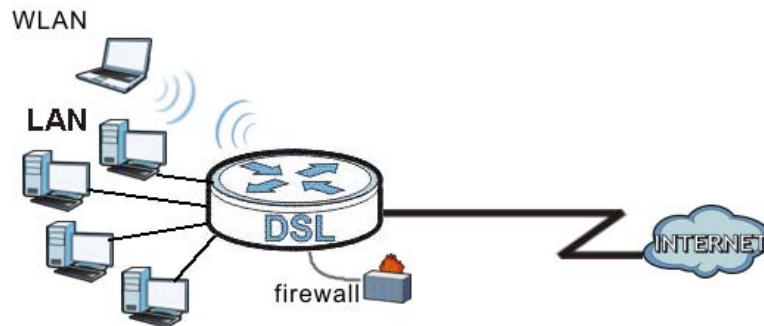

The LAN screens can help you configure a LAN DHCP server and manage IP addresses.

9.2 What You Need To Know

The actual physical connection determines whether the NBG-416N ports are LAN or WAN ports. There are two separate IP networks, one inside the LAN network and the other outside the WAN network as shown next.

Figure 54 LAN and WAN IP Addresses

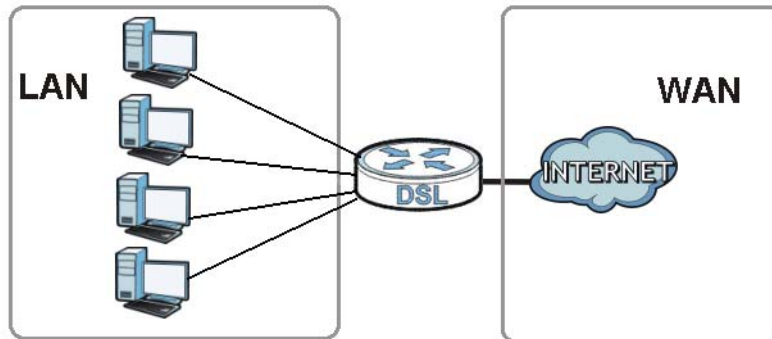

The LAN parameters of the NBG-416N are preset in the factory with the following values:

- IP address of 192.168.1.1 with subnet mask of 255.255.255.0 (24 bits)
- DHCP server enabled with 32 client IP addresses starting from 192.168.1.33.

These parameters should work for the majority of installations. If your ISP gives you explicit DNS server address(es), read the embedded Web Configurator help regarding what fields need to be configured.

9.2.1 IP Pool Setup

The NBG-416N is pre-configured with a pool of 32 IP addresses starting from 192.168.1.33 to 192.168.1.64. This configuration leaves 31 IP addresses (excluding the NBG-416N itself) in the lower range (192.168.1.2 to 192.168.1.32) for other server computers, for instance, servers for mail, FTP, TFTP, web, etc., that you may have.

Refer to [Section 4.4.6 on page 44](#) for information on IP Address and Subnet Mask.

9.2.2 LAN TCP/IP

The NBG-416N has built-in DHCP server capability that assigns IP addresses and DNS servers to systems that support DHCP client capability.

Refer to the [Section 4.4.7 on page 45](#) section for information on System DNS Servers.

9.3 LAN IP Screen

Use this screen to change your basic LAN settings. Click **Network** > **LAN**.

Figure 55 Network > LAN > IP

The following table describes the labels in this screen.

Table 36 Network > LAN > IP

LABEL	DESCRIPTION
IP Address	Type the IP address of your NBG-416N in dotted decimal notation 192.168.1.1 (factory default).
IP Subnet Mask	The subnet mask specifies the network number portion of an IP address. Your NBG-416N will automatically calculate the subnet mask based on the IP address that you assign. Unless you are implementing subnetting, use the subnet mask computed by the NBG-416N.
Apply	Click Apply to save your changes back to the NBG-416N.
Reset	Click Reset to begin configuring this screen afresh.

DHCP Server

10.1 Overview

DHCP (Dynamic Host Configuration Protocol, RFC 2131 and RFC 2132) allows individual clients to obtain TCP/IP configuration at start-up from a server. You can configure the NBG-416N's LAN as a DHCP server or disable it. When configured as a server, the NBG-416N provides the TCP/IP configuration for the clients. If DHCP service is disabled, you must have another DHCP server on your LAN, or else the computer must be manually configured.

10.2 What You Can Do

- Use the **General** screen to enable the DHCP server ([Section 10.4 on page 96](#)).
- Use the **Advanced** screen to assign IP addresses on the LAN to specific individual computers based on their MAC Addresses ([Section 10.5 on page 96](#)).
- Use the **Client List** screen to view the current DHCP client information ([Section 10.6 on page 98](#)).

10.3 What You Need To Know

Every Ethernet device has a unique MAC (Media Access Control) address. The MAC address is assigned at the factory and consists of six pairs of hexadecimal characters, for example, 00:A0:C5:00:00:02. Find out the MAC addresses of your network devices if you intend to add them to the DHCP Client List screen.

Refer to [Section 4.4.6 on page 44](#) for information on IP Address and Subnet Mask.

Refer to the [Section 4.4.7 on page 45](#) section for information on System DNS Servers.

10.4 General Screen

Use this screen to enable the DHCP server. Click **Network > DHCP Server**. The following screen displays.

Figure 56 Network > DHCP Server > General

The screenshot shows a web interface for DHCP configuration. At the top, there are three tabs: 'General' (selected), 'Advanced', and 'Client List'. Below the tabs is a section titled 'DHCP Setup'. Inside this section, there is a checkbox labeled 'Enable DHCP Server' which is checked. Below the checkbox are two input fields: 'IP Pool Starting Address' with the value '192.168.1.33' and 'Pool Size' with the value '32'. At the bottom of the form, there are two buttons: 'Apply' and 'Reset'.

The following table describes the labels in this screen.

Table 37 Network > DHCP Server > General

LABEL	DESCRIPTION
Enable DHCP Server	Enable or Disable DHCP for LAN. DHCP (Dynamic Host Configuration Protocol, RFC 2131 and RFC 2132) allows individual clients (computers) to obtain TCP/IP configuration at startup from a server. Leave the Enable DHCP Server check box selected unless your ISP instructs you to do otherwise. Clear it to disable the NBG-416N acting as a DHCP server. When configured as a server, the NBG-416N provides TCP/IP configuration for the clients. If not, DHCP service is disabled and you must have another DHCP server on your LAN, or else the computers must be manually configured. When set as a server, fill in the following four fields.
IP Pool Starting Address	This field specifies the first of the contiguous addresses in the IP address pool for LAN.
Pool Size	This field specifies the size, or count of the IP address pool for LAN.
Apply	Click Apply to save your changes back to the NBG-416N.
Reset	Click Reset to begin configuring this screen afresh.

10.5 Advanced Screen

This screen allows you to assign IP addresses on the LAN to specific individual computers based on their MAC addresses. You can also use this screen to configure the DNS server information that the NBG-416N sends to the DHCP clients.

To change your NBG-416N's static DHCP settings, click **Network > DHCP Server > Advanced**. The following screen displays.

Figure 57 Network > DHCP Server > Advanced

The following table describes the labels in this screen.

Table 38 Network > DHCP Server > Advanced

LABEL	DESCRIPTION
Static DHCP Table	
#	This is the index number of the static IP table entry (row).
MAC Address	Type the MAC address (with colons) of a computer on your LAN.
IP Address	Type the LAN IP address of a computer on your LAN.
DNS Server	
DNS Servers Assigned by DHCP Server	The NBG-416N passes a DNS (Domain Name System) server IP address (in the order you specify here) to the DHCP clients. If you do not configure the DNS server, the DHCP service is disabled and you must have another DHCP sever on your LAN, or else the computers must have their DNS server addresses manually configured.

Table 38 Network > DHCP Server > Advanced (continued)

LABEL	DESCRIPTION
First DNS Server Second DNS Server	<p>Select User-Defined if you have the IP address of a DNS server. Enter the DNS server's IP address in the field to the right. If you chose User-Defined, but leave the IP address set to 0.0.0.0, User-Defined changes to None after you click Apply. If you set a second choice to User-Defined, and enter the same IP address, the second User-Defined changes to None after you click Apply.</p> <p>Select DNS Relay to have the NBG-416N act as a DNS proxy. The NBG-416N's LAN IP address displays in the field to the right (read-only). The NBG-416N tells the DHCP clients on the LAN that the NBG-416N itself is the DNS server. When a computer on the LAN sends a DNS query to the NBG-416N, the NBG-416N forwards the query to the NBG-416N's system DNS server (configured in the WAN > Internet Connection screen) and relays the response back to the computer. You can only select DNS Relay for one of the three servers; if you select DNS Relay for a second or third DNS server, that choice changes to None after you click Apply.</p>
Apply	Click Apply to save your changes back to the NBG-416N.
Reset	Click Reset to begin configuring this screen afresh.

10.6 Client List Screen

The DHCP table shows current DHCP client information (including **IP Address**, **Host Name** and **MAC Address**) of network clients using the NBG-416N's DHCP servers.

Configure this screen to always assign an IP address to a MAC address (and host name). Click **Network > DHCP Server > Client List**.

Note: You can also view a read-only client list by clicking the **DHCP Table (Details...)** hyperlink in the **Status** screen.

The following screen displays.

Figure 58 Network > DHCP Server > Client List

#	IP Address	Host Name	MAC Address	Reserve
1	192.168.1.33	TWPC13262-01	00:1C:C4:84:E0:4B	<input type="checkbox"/>

The following table describes the labels in this screen.

Table 39 Network > DHCP Server > Client List

LABEL	DESCRIPTION
#	This is the index number of the host computer.
IP Address	This field displays the IP address relative to the # field listed above.
Host Name	This field displays the computer host name.
MAC Address	<p>The MAC (Media Access Control) or Ethernet address on a LAN (Local Area Network) is unique to your computer (six pairs of hexadecimal notation).</p> <p>A network interface card such as an Ethernet adapter has a hardwired address that is assigned at the factory. This address follows an industry standard that ensures no other adapter has a similar address.</p>
Reserve	Select this check box in the DHCP Setup section to have the NBG-416N always assign the IP address(es) to the MAC address(es) (and host name(s)). After you click Apply , the MAC address and IP address also display in the Advanced screen (where you can edit them).
Apply	Click Apply to save your settings.
Refresh	Click Refresh to reload the DHCP table.

Network Address Translation (NAT)

11.1 Overview

This chapter discusses how to configure NAT on the NBG-416N.

NAT (Network Address Translation - NAT, RFC 1631) is the translation of the IP address of a host in a packet. For example, the source address of an outgoing packet, used within one network is changed to a different IP address known within another network.

Each packet has two addresses – a source address and a destination address. For outgoing packets, NAT maps private (local) IP addresses to globally unique ones required for communication with hosts on other networks. It replaces the original IP source address in each packet and then forwards it to the Internet. The NBG-416N keeps track of the original addresses and port numbers so incoming reply packets can have their original values restored. The following figure illustrates this.

Figure 59 NAT Example

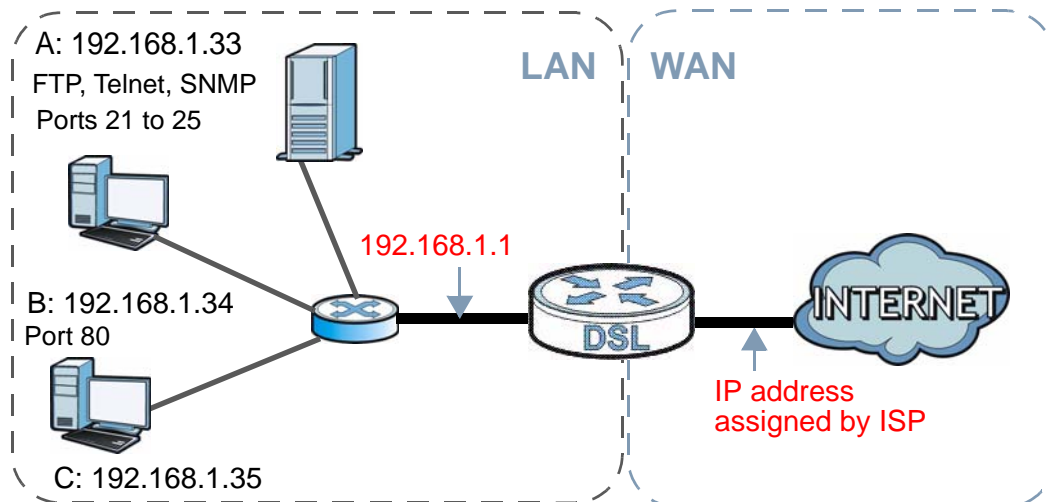

For more information on IP address translation, refer to *RFC 1631, The IP Network Address Translator (NAT)*.

Note: You must create a firewall rule in addition to setting up NAT, to allow traffic from the WAN to be forwarded through the NBG-416N.

11.2 What You Can Do

- Use the **General** screen to enable NAT and set a default server ([Section 11.3 on page 104](#)).
- Use the **Application** screen to change your NBG-416N's port forwarding settings ([Section 11.4 on page 105](#)).

11.2.1 What You Need To Know

The following terms and concepts may help as you read through this chapter.

Inside/Outside

This denotes where a host is located relative to the NBG-416N, for example, the computers of your subscribers are the inside hosts, while the web servers on the Internet are the outside hosts.

Global/Local

This denotes the IP address of a host in a packet as the packet traverses a router, for example, the local address refers to the IP address of a host when the packet is in the local network, while the global address refers to the IP address of the host when the same packet is traveling in the WAN side.

Note: Inside/outside refers to the location of a host, while global/local refers to the IP address of a host used in a packet.

An inside local address (ILA) is the IP address of an inside host in a packet when the packet is still in the local network, while an inside global address (IGA) is the IP address of the same inside host when the packet is on the WAN side. The following table summarizes this information.

Table 40 NAT Definitions

ITEM	DESCRIPTION
Inside	This refers to the host on the LAN.
Outside	This refers to the host on the WAN.

Table 40 NAT Definitions (continued)

ITEM	DESCRIPTION
Local	This refers to the packet address (source or destination) as the packet travels on the LAN.
Global	This refers to the packet address (source or destination) as the packet travels on the WAN.

Note: NAT never changes the IP address (either local or global) of an outside host.

What NAT Does

In the simplest form, NAT changes the source IP address in a packet received from a subscriber (the inside local address) to another (the inside global address) before forwarding the packet to the WAN side. When the response comes back, NAT translates the destination address (the inside global address) back to the inside local address before forwarding it to the original inside host. Note that the IP address (either local or global) of an outside host is never changed.

The global IP addresses for the inside hosts can be either static or dynamically assigned by the ISP. In addition, you can designate servers, for example, a web server and a telnet server, on your local network and make them accessible to the outside world. If you do not define any servers, NAT offers the additional benefit of firewall protection. With no servers defined, your NBG-416N filters out all incoming inquiries, thus preventing intruders from probing your network. For more information on IP address translation, refer to *RFC 1631, The IP Network Address Translator (NAT)*.

How NAT Works

Each packet has two addresses – a source address and a destination address. For outgoing packets, the ILA (Inside Local Address) is the source address on the LAN, and the IGA (Inside Global Address) is the source address on the WAN. For incoming packets, the ILA is the destination address on the LAN, and the IGA is the destination address on the WAN. NAT maps private (local) IP addresses to globally unique ones required for communication with hosts on other networks. It replaces the original IP source address in each packet and then forwards it to the Internet. The NBG-416N keeps track of the original addresses and port numbers

so incoming reply packets can have their original values restored. The following figure illustrates this.

Figure 60 How NAT Works

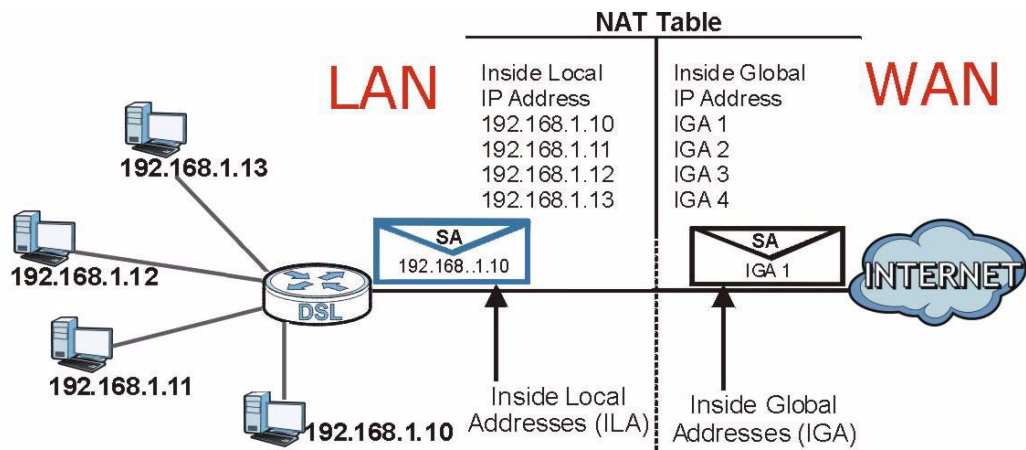

11.3 General NAT Screen

Use this screen to enable NAT and set a default server. Click **Network > NAT** to open the **General** screen.

Figure 61 Network > NAT > General

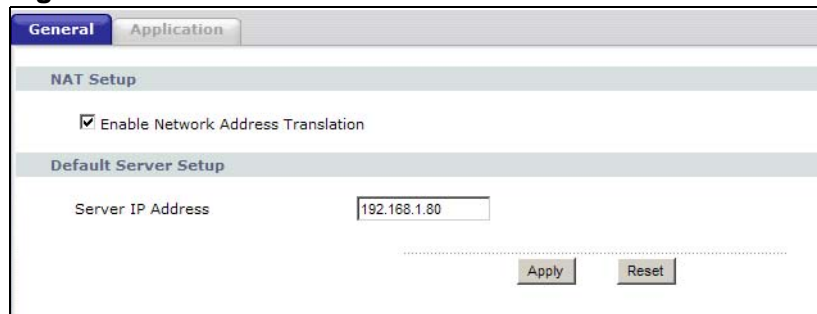

The following table describes the labels in this screen.

Table 41 Network > NAT > General

LABEL	DESCRIPTION
NAT Setup	
Enable Network Address Translation	Network Address Translation (NAT) allows the translation of an Internet protocol address used within one network (for example a private IP address used in a local network) to a different IP address known within another network (for example a public IP address used on the Internet). Select the check box to enable NAT.
Default Server Setup	

Table 41 Network > NAT > General (continued)

LABEL	DESCRIPTION
Server IP Address	<p>In addition to the servers for specified services, NAT supports a default server. A default server receives packets from ports that are not specified in the Application screen.</p> <p>If you do not assign a Default Server IP address, the NBG-416N discards all packets received for ports that are not specified in the Application screen or remote management.</p>
Apply	Click Apply to save your changes back to the NBG-416N.
Reset	Click Reset to begin configuring this screen afresh.

11.4 NAT Application Screen

Use the **Application** screen to forward incoming service requests to the server(s) on your local network. You may enter a single port number or a range of port numbers to be forwarded, and the local IP address of the desired server. The port number identifies a service; for example, web service is on port 80 and FTP on port 21. In some cases, such as for unknown services or where one server can support more than one service (for example both FTP and web service), it might be better to specify a range of port numbers.

In addition to the servers for specified services, NAT supports a default server. A service request that does not have a server explicitly designated for it is forwarded to the default server. If the default is not defined, the service request is simply discarded.

Note: Many residential broadband ISP accounts do not allow you to run any server processes (such as a Web or FTP server) from your location. Your ISP may periodically check for servers and may suspend your account if it discovers any active services at your location. If you are unsure, refer to your ISP.

Port forwarding allows you to define the local servers to which the incoming services will be forwarded. To change your NBG-416N's port forwarding settings, click **Network > NAT > Application**. The screen appears as shown.

Note: If you do not assign a **Default Server IP address** in the **NAT > General** screen, the NBG-416N discards all packets received for ports that are not specified in this screen or remote management.

Refer to [Appendix E on page 205](#) for port numbers commonly used for particular services.

Figure 62 Network > NAT > Application

The following table describes the labels in this screen.

Table 42 Network > NAT > Application

LABEL	DESCRIPTION
Add Application Rule	
Active	Select the check box to enable this rule and the requested service can be forwarded to the host with a specified internal IP address. Clear the checkbox to disallow forwarding of these ports to an inside server without having to delete the entry.
Service Name	Type a name (of up to 31 printable characters) to identify this rule in the first field next to Service Name . Otherwise, select a predefined service in the second field next to Service Name . The predefined service name and port number(s) will display in the Service Name and Port fields.
Local Port Range	Type a port number(s) to be forwarded.
Public Port Range	To specify a range of ports, enter a hyphen (-) between the first port and the last port, such as 10-20. To specify two or more non-consecutive port numbers, separate them by a comma without spaces, such as 123,567.
Server IP Address	Type the inside IP address of the server that receives packets from the port(s) specified in the Port field.
Apply	Click Apply to save your changes to the Application Rules Summary table.

Table 42 Network > NAT > Application (continued)

LABEL	DESCRIPTION
Reset	Click Reset to not save and return your new changes in the Service Name and Port fields to the previous one.
Application Rules Summary	
#	This is the number of an individual port forwarding server entry.
Active	This icon is turned on when the rule is enabled.
Name	This field displays a name to identify this rule.
Local Start/End Port	This field displays the port number(s).
Public Start/End Port	
Protocol	This field displays the traffic protocol type.
Server IP Address	This field displays the inside IP address of the server.
Modify	Click the Edit icon to display and modify an existing rule setting in the fields under Add Application Rule . Click the Remove icon to delete a rule.

11.5 Technical Reference

The following section contains additional technical information about the NBG-416N features described in this chapter.

11.5.1 NAT Port Forwarding: Services and Port Numbers

A port forwarding set is a list of inside (behind NAT on the LAN) servers, for example, web or FTP, that you can make accessible to the outside world even though NAT makes your whole inside network appear as a single machine to the outside world.

Use the **Application** screen to forward incoming service requests to the server(s) on your local network. You may enter a single port number or a range of port numbers to be forwarded, and the local IP address of the desired server. The port number identifies a service; for example, web service is on port 80 and FTP on port 21. In some cases, such as for unknown services or where one server can support more than one service (for example both FTP and web service), it might be better to specify a range of port numbers.

In addition to the servers for specified services, NAT supports a default server. A service request that does not have a server explicitly designated for it is forwarded

to the default server. If the default is not defined, the service request is simply discarded.

Note: Many residential broadband ISP accounts do not allow you to run any server processes (such as a Web or FTP server) from your location. Your ISP may periodically check for servers and may suspend your account if it discovers any active services at your location. If you are unsure, refer to your ISP.

11.5.2 NAT Port Forwarding Example

Let's say you want to assign ports 21-25 to one FTP, Telnet and SMTP server (**A** in the example), port 80 to another (**B** in the example) and assign a default server IP address of 192.168.1.35 to a third (**C** in the example). You assign the LAN IP addresses and the ISP assigns the WAN IP address. The NAT network appears as a single host on the Internet.

Figure 63 Multiple Servers Behind NAT Example

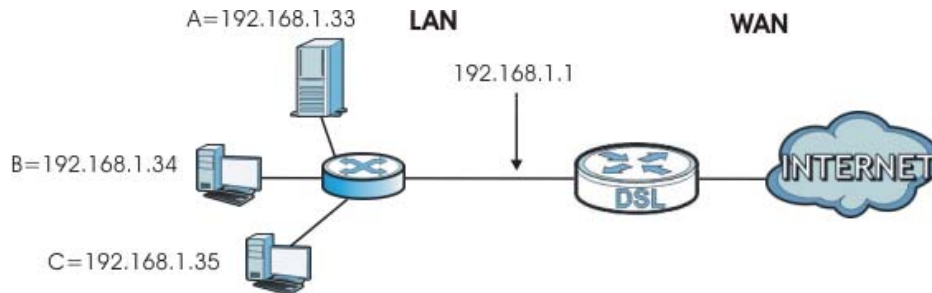

Firewall

12.1 Overview

Use these screens to enable and configure the firewall that protects your NBG-416N and your LAN from unwanted or malicious traffic.

Enable the firewall to protect your LAN computers from attacks by hackers on the Internet and control access between the LAN and WAN. By default the firewall:

- allows traffic that originates from your LAN computers to go to all of the networks.
- blocks traffic that originates on the other networks from going to the LAN.

The following figure illustrates the default firewall action. User **A** can initiate an IM (Instant Messaging) session from the LAN to the WAN (**1**). Return traffic for this session is also allowed (**2**). However other traffic initiated from the WAN is blocked (**3** and **4**).

Figure 64 Default Firewall Action

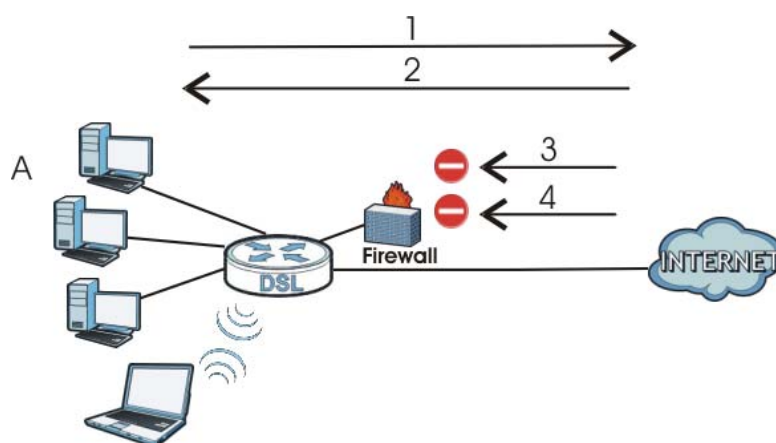

12.2 What You Can Do

- Use the **General** screen to enable or disable the NBG-416N's firewall ([Section 12.4 on page 111](#)).

- Use the **Services** screen to enable or disable ICMP and VPN passthrough features ([Section 12.5 on page 111](#)).

12.3 What You Need To Know

The NBG-416N's firewall feature physically separates the LAN and the WAN and acts as a secure gateway for all data passing between the networks.

12.3.1 About the NBG-416N Firewall

The NBG-416N firewall is a stateful inspection firewall and is designed to protect against Denial of Service attacks when activated (click the **General** tab under **Firewall** and then click the **Enable Firewall** check box). The NBG-416N's purpose is to allow a private Local Area Network (LAN) to be securely connected to the Internet. The NBG-416N can be used to prevent theft, destruction and modification of data, as well as log events, which may be important to the security of your network.

The NBG-416N is installed between the LAN and a broadband modem connecting to the Internet. This allows it to act as a secure gateway for all data passing between the Internet and the LAN.

The NBG-416N has one Ethernet WAN port and four Ethernet LAN ports, which are used to physically separate the network into two areas. The WAN (Wide Area Network) port attaches to the broadband (cable or DSL) modem to the Internet.

The LAN (Local Area Network) port attaches to a network of computers, which needs security from the outside world. These computers will have access to Internet services such as e-mail, FTP and the World Wide Web. However, "inbound access" is not allowed (by default) unless the remote host is authorized to use a specific service.

12.3.2 VPN Pass Through Features

A Virtual Private Network (VPN) is a way to securely connect two networks over the Internet. For example a home network and one in a business office. This requires special equipment on both ends of the connection.

The NBG-416N is not one of the endpoints but it does allow traffic from those endpoints to pass through. The NBG-416N allows the following types of VPN traffic to pass through:

- IP security (IPSec)
- Point-to-Point Tunneling Protocol (PPTP)

12.4 General Firewall Screen

Use this screen to enable or disable the NBG-416N's firewall, and set up firewall logs. Click **Security** > **Firewall** to open the **General** screen.

Figure 65 Security > Firewall > General

The following table describes the labels in this screen.

Table 43 Security > Firewall > General

LABEL	DESCRIPTION
Enable Firewall	Select this check box to activate the firewall. The NBG-416N performs access control and protects against Denial of Service (DoS) attacks when the firewall is activated.
Apply	Click Apply to save the settings.
Reset	Click Reset to start configuring this screen again.

12.5 Services Screen

Use the **Services** screen to enable or disable ICMP and VPN passthrough features.

Click **Security** > **Firewall** > **Services**. The screen appears as shown next.

Figure 66 Security > Firewall > Services

The following table describes the labels in this screen.

Table 44 Security > Firewall > Services

LABEL	DESCRIPTION
ICMP	Internet Control Message Protocol is a message control and error-reporting protocol between a host server and a gateway to the Internet. ICMP uses Internet Protocol (IP) datagrams, but the messages are processed by the TCP/IP software and directly apparent to the application user.
Respond to Ping on WAN	The NBG-416N will not respond to any incoming Ping requests when Disable is selected. Select Enable to reply to incoming WAN Ping requests.
VPN Passthrough	Select the checkbox to enable the advanced pass through features: <ul data-bbox="560 642 1425 814" style="list-style-type: none">• PPTP Passthrough: Select this option to allow the NBG-416N to pass through VPN traffic using PPTP.• L2TP Passthrough: Select this option to enable computers on your LAN to make L2TP VPN connections to servers on the Internet.• IPSEC Passthrough: Select this option to allow the NBG-416N to pass through VPN traffic using the IPsec protocol.
Apply	Click Apply to save the settings.
Reset	Click Reset to start configuring this screen again.

Remote Management

13.1 Overview

This chapter provides information on the **Remote Management** screens.

Remote management allows you to determine which services/protocols can access which NBG-416N interface (if any) from which computers.

You may manage your NBG-416N from a remote location via:

- LAN only
- LAN and WAN

Note: When you configure remote management to allow management from the LAN and WAN in the options above, you still need to configure a firewall rule to allow access. See the firewall chapters for details on configuring firewall rules.

13.2 What You Need To Know

13.2.1 Remote Management Limitations

Remote management over LAN or WAN will not work when:

- 1 You have disabled that service in one of the remote management screens.
- 2 The IP address in the **Secured Client IP Address** field does not match the client IP address. If it does not match, the NBG-416N will disconnect the session immediately.
- 3 There is already another remote management session with an equal or higher priority running. You may only have one remote management session running at one time.
- 4 There is a firewall rule that blocks it.

13.2.2 Remote Management and NAT

When NAT is enabled:

- Use the NBG-416N's WAN IP address when configuring from the WAN.
- Use the NBG-416N's LAN IP address when configuring from the LAN.

13.2.3 System Timeout

There is a default system management idle timeout of five minutes (three hundred seconds). The NBG-416N automatically logs you out if the management session remains idle for longer than this timeout period. The management session does not time out when a statistics screen is polling. You can change the timeout period in the **System** screen.

13.3 WWW Screen

To change your NBG-416N's World Wide Web settings, click **Management** > **Remote MGMT** to display the **WWW** screen.

Figure 67 Management > Remote MGMT > WWW

The following table describes the labels in this screen.

Table 45 Management > Remote MGMT > WWW

LABEL	DESCRIPTION
Server Port	You may change the server port number for a service if needed, however you must use the same port number in order to use that service for remote management.
Server Access	Select the interface(s) through which a computer may access the NBG-416N using this service.
Secured Client IP Address	A secured client is a "trusted" computer that is allowed to communicate with the NBG-416N using this service. Select All to allow any computer to access the NBG-416N using this service. Choose Selected to just allow the computer with the IP address that you specify to access the NBG-416N using this service. Note: This only applies on WAN IP.
Apply	Click Apply to save your customized settings and exit this screen.
Reset	Click Reset to begin configuring this screen afresh.

Universal Plug-and-Play (UPnP)

14.1 Overview

This chapter introduces the UPnP feature in the Web Configurator.

Universal Plug and Play (UPnP) is a distributed, open networking standard that uses TCP/IP for simple peer-to-peer network connectivity between devices. A UPnP device can dynamically join a network, obtain an IP address, convey its capabilities and learn about other devices on the network. In turn, a device can leave a network smoothly and automatically when it is no longer in use.

14.2 What You Need to Know

How do I know if I'm using UPnP?

UPnP hardware is identified as an icon in the Network Connections folder (Windows XP). Each UPnP compatible device installed on your network will appear as a separate icon. Selecting the icon of a UPnP device will allow you to access the information and properties of that device.

NAT Traversal

UPnP NAT traversal automates the process of allowing an application to operate through NAT. UPnP network devices can automatically configure network addressing, announce their presence in the network to other UPnP devices and enable exchange of simple product and service descriptions. NAT traversal allows the following:

- Dynamic port mapping
- Learning public IP addresses
- Assigning lease times to mappings

Windows Messenger is an example of an application that supports NAT traversal and UPnP.

See the NAT chapter for more information on NAT.

Cautions with UPnP

The automated nature of NAT traversal applications in establishing their own services and opening firewall ports may present network security issues. Network information and configuration may also be obtained and modified by users in some network environments.

When a UPnP device joins a network, it announces its presence with a multicast message. For security reasons, the NBG-416N allows multicast messages on the LAN only.

All UPnP-enabled devices may communicate freely with each other without additional configuration. Disable UPnP if this is not your intention.

14.3 UPnP Screen

Use this screen to enable UPnP. Click the **Management > UPnP** to open the following screen.

Figure 68 Management > UPnP > General



The following table describes the labels in this screen.

Table 46 Management > UPnP > General

LABEL	DESCRIPTION
Enable the Universal Plug and Play (UPnP) Feature	Select this check box to activate UPnP. Be aware that anyone could use a UPnP application to open the Web Configurator's login screen without entering the NBG-416N's IP address (although you must still enter the password to access the Web Configurator).
Allow users to make port forwarding changes through UPnP	Select this check box to allow UPnP-enabled applications to automatically configure the NBG-416N so that they can communicate through the NBG-416N, for example by using NAT traversal, UPnP applications automatically reserve a NAT forwarding port in order to communicate with another UPnP enabled device; this eliminates the need to manually configure port forwarding for the UPnP enabled application.
Apply	Click Apply to save the setting to the NBG-416N.
Reset	Click Reset to begin configuring this screen afresh.

14.4 Technical Reference

The sections show examples of using UPnP.

14.4.1 Using UPnP in Windows XP Example

This section shows you how to use the UPnP feature in Windows XP. You must already have UPnP installed in Windows XP and UPnP activated on the NBG-416N.

Make sure the computer is connected to a LAN port of the NBG-416N. Turn on your computer and the NBG-416N.

14.4.1.1 Auto-discover Your UPnP-enabled Network Device

- 1 Click **start** and **Control Panel**. Double-click **Network Connections**. An icon displays under Internet Gateway.

- 2 Right-click the icon and select **Properties**.

Figure 69 Network Connections



- 3 In the **Internet Connection Properties** window, click **Settings** to see the port mappings there were automatically created.

Figure 70 Internet Connection Properties



- 4 You may edit or delete the port mappings or click **Add** to manually add port mappings.

Figure 71 Internet Connection Properties: Advanced Settings

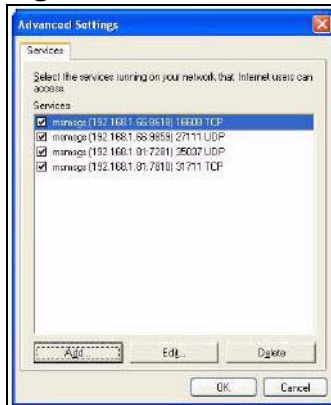

Figure 72 Internet Connection Properties: Advanced Settings: Add



Note: When the UPnP-enabled device is disconnected from your computer, all port mappings will be deleted automatically.

- 5 Select **Show icon in notification area when connected** option and click **OK**. An icon displays in the system tray.

Figure 73 System Tray Icon



- 6 Double-click on the icon to display your current Internet connection status.

Figure 74 Internet Connection Status



14.4.2 Web Configurator Easy Access

With UPnP, you can access the web-based configurator on the NBG-416N without finding out the IP address of the NBG-416N first. This comes helpful if you do not know the IP address of the NBG-416N.

Follow the steps below to access the Web Configurator.

- 1 Click **Start** and then **Control Panel**.
- 2 Double-click **Network Connections**.

3 Select **My Network Places** under **Other Places**.

Figure 75 Network Connections

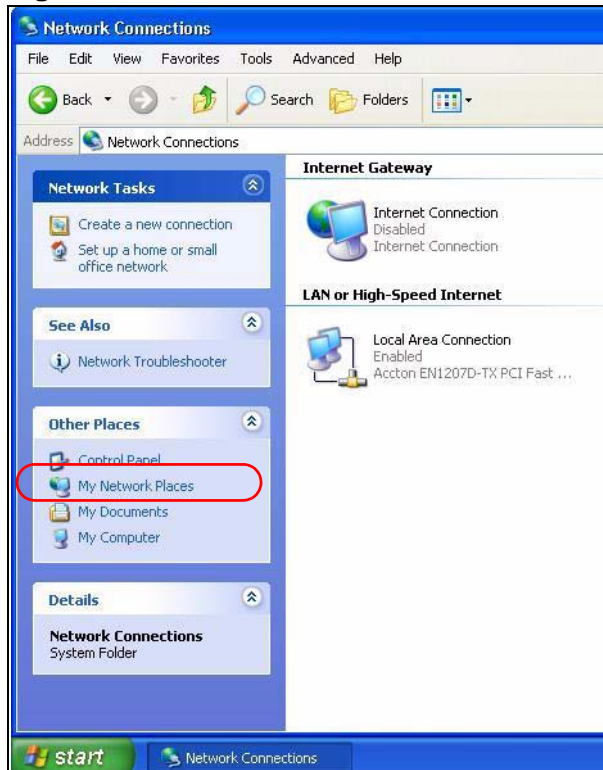

4 An icon with the description for each UPnP-enabled device displays under **Local Network**.

5 Right-click on the icon for your NBG-416N and select **Invoke**. The Web Configurator login screen displays.

Figure 76 Network Connections: My Network Places



15.1 Overview

This chapter provides information on the **System** screens.

See the chapter about wizard setup for more information on the next few screens.

15.2 What You Can Do

- Use the **General** screen to enter a name to identify the NBG-416N in the network and set the password ([Section 15.3 on page 125](#)).
- Use the **Time Setting** screen to change your NBG-416N's time and date ([Section 15.4 on page 127](#)).

15.3 System General Screen

Use this screen to enter a name to identify the NBG-416N in the network and set the password. Click **Maintenance > System**. The following screen displays.

Figure 77 Maintenance > System > General

The screenshot shows a web interface for system configuration. At the top, there are two tabs: "General" (selected) and "Time Setting". Below the tabs is a "System Setup" section with three input fields: "System Name" (containing "NBG-416N"), "Domain Name" (empty), and "Administrator Inactivity Timer" (containing "5" with a note "(minutes, 0 means no timeout)"). Below this is a "Password Setup" section with three password input fields: "Old Password", "New Password", and "Retype to Confirm", each containing four dots. At the bottom of the form are "Apply" and "Reset" buttons.

The following table describes the labels in this screen.

Table 47 Maintenance > System > General

LABEL	DESCRIPTION
System Setup	
System Name	<p>System Name is a unique name to identify the NBG-416N in an Ethernet network. It is recommended you enter your computer's "Computer name" in this field (see the chapter about wizard setup for how to find your computer's name).</p> <p>This name can be up to 30 alphanumeric characters long. Spaces are not allowed, but dashes "-" and underscores "_" are accepted.</p>
Domain Name	<p>Enter the domain name (if you know it) here. If you leave this field blank, the ISP may assign a domain name via DHCP.</p> <p>The domain name entered by you is given priority over the ISP assigned domain name.</p>
Administrator Inactivity Timer	<p>Type how many minutes a management session can be left idle before the session times out. The default is 5 minutes. After it times out you have to log in with your password again. Very long idle timeouts may have security risks. A value of "0" means a management session never times out, no matter how long it has been left idle (not recommended).</p>
Password Setup	<p>Change your NBG-416N's password (recommended) using the fields as shown.</p>
Old Password	<p>Type the default password or the existing password you use to access the system in this field.</p>
New Password	<p>Type your new system password (up to 30 characters). Note that as you type a password, the screen displays an asterisk (*) for each character you type.</p>
Retype to Confirm	<p>Type the new password again in this field.</p>
Apply	<p>Click Apply to save your changes back to the NBG-416N.</p>
Reset	<p>Click Reset to begin configuring this screen afresh.</p>

15.4 Time Setting Screen

To change your NBG-416N's time and date, click **Maintenance > System > Time Setting**. The screen appears as shown. Use this screen to configure the NBG-416N's time based on your local time zone.

Figure 78 Maintenance > System > Time Setting

The following table describes the labels in this screen.

Table 48 Maintenance > System > Time Setting

LABEL	DESCRIPTION
Current Time and Date	
Current Time	This field displays the time of your NBG-416N. Each time you reload this page, the NBG-416N synchronizes the time with the time server.
Current Date	This field displays the date of your NBG-416N. Each time you reload this page, the NBG-416N synchronizes the date with the time server.
Time and Date Setup	
Manual	Select this radio button to enter the time and date manually. If you configure a new time and date, Time Zone and Daylight Saving at the same time, the new time and date you entered has priority and the Time Zone and Daylight Saving settings do not affect it.
Copy Your Computer's Time Settings	Click this to copy the time settings of your computer into the NBG-416N's time and date setup.

Table 48 Maintenance > System > Time Setting (continued)

LABEL	DESCRIPTION
New Time (hh:mm:ss)	This field displays the last updated time from the time server or the last time configured manually. When you set Time and Date Setup to Manual , enter the new time in this field and then click Apply .
New Date (yyyy/mm/dd)	This field displays the last updated date from the time server or the last date configured manually. When you set Time and Date Setup to Manual , enter the new date in this field and then click Apply .
Get from Time Server	Select this radio button to have the NBG-416N get the time and date from the time server you specified below.
Auto	Select Auto to have the NBG-416N automatically search for an available time server and synchronize the date and time with the time server after you click Apply .
User Defined Time Server Address	Select User Defined Time Server Address and enter the IP address or URL (up to 20 extended ASCII characters in length) of your time server. Check with your ISP/network administrator if you are unsure of this information.
Time Zone Setup	
Time Zone	Choose the time zone of your location. This will set the time difference between your time zone and Greenwich Mean Time (GMT).
Daylight Savings	Daylight saving is a period from late spring to early fall when many countries set their clocks ahead of normal local time by one hour to give more daytime light in the evening. Select this option if you use Daylight Saving Time.
Start Date	Configure the day and time when Daylight Saving Time starts if you selected Daylight Savings . The o'clock field uses the 24 hour format. Here are a couple of examples: Daylight Saving Time starts in most parts of the United States on the first Sunday of April. Each time zone in the United States starts using Daylight Saving Time at 2 A.M. local time. So in the United States you would select First, Sunday, April and type 2 in the o'clock field. Daylight Saving Time starts in the European Union on the last Sunday of March. All of the time zones in the European Union start using Daylight Saving Time at the same moment (1 A.M. GMT or UTC). So in the European Union you would select Last, Sunday, March . The time you type in the o'clock field depends on your time zone. In Germany for instance, you would type 2 because Germany's time zone is one hour ahead of GMT or UTC (GMT+1).

Table 48 Maintenance > System > Time Setting (continued)

LABEL	DESCRIPTION
End Date	<p>Configure the day and time when Daylight Saving Time ends if you selected Daylight Savings. The o'clock field uses the 24 hour format. Here are a couple of examples:</p> <p>Daylight Saving Time ends in the United States on the last Sunday of October. Each time zone in the United States stops using Daylight Saving Time at 2 A.M. local time. So in the United States you would select Last, Sunday, October and type 2 in the o'clock field.</p> <p>Daylight Saving Time ends in the European Union on the last Sunday of October. All of the time zones in the European Union stop using Daylight Saving Time at the same moment (1 A.M. GMT or UTC). So in the European Union you would select Last, Sunday, October. The time you type in the o'clock field depends on your time zone. In Germany for instance, you would type 2 because Germany's time zone is one hour ahead of GMT or UTC (GMT+1).</p>
Apply	Click Apply to save your changes back to the NBG-416N.
Reset	Click Reset to begin configuring this screen afresh.

16.1 Overview

This chapter contains information about configuring general log settings and viewing the NBG-416N's logs.

The Web Configurator allows you to look at all of the NBG-416N's logs in one location.

16.2 What You Need to Know

An alert is a type of log that warrants more serious attention. They include system errors, attacks (access control) and attempted access to blocked web sites or web sites with restricted web features such as cookies, active X and so on. Some categories such as **System Errors** consist of both logs and alerts. You may differentiate them by their color in the **View Log** screen. Alerts display in red and logs display in black.

Alerts are e-mailed as soon as they happen. Logs may be e-mailed as soon as the log is full (see **Log Schedule**). Selecting many alert and/or log categories (especially **Access Control**) may result in many e-mails being sent.

16.3 View Log Screen

Use the **View Log** screen to see the logged messages for the NBG-416N. Options include logs about system maintenance, system errors, access control, allowed or blocked web sites, blocked web features (such as ActiveX controls, Java and cookies), attacks (such as DoS) and IPSec.

Log entries in red indicate system error logs. The log wraps around and deletes the old entries after it fills. Click a column heading to sort the entries. A triangle indicates ascending or descending sort order.

Click **Maintenance > Logs** to open the **View Log** screen.

Figure 79 Maintenance > Logs > View Log

#	Time	Message
1	Jan 1 00:00:04	started: BusyBox v1.17.3
2	Jan 1 00:00:04	Syslog daemon successfully started
3	Jan 1 00:00:07	Start WAN SETUP: wkmode=router wan_hwname=eth1 protocol=dhcp method=BOOT
4	Jan 1 00:00:07	Finish WAN SETUP: wkmode=router wan_hwname=eth1 protocol=dhcp method=BOOT
5	Jan 1 00:00:07	started, version 2.55 cachesize 150
6	Jan 1 00:00:07	compile time options: no-IPv6 GNU-getopt no-DBus no-I18N DHCP no-scripts no-TFTP
7	Jan 1 00:00:07	DHCP, IP range 192.168.1.33 -- 192.168.1.132, lease time 24m
8	Jan 1 00:00:07	reading /tmp/resolv.dnsmasq
9	Jan 1 00:00:07	using nameserver 4.2.2.4#53
10	Jan 1 00:00:07	using nameserver 156.154.70.1#53
11	Jan 1 00:00:07	using nameserver 168.126.63.1#53
12	Jan 1 00:00:07	read /etc/hosts - 0 addresses
13	Jan 1 00:00:07	read /tmp/hosts - 0 addresses
14	Jan 1 05:19:16	DHCPDISCOVER(br0) 172.23.26.4 00:24:21:7e:20:96
15	Jan 1 05:19:16	DHCPOFFER(br0) 192.168.1.83 00:24:21:7e:20:96
16	Jan 1 05:19:16	DHCPREQUEST(br0) 192.168.1.83 00:24:21:7e:20:96
17	Jan 1 05:19:16	DHCPACK(br0) 192.168.1.83 00:24:21:7e:20:96 twpc13774-02
18	Jan 1 05:19:16	Ignoring domain ZyXEL.com for DHCP host name twpc13774-02
19	Jan 1 05:33:50	DHCPREQUEST(br0) 172.23.26.4 00:24:21:7e:20:96
20	Jan 1 05:33:50	DHCNACK(br0) 172.23.26.4 00:24:21:7e:20:96 lease not found

The following table describes the labels in this screen.

Table 49 Maintenance > Logs > View Log

LABEL	DESCRIPTION
Refresh	Click Refresh to renew the log screen.
Clear Logs	Click Clear Logs to delete all the logs.
Next	Click Next to show the next page of log entries.
Last	Click Last to show the last page of log entries.
#	This is the index number of the log entry.
Time	This field displays the time the log was recorded. See the chapter on system maintenance and information to configure the NBG-416N's time and date.
Message	This field states the reason for the log.

17.1 Overview

This chapter shows you how to upload a new firmware, upload or save backup configuration files and restart the NBG-416N.

17.2 What You Can Do

- Use the **Firmware** screen to upload firmware to your NBG-416N ([Section 17.3 on page 133](#)).
- Use the **Configuration** screen to view information related to factory defaults, backup configuration, and restoring configuration ([Section 17.4 on page 136](#)).
- Use the **Restart** screen to have the NBG-416N reboot ([Section 17.5 on page 138](#)).

17.3 Firmware Upload Screen

Find firmware at www.zyxel.com in a file that (usually) uses the system model name with a ".bin" extension, e.g., "NBG-416N.bin". The upload process uses HTTP (Hypertext Transfer Protocol) and may take up to two minutes. After a successful upload, the system will reboot.

Click **Maintenance > Tools**. Follow the instructions in this screen to upload firmware to your NBG-416N.

Figure 80 Maintenance > Tools > Firmware

The following table describes the labels in this screen.

Table 50 Maintenance > Tools > Firmware

LABEL	DESCRIPTION
File Path	Type in the location of the file you want to upload in this field or click Browse... to find it.
Browse...	Click Browse... to find the .bin file you want to upload. Remember that you must decompress compressed (.zip) files before you can upload them.
Upload	Click Upload to begin the upload process. This process may take up to two minutes.

Note: Do not turn off the NBG-416N while firmware upload is in progress!

After you see the **Firmware Upload In Process** screen, wait for several minutes before logging into the NBG-416N again.

Figure 81 Upload Warning

The NBG-416N automatically restarts in this time causing a temporary network disconnect. In some operating systems, you may see the following icon on your desktop.

Figure 82 Network Temporarily Disconnected

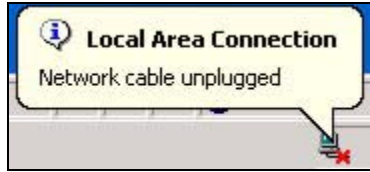

After two minutes, log in again and check your new firmware version in the **Status** screen.

If the upload was not successful, the following screen will appear. Click **Return** to go back to the **Firmware** screen.

Figure 83 Upload Error Message



17.4 Configuration Screen

Click **Maintenance > Tools > Configuration**. Information related to factory defaults, backup configuration, and restoring configuration appears as shown next.

Figure 84 Maintenance > Tools > Configuration

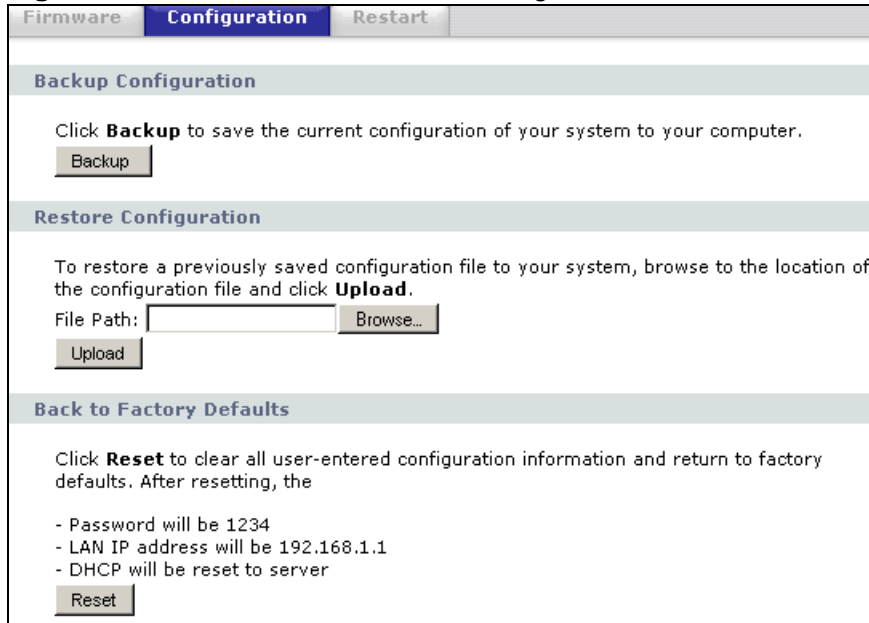

The screenshot shows a web interface with three tabs: 'Firmware', 'Configuration' (selected), and 'Restart'. Below the tabs are three sections:

- Backup Configuration:** Contains the text 'Click **Backup** to save the current configuration of your system to your computer.' and a 'Backup' button.
- Restore Configuration:** Contains the text 'To restore a previously saved configuration file to your system, browse to the location of the configuration file and click **Upload**.' Below this is a 'File Path:' label, an empty text input field, a 'Browse...' button, and an 'Upload' button.
- Back to Factory Defaults:** Contains the text 'Click **Reset** to clear all user-entered configuration information and return to factory defaults. After resetting, the' followed by a bulleted list:
 - Password will be 1234
 - LAN IP address will be 192.168.1.1
 - DHCP will be reset to serverand a 'Reset' button.

17.4.1 Backup Configuration

Backup configuration allows you to back up (save) the NBG-416N's current configuration to a file on your computer. Once your NBG-416N is configured and functioning properly, it is highly recommended that you back up your configuration file before making configuration changes. The backup configuration file will be useful in case you need to return to your previous settings.

Click **Backup** to save the NBG-416N's current configuration to your computer.

17.4.2 Restore Configuration

Restore configuration allows you to upload a new or previously saved configuration file from your computer to your NBG-416N.

Table 51 Maintenance Restore Configuration

LABEL	DESCRIPTION
File Path	Type in the location of the file you want to upload in this field or click Browse... to find it.
Browse...	Click Browse... to find the file you want to upload. Remember that you must decompress compressed (.ZIP) files before you can upload them.
Upload	Click Upload to begin the upload process.

Note: Do not turn off the NBG-416N while configuration file upload is in progress.

After you see a “configuration upload successful” screen, you must then wait one minute before logging into the NBG-416N again.

Figure 85 Configuration Restore Successful



The NBG-416N automatically restarts in this time causing a temporary network disconnect. In some operating systems, you may see the following icon on your desktop.

Figure 86 Temporarily Disconnected



If you uploaded the default configuration file you may need to change the IP address of your computer to be in the same subnet as that of the default NBG-416N IP address (192.168.1.1). See [Appendix C on page 175](#) for details on how to set up your computer’s IP address.

If the upload was not successful, the following screen will appear. Click **Return** to go back to the **Configuration** screen.

Figure 87 Configuration Restore Error



17.4.3 Back to Factory Defaults

Pressing the **Reset** button in this section clears all user-entered configuration information and returns the NBG-416N to its factory defaults.

You can also press the **RESET** button on the rear panel to reset the factory defaults of your NBG-416N. Refer to [Section 3.3.1 on page 27](#) for more information on the **RESET** button.

17.5 Restart Screen

System restart allows you to reboot the NBG-416N without turning the power off.

Click **Maintenance > Tools > Restart**. Click **Restart** to have the NBG-416N reboot. This does not affect the NBG-416N's configuration.

Figure 88 Maintenance > Tools > Restart

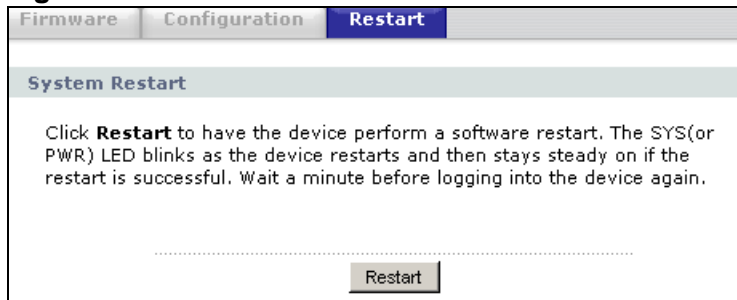

Sys OP Mode

18.1 Overview

The **Sys OP Mode** (System Operation Mode) function lets you configure whether your NBG-416N is a router or AP.

You can choose between **Router Mode** and **AP Mode** depending on your network topology and the features you require from your device. See [Section 1.1 on page 19](#) for more information on which mode to choose.

18.2 What You Need to Know

Router

A router connects your local network with another network, such as the Internet. The router has two IP addresses, the LAN IP address and the WAN IP address.

Figure 89 LAN and WAN IP Addresses in Router Mode

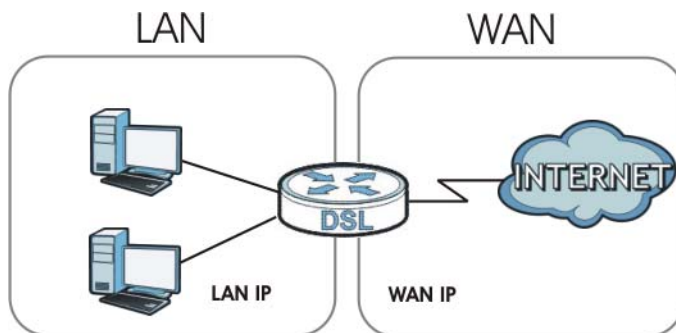

AP

An AP extends one network and so has just one IP address. All Ethernet ports on the AP have the same IP address. To connect to the Internet, another device, such as a router, is required.

Figure 90 IP Address in AP Mode

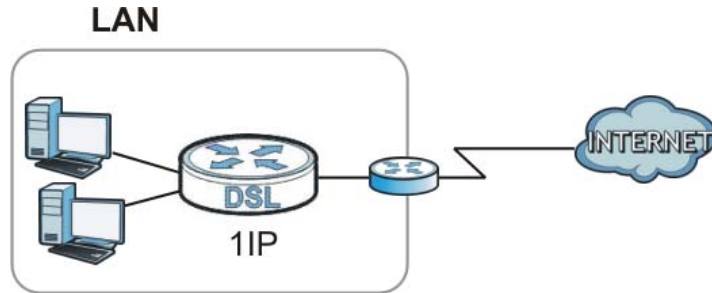

18.3 General Screen

Use this screen to select how you connect to the Internet.

Figure 91 Maintenance > Sys OP Mode > General

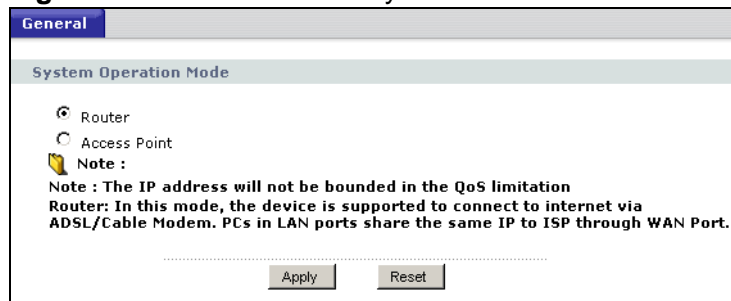

If you select **Router** mode, the following pop-up message window appears.

Figure 92 Maintenance > Sys Op Mode > General: Router

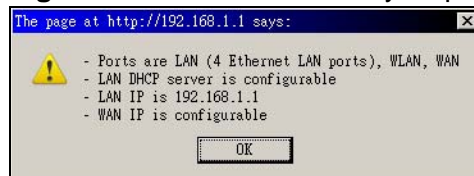

- In this mode there are both LAN and WAN ports. The LAN Ethernet and WAN Ethernet ports have different IP addresses.
- The DHCP server on your device is enabled and allocates IP addresses to other devices on your local network.
- The LAN IP address of the device on the local network is set to 192.168.1.1.

- You can configure the IP address settings on your WAN port. Contact your ISP or system administrator for more information on appropriate settings.

If you select Access Point the following pop-up message window appears.

Figure 93 Maintenance > Sys Op Mode > General: AP



- In **AP Mode** all Ethernet ports have the same IP address.
- All ports on the rear panel of the device are LAN ports, including the port labeled WAN. There is no WAN port.
- The DHCP server on your device is disabled. In AP mode there must be a device with a DHCP server on your network such as a router or gateway which can allocate IP addresses.

The IP address of the device on the local network is set to 192.168.1.2.

The following table describes the labels in the **General** screen.

Table 52 Maintenance > Sys Op Mode > General

LABEL	DESCRIPTION
System Operation Mode	
Router	Select Router if your device routes traffic between a local network and another network such as the Internet. This mode offers services such as a firewall or content filter.
Access Point	Select Access Point if your device bridges traffic between clients on the same network.
Apply	Click Apply to save your settings.
Reset	Click Reset to return your settings to the default (Router).

Note: If you select the incorrect System Operation Mode, you cannot connect to the Internet.

Language

19.1 Language Screen

Use this screen to change the language for the Web Configurator display.

Click the language you prefer. The Web Configurator language changes after a while without restarting the NBG-416N.

Figure 94 Language



Troubleshooting

This chapter offers some suggestions to solve problems you might encounter. The potential problems are divided into the following categories.

- [Power, Hardware Connections, and LEDs](#)
- [NBG-416N Access and Login](#)
- [Internet Access](#)
- [Resetting the NBG-416N to Its Factory Defaults](#)
- [Wireless Router/AP Troubleshooting](#)

20.1 Power, Hardware Connections, and LEDs

The NBG-416N does not turn on. None of the LEDs turn on.

- 1 Make sure you are using the power adaptor or cord included with the NBG-416N.
- 2 Make sure the power adaptor or cord is connected to the NBG-416N and plugged in to an appropriate power source. Make sure the power source is turned on.
- 3 Disconnect and re-connect the power adaptor or cord to the NBG-416N.
- 4 If the problem continues, contact the vendor.

One of the LEDs does not behave as expected.

- 1 Make sure you understand the normal behavior of the LED. See [Section 1.5 on page 20](#).
- 2 Check the hardware connections. See the Quick Start Guide.

- 3 Inspect your cables for damage. Contact the vendor to replace any damaged cables.
- 4 Disconnect and re-connect the power adaptor to the NBG-416N.
- 5 If the problem continues, contact the vendor.

20.2 NBG-416N Access and Login

I don't know the IP address of my NBG-416N.

- 1 The default IP address is **192.168.1.1**.
- 2 If you changed the IP address and have forgotten it, you might get the IP address of the NBG-416N by looking up the IP address of the default gateway for your computer. To do this in most Windows computers, click **Start > Run**, enter **cmd**, and then enter **ipconfig**. The IP address of the **Default Gateway** might be the IP address of the NBG-416N (it depends on the network), so enter this IP address in your Internet browser. Set your device to **Router Mode**, login (see the Quick Start Guide for instructions) and go to the **Device Information** table in the **Status** screen. Your NBG-416N's IP address is available in the **Device Information** table.
 - If the **DHCP** setting under **LAN information** is **None**, your device has a fixed IP address.
 - If the **DHCP** setting under **LAN information** is **Client**, then your device receives an IP address from a DHCP server on the network.
- 3 If your NBG-416N is a DHCP client, you can find your IP address from the DHCP server. This information is only available from the DHCP server which allocates IP addresses on your network. Find this information directly from the DHCP server or contact your system administrator for more information.
- 4 Reset your NBG-416N to change all settings back to their default. This means your current settings are lost. See [Section 20.4 on page 149](#) in the **Troubleshooting** for information on resetting your NBG-416N.

I forgot the username and password.

- 1 The default username is **admin** and default password is **1234**.

- 2 If this does not work, you have to reset the device to its factory defaults. See [Section 20.4 on page 149](#).

I cannot see or access the **Login** screen in the Web Configurator.

- 1 Make sure you are using the correct IP address.
 - The default IP address is [192.168.1.1](#).
 - If you changed the IP address ([Section 7.3 on page 102](#)), use the new IP address.
 - If you changed the IP address and have forgotten it, see the troubleshooting suggestions for [I don't know the IP address of my NBG-416N](#).
- 2 Check the hardware connections, and make sure the LEDs are behaving as expected. See the Quick Start Guide.
- 3 Make sure your Internet browser does not block pop-up windows and has JavaScript and Java enabled. See [Appendix B on page 167](#).
- 4 Make sure your computer is in the same subnet as the NBG-416N. (If you know that there are routers between your computer and the NBG-416N, skip this step.)
 - If there is a DHCP server on your network, make sure your computer is using a dynamic IP address. See [Section 7.3 on page 102](#).
 - If there is no DHCP server on your network, make sure your computer's IP address is in the same subnet as the NBG-416N. See [Section 7.3 on page 102](#).
- 5 Reset the device to its factory defaults, and try to access the NBG-416N with the default IP address. See [Section 7.3 on page 102](#).
- 6 If the problem continues, contact the network administrator or vendor, or try one of the advanced suggestions.

Advanced Suggestions

- If your computer is connected to the **WAN** port or is connected wirelessly, use a computer that is connected to a **LAN/ETHERNET** port.

I can see the **Login** screen, but I cannot log in to the NBG-416N.

- 1 Make sure you have entered the password correctly. The default username is **admin** and default password is **1234**. This field is case-sensitive, so make sure [Caps Lock] is not on.
- 2 This can happen when you fail to log out properly from your last session. Try logging in again after 5 minutes.
- 3 Disconnect and re-connect the power adaptor or cord to the NBG-416N.
- 4 If this does not work, you have to reset the device to its factory defaults. See [Section 20.4 on page 149](#).

20.3 Internet Access

I cannot access the Internet.

- 1 Check the hardware connections, and make sure the LEDs are behaving as expected. See the Quick Start Guide.
- 2 Make sure you entered your ISP account information correctly in the wizard. These fields are case-sensitive, so make sure [Caps Lock] is not on.
- 3 If you are trying to access the Internet wirelessly, make sure the wireless settings in the wireless client are the same as the settings in the AP.
- 4 Disconnect all the cables from your device, and follow the directions in the Quick Start Guide again.
- 5 Go to **Maintenance > Sys OP Mode > General**. Check your **System Operation Mode** setting.
 - Select **Router** if your device routes traffic between a local network and another network such as the Internet.
 - Select **Access Point** if your device bridges traffic between clients on the same network.
- 6 If the problem continues, contact your ISP.

I cannot access the Internet anymore. I had access to the Internet (with the NBG-416N), but my Internet connection is not available anymore.

- 1 Check the hardware connections, and make sure the LEDs are behaving as expected. See the Quick Start Guide and [Section 1.5 on page 20](#).
- 2 Reboot the NBG-416N.
- 3 If the problem continues, contact your ISP.

The Internet connection is slow or intermittent.

- 1 There might be a lot of traffic on the network. Look at the LEDs, and check [Section 1.5 on page 20](#). If the NBG-416N is sending or receiving a lot of information, try closing some programs that use the Internet, especially peer-to-peer applications.
- 2 Check the signal strength. If the signal strength is low, try moving the NBG-416N closer to the AP if possible, and look around to see if there are any devices that might be interfering with the wireless network (for example, microwaves, other wireless networks, and so on).
- 3 Reboot the NBG-416N.
- 4 If the problem continues, contact the network administrator or vendor, or try one of the advanced suggestions.

Advanced Suggestion

- Check the settings for QoS. If it is disabled, you might consider activating it.

20.4 Resetting the NBG-416N to Its Factory Defaults

If you reset the NBG-416N, you lose all of the changes you have made. The NBG-416N re-loads its default settings, and the username/password resets to **admin/1234**. You have to make all of your changes again.

You will lose all of your changes when you push the **RESET** button.

To reset the NBG-416N,

- 1 Make sure the power LED is on.

- 2 Press the **RESET** button for longer than 1 second to restart/reboot the NBG-416N.
- 3 Press the **RESET** button for longer than five seconds to set the NBG-416N back to its factory-default configurations.

If the NBG-416N restarts automatically, wait for the NBG-416N to finish restarting, and log in to the Web Configurator. The username is **admin** and password is **1234**.

If the NBG-416N does not restart automatically, disconnect and reconnect the NBG-416N's power. Then, follow the directions above again.

20.5 Wireless Router/AP Troubleshooting

I cannot access the NBG-416N or ping any computer from the WLAN (wireless AP or router).

- 1 Make sure the wireless LAN is enabled on the NBG-416N.
- 2 Make sure the wireless adapter on the wireless station is working properly.
- 3 Make sure the wireless adapter installed on your computer is IEEE 802.11 compatible and supports the same wireless standard as the NBG-416N.
- 4 Make sure your computer (with a wireless adapter installed) is within the transmission range of the NBG-416N.
- 5 Check that both the NBG-416N and your wireless station are using the same wireless and wireless security settings.
- 6 Make sure traffic between the WLAN and the LAN is not blocked by the firewall on the NBG-416N.
- 7 Make sure you allow the NBG-416N to be remotely accessed through the WLAN interface. Check your remote management settings.
 - See [Chapter 7 Wireless LAN](#) for more information.

I can access the Web Configurator after I switched to AP mode.

When you change from router mode to AP mode, your computer must have an IP address in the range between "192.168.1.3" and "192.168.1.254".

Refer to [Appendix C on page 175](#) for instructions on how to change your computer's IP address.

Product Specifications

The following tables summarize the NBG-416N's hardware and firmware features.

Table 53 Hardware Features

Dimensions (W x D x H)	162 mm x 115 mm x 33 mm
Weight	216 g
Power Specification	Input: 100 -- 240VAC, 50/60 Hz Output: 5VDC /1A
Ethernet ports	Auto-negotiating: 10 Mbps, 100 Mbps in either half-duplex or full-duplex mode. Auto-crossover: Use either crossover or straight-through Ethernet cables.
4-5 Port Switch	A combination of switch and router makes your NBG-416N a cost-effective and viable network solution. You can add up to four computers to the NBG-416N without the cost of a hub when connecting to the Internet through the WAN port. You can add up to five computers to the NBG-416N when you connect to the Internet in AP mode. Add more than four computers to your LAN by using a hub.
LEDs	PWR, LAN1-4, WAN, WLAN, WPS
Reset Button	The reset button is built into the rear panel. Use this button to restore the NBG-416N to its factory default settings. Press for 1 second to restart the device. Press for 5 seconds to restore to factory default settings.
WPS button	Press the WPS on two WPS enabled devices within 120 seconds for a security-enabled wireless connection.
Antenna	The NBG-416N is equipped with a 2.4GHz detachable antenna to provide clear radio transmission and reception on the wireless network.
Operation Environment	Temperature: 0° C ~ 40° C / 32°F ~ 104°F Humidity: 20% ~ 90%
Storage Environment	Temperature: -30° C ~ 70° C / -22°F ~ 158°F Humidity: 20% ~ 95%

Table 54 Firmware Features

FEATURE	DESCRIPTION
Default LAN IP Address	192.168.1.1 (router) 192.168.1.2. (AP)
Default LAN Subnet Mask	255.255.255.0 (24 bits)
Default Username	admin
Default Password	1234
DHCP Pool	192.168.1.33 to 192.168.1.64
Wireless Interface	Wireless LAN
Default Wireless SSID	ZyXEL
Device Management	Use the Web Configurator to easily configure the rich range of features on the NBG-416N.
Wireless Functionality	Allows IEEE802.11b, IEEE802.11g, and/or IEEE 802.11n wireless clients to connect to the NBG-416N wirelessly. Enable wireless security (WPA(2)-PSK) and/or MAC filtering to protect your wireless network. Note: The NBG-416N may be prone to RF (Radio Frequency) interference from other 2.4 GHz devices such as microwave ovens, wireless phones, Bluetooth enabled devices, and other wireless LANs.
Firmware Upgrade	Download new firmware (when available) from the ZyXEL web site and use the Web Configurator to put it on the NBG-416N. Note: Only upload firmware for your specific model!
Configuration Backup & Restoration	Make a copy of the NBG-416N's configuration and put it back on the NBG-416N later if you decide you want to revert back to an earlier configuration.
Network Address Translation (NAT)	Each computer on your network must have its own unique IP address. Use NAT to convert a single public IP address to multiple private IP addresses for the computers on your network.
Firewall	You can configure firewall on the NBG-416N for secure Internet access. When the firewall is on, by default, all incoming traffic from the Internet to your network is blocked unless it is initiated from your network. This means that probes from the outside to your network are not allowed, but you can safely browse the Internet and download files for example.
Remote Management	This allows you to decide whether a service (HTTP or FTP traffic for example) from a computer on a network (LAN or WAN for example) can access the NBG-416N.
Wireless LAN Scheduler	You can schedule the times the Wireless LAN is enabled/ disabled.

Table 54 Firmware Features (continued)

FEATURE	DESCRIPTION
Time and Date	Get the current time and date from an external server when you turn on your NBG-416N. You can also set the time manually. These dates and times are then used in logs.
Port Forwarding	If you have a server (mail or web server for example) on your network, then use this feature to let people access it from the Internet.
DHCP (Dynamic Host Configuration Protocol)	Use this feature to have the NBG-416N assign IP addresses, an IP default gateway and DNS servers to computers on your network.
Logging	Use logs for troubleshooting. You can view logs in the Web Configurator.
PPPoE	PPPoE mimics a dial-up Internet access connection.
PPTP Encapsulation	Point-to-Point Tunneling Protocol (PPTP) enables secure transfer of data through a Virtual Private Network (VPN). The NBG-416N supports one PPTP connection at a time.
Universal Plug and Play (UPnP)	The NBG-416N can communicate with other UPnP enabled devices in a network.

IP Addresses and Subnetting

This appendix introduces IP addresses and subnet masks.

IP addresses identify individual devices on a network. Every networking device (including computers, servers, routers, printers, etc.) needs an IP address to communicate across the network. These networking devices are also known as hosts.

Subnet masks determine the maximum number of possible hosts on a network. You can also use subnet masks to divide one network into multiple sub-networks.

Introduction to IP Addresses

One part of the IP address is the network number, and the other part is the host ID. In the same way that houses on a street share a common street name, the hosts on a network share a common network number. Similarly, as each house has its own house number, each host on the network has its own unique identifying number - the host ID. Routers use the network number to send packets to the correct network, while the host ID determines to which host on the network the packets are delivered.

Structure

An IP address is made up of four parts, written in dotted decimal notation (for example, 192.168.1.1). Each of these four parts is known as an octet. An octet is an eight-digit binary number (for example 11000000, which is 192 in decimal notation).

Therefore, each octet has a possible range of 00000000 to 11111111 in binary, or 0 to 255 in decimal.

The following figure shows an example IP address in which the first three octets (192.168.1) are the network number, and the fourth octet (16) is the host ID.

Figure 95 Network Number and Host ID

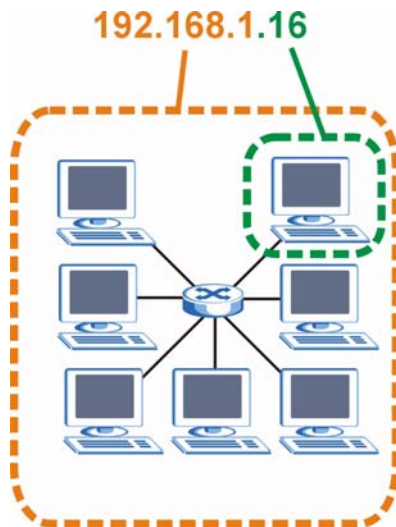

How much of the IP address is the network number and how much is the host ID varies according to the subnet mask.

Subnet Masks

A subnet mask is used to determine which bits are part of the network number, and which bits are part of the host ID (using a logical AND operation). The term “subnet” is short for “sub-network”.

A subnet mask has 32 bits. If a bit in the subnet mask is a “1” then the corresponding bit in the IP address is part of the network number. If a bit in the subnet mask is “0” then the corresponding bit in the IP address is part of the host ID.

The following example shows a subnet mask identifying the network number (in bold text) and host ID of an IP address (192.168.1.2 in decimal).

Table 55 Subnet Mask - Identifying Network Number

	1ST OCTET: (192)	2ND OCTET: (168)	3RD OCTET: (1)	4TH OCTET (2)
IP Address (Binary)	11000000	10101000	00000001	00000010
Subnet Mask (Binary)	11111111	11111111	11111111	00000000

Table 55 Subnet Mask - Identifying Network Number

	1ST OCTET: (192)	2ND OCTET: (168)	3RD OCTET: (1)	4TH OCTET (2)
Network Number	11000000	10101000	00000001	
Host ID				00000010

By convention, subnet masks always consist of a continuous sequence of ones beginning from the leftmost bit of the mask, followed by a continuous sequence of zeros, for a total number of 32 bits.

Subnet masks can be referred to by the size of the network number part (the bits with a “1” value). For example, an “8-bit mask” means that the first 8 bits of the mask are ones and the remaining 24 bits are zeroes.

Subnet masks are expressed in dotted decimal notation just like IP addresses. The following examples show the binary and decimal notation for 8-bit, 16-bit, 24-bit and 29-bit subnet masks.

Table 56 Subnet Masks

	BINARY				DECIMAL
	1ST OCTET	2ND OCTET	3RD OCTET	4TH OCTET	
8-bit mask	11111111	00000000	00000000	00000000	255.0.0.0
16-bit mask	11111111	11111111	00000000	00000000	255.255.0.0
24-bit mask	11111111	11111111	11111111	00000000	255.255.255.0
29-bit mask	11111111	11111111	11111111	11111000	255.255.255.248

Network Size

The size of the network number determines the maximum number of possible hosts you can have on your network. The larger the number of network number bits, the smaller the number of remaining host ID bits.

An IP address with host IDs of all zeros is the IP address of the network (192.168.1.0 with a 24-bit subnet mask, for example). An IP address with host IDs of all ones is the broadcast address for that network (192.168.1.255 with a 24-bit subnet mask, for example).

As these two IP addresses cannot be used for individual hosts, calculate the maximum number of possible hosts in a network as follows:

Table 57 Maximum Host Numbers

SUBNET MASK		HOST ID SIZE		MAXIMUM NUMBER OF HOSTS
8 bits	255.0.0.0	24 bits	$2^{24} - 2$	16777214
16 bits	255.255.0.0	16 bits	$2^{16} - 2$	65534
24 bits	255.255.255.0	8 bits	$2^8 - 2$	254
29 bits	255.255.255.248	3 bits	$2^3 - 2$	6

Notation

Since the mask is always a continuous number of ones beginning from the left, followed by a continuous number of zeros for the remainder of the 32 bit mask, you can simply specify the number of ones instead of writing the value of each octet. This is usually specified by writing a "/" followed by the number of bits in the mask after the address.

For example, 192.1.1.0 /25 is equivalent to saying 192.1.1.0 with subnet mask 255.255.255.128.

The following table shows some possible subnet masks using both notations.

Table 58 Alternative Subnet Mask Notation

SUBNET MASK	ALTERNATIVE NOTATION	LAST OCTET (BINARY)	LAST OCTET (DECIMAL)
255.255.255.0	/24	0000 0000	0
255.255.255.128	/25	1000 0000	128
255.255.255.192	/26	1100 0000	192
255.255.255.224	/27	1110 0000	224
255.255.255.240	/28	1111 0000	240
255.255.255.248	/29	1111 1000	248
255.255.255.252	/30	1111 1100	252

Subnetting

You can use subnetting to divide one network into multiple sub-networks. In the following example a network administrator creates two sub-networks to isolate a group of servers from the rest of the company network for security reasons.

In this example, the company network address is 192.168.1.0. The first three octets of the address (192.168.1) are the network number, and the remaining octet is the host ID, allowing a maximum of $2^8 - 2$ or 254 possible hosts.

The following figure shows the company network before subnetting.

Figure 96 Subnetting Example: Before Subnetting

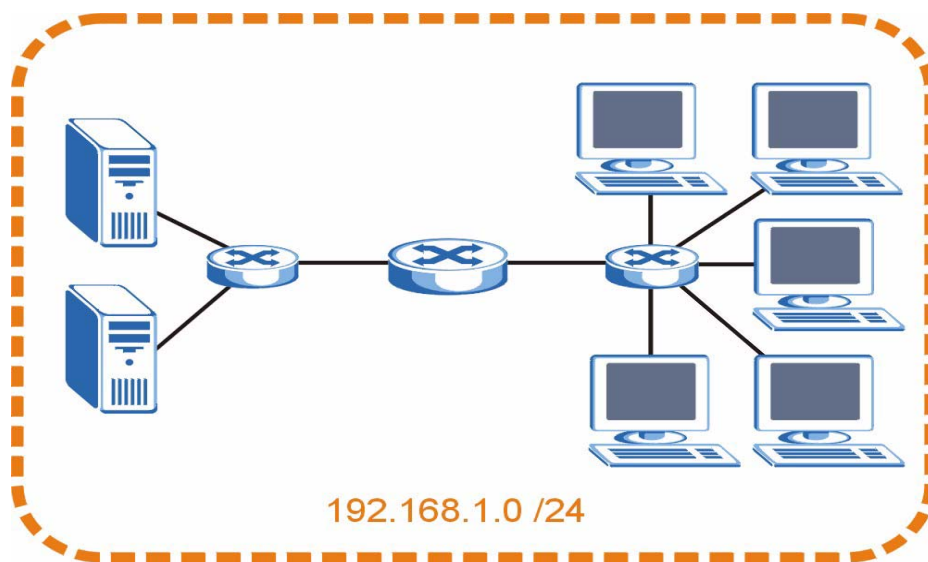

You can “borrow” one of the host ID bits to divide the network 192.168.1.0 into two separate sub-networks. The subnet mask is now 25 bits (255.255.255.128 or /25).

The “borrowed” host ID bit can have a value of either 0 or 1, allowing two subnets; 192.168.1.0 /25 and 192.168.1.128 /25.

The following figure shows the company network after subnetting. There are now two sub-networks, **A** and **B**.

Figure 97 Subnetting Example: After Subnetting

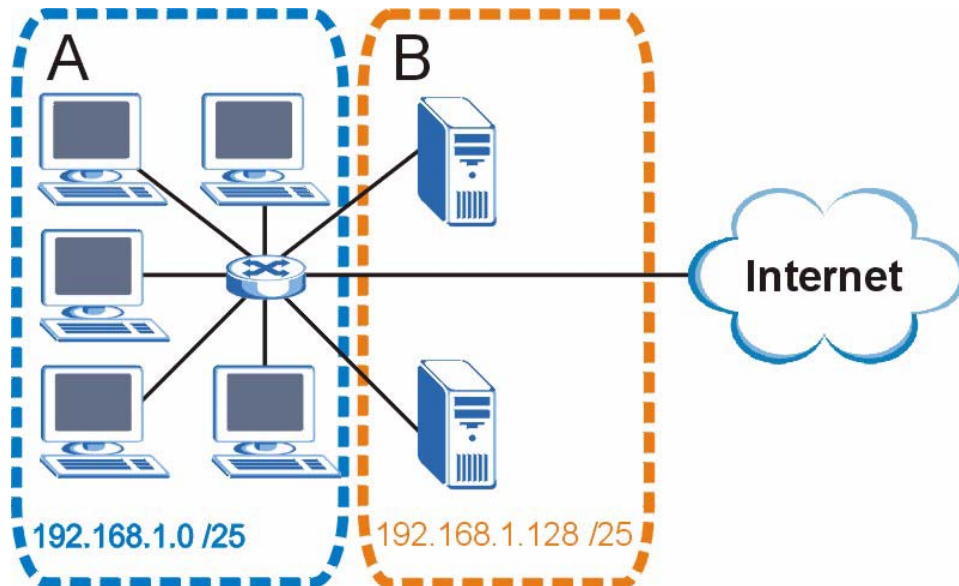

In a 25-bit subnet the host ID has 7 bits, so each sub-network has a maximum of $2^7 - 2$ or 126 possible hosts (a host ID of all zeroes is the subnet's address itself, all ones is the subnet's broadcast address).

192.168.1.0 with mask 255.255.255.128 is subnet **A** itself, and 192.168.1.127 with mask 255.255.255.128 is its broadcast address. Therefore, the lowest IP address that can be assigned to an actual host for subnet **A** is 192.168.1.1 and the highest is 192.168.1.126.

Similarly, the host ID range for subnet **B** is 192.168.1.129 to 192.168.1.254.

Example: Four Subnets

The previous example illustrated using a 25-bit subnet mask to divide a 24-bit address into two subnets. Similarly, to divide a 24-bit address into four subnets, you need to "borrow" two host ID bits to give four possible combinations (00, 01, 10 and 11). The subnet mask is 26 bits (11111111.11111111.11111111.11000000) or 255.255.255.192.

Each subnet contains 6 host ID bits, giving $2^6 - 2$ or 62 hosts for each subnet (a host ID of all zeroes is the subnet itself, all ones is the subnet's broadcast address).

Table 59 Subnet 1

IP/SUBNET MASK	NETWORK NUMBER	LAST OCTET BIT VALUE
IP Address (Decimal)	192.168.1.	0
IP Address (Binary)	11000000.10101000.00000001.	00000000
Subnet Mask (Binary)	11111111.11111111.11111111.	11000000
Subnet Address: 192.168.1.0	Lowest Host ID: 192.168.1.1	
Broadcast Address: 192.168.1.63	Highest Host ID: 192.168.1.62	

Table 60 Subnet 2

IP/SUBNET MASK	NETWORK NUMBER	LAST OCTET BIT VALUE
IP Address	192.168.1.	64
IP Address (Binary)	11000000.10101000.00000001.	01000000
Subnet Mask (Binary)	11111111.11111111.11111111.	11000000
Subnet Address: 192.168.1.64	Lowest Host ID: 192.168.1.65	
Broadcast Address: 192.168.1.127	Highest Host ID: 192.168.1.126	

Table 61 Subnet 3

IP/SUBNET MASK	NETWORK NUMBER	LAST OCTET BIT VALUE
IP Address	192.168.1.	128
IP Address (Binary)	11000000.10101000.00000001.	10000000
Subnet Mask (Binary)	11111111.11111111.11111111.	11000000
Subnet Address: 192.168.1.128	Lowest Host ID: 192.168.1.129	
Broadcast Address: 192.168.1.191	Highest Host ID: 192.168.1.190	

Table 62 Subnet 4

IP/SUBNET MASK	NETWORK NUMBER	LAST OCTET BIT VALUE
IP Address	192.168.1.	192
IP Address (Binary)	11000000.10101000.00000001. .	11000000
Subnet Mask (Binary)	11111111.11111111.11111111 .	11000000

Table 62 Subnet 4 (continued)

IP/SUBNET MASK	NETWORK NUMBER	LAST OCTET BIT VALUE
Subnet Address: 192.168.1.192	Lowest Host ID: 192.168.1.193	
Broadcast Address: 192.168.1.255	Highest Host ID: 192.168.1.254	

Example: Eight Subnets

Similarly, use a 27-bit mask to create eight subnets (000, 001, 010, 011, 100, 101, 110 and 111).

The following table shows IP address last octet values for each subnet.

Table 63 Eight Subnets

SUBNET	SUBNET ADDRESS	FIRST ADDRESS	LAST ADDRESS	BROADCAST ADDRESS
1	0	1	30	31
2	32	33	62	63
3	64	65	94	95
4	96	97	126	127
5	128	129	158	159
6	160	161	190	191
7	192	193	222	223
8	224	225	254	255

Subnet Planning

The following table is a summary for subnet planning on a network with a 24-bit network number.

Table 64 24-bit Network Number Subnet Planning

NO. "BORROWED" HOST BITS	SUBNET MASK	NO. SUBNETS	NO. HOSTS PER SUBNET
1	255.255.255.128 (/25)	2	126
2	255.255.255.192 (/26)	4	62
3	255.255.255.224 (/27)	8	30
4	255.255.255.240 (/28)	16	14
5	255.255.255.248 (/29)	32	6
6	255.255.255.252 (/30)	64	2
7	255.255.255.254 (/31)	128	1

The following table is a summary for subnet planning on a network with a 16-bit network number.

Table 65 16-bit Network Number Subnet Planning

NO. "BORROWED" HOST BITS	SUBNET MASK	NO. SUBNETS	NO. HOSTS PER SUBNET
1	255.255.128.0 (/17)	2	32766
2	255.255.192.0 (/18)	4	16382
3	255.255.224.0 (/19)	8	8190
4	255.255.240.0 (/20)	16	4094
5	255.255.248.0 (/21)	32	2046
6	255.255.252.0 (/22)	64	1022
7	255.255.254.0 (/23)	128	510
8	255.255.255.0 (/24)	256	254
9	255.255.255.128 (/25)	512	126
10	255.255.255.192 (/26)	1024	62
11	255.255.255.224 (/27)	2048	30
12	255.255.255.240 (/28)	4096	14
13	255.255.255.248 (/29)	8192	6
14	255.255.255.252 (/30)	16384	2
15	255.255.255.254 (/31)	32768	1

Configuring IP Addresses

Where you obtain your network number depends on your particular situation. If the ISP or your network administrator assigns you a block of registered IP addresses, follow their instructions in selecting the IP addresses and the subnet mask.

If the ISP did not explicitly give you an IP network number, then most likely you have a single user account and the ISP will assign you a dynamic IP address when the connection is established. If this is the case, it is recommended that you select a network number from 192.168.0.0 to 192.168.255.0. The Internet Assigned Number Authority (IANA) reserved this block of addresses specifically for private use; please do not use any other number unless you are told otherwise. You must also enable Network Address Translation (NAT) on the NBG-416N.

Once you have decided on the network number, pick an IP address for your NBG-416N that is easy to remember (for instance, 192.168.1.1) but make sure that no other device on your network is using that IP address.

The subnet mask specifies the network number portion of an IP address. Your NBG-416N will compute the subnet mask automatically based on the IP address

that you entered. You don't need to change the subnet mask computed by the NBG-416N unless you are instructed to do otherwise.

Private IP Addresses

Every machine on the Internet must have a unique address. If your networks are isolated from the Internet (running only between two branch offices, for example) you can assign any IP addresses to the hosts without problems. However, the Internet Assigned Numbers Authority (IANA) has reserved the following three blocks of IP addresses specifically for private networks:

- 10.0.0.0 — 10.255.255.255
- 172.16.0.0 — 172.31.255.255
- 192.168.0.0 — 192.168.255.255

You can obtain your IP address from the IANA, from an ISP, or it can be assigned from a private network. If you belong to a small organization and your Internet access is through an ISP, the ISP can provide you with the Internet addresses for your local networks. On the other hand, if you are part of a much larger organization, you should consult your network administrator for the appropriate IP addresses.

Regardless of your particular situation, do not create an arbitrary IP address; always follow the guidelines above. For more information on address assignment, please refer to RFC 1597, *Address Allocation for Private Internets* and RFC 1466, *Guidelines for Management of IP Address Space*.

Pop-up Windows, JavaScript and Java Permissions

In order to use the Web Configurator you need to allow:

- Web browser pop-up windows from your device.
- JavaScript (enabled by default).
- Java permissions (enabled by default).

Note: Internet Explorer 6 screens are used here. Screens for other Internet Explorer versions may vary.

Internet Explorer Pop-up Blockers

You may have to disable pop-up blocking to log into your device.

Either disable pop-up blocking (enabled by default in Windows XP SP (Service Pack) 2) or allow pop-up blocking and create an exception for your device's IP address.

Disable pop-up Blockers

- 1 In Internet Explorer, select **Tools, Pop-up Blocker** and then select **Turn Off Pop-up Blocker**.

Figure 98 Pop-up Blocker

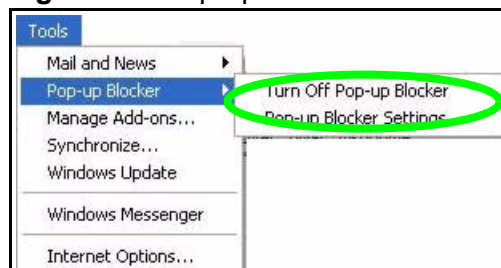

You can also check if pop-up blocking is disabled in the **Pop-up Blocker** section in the **Privacy** tab.

- 1 In Internet Explorer, select **Tools, Internet Options, Privacy**.
- 2 Clear the **Block pop-ups** check box in the **Pop-up Blocker** section of the screen. This disables any web pop-up blockers you may have enabled.

Figure 99 Internet Options: Privacy



- 3 Click **Apply** to save this setting.

Enable pop-up Blockers with Exceptions

Alternatively, if you only want to allow pop-up windows from your device, see the following steps.

- 1 In Internet Explorer, select **Tools, Internet Options** and then the **Privacy** tab.

- 2 Select **Settings...** to open the **Pop-up Blocker Settings** screen.

Figure 100 Internet Options: Privacy

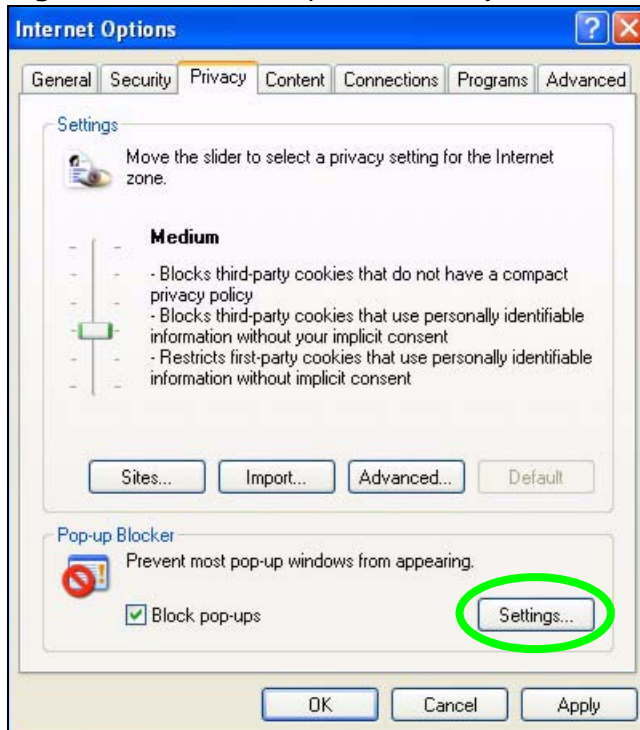

- 3 Type the IP address of your device (the web page that you do not want to have blocked) with the prefix "http://". For example, http://192.168.167.1.

- 4 Click **Add** to move the IP address to the list of **Allowed sites**.

Figure 101 Pop-up Blocker Settings

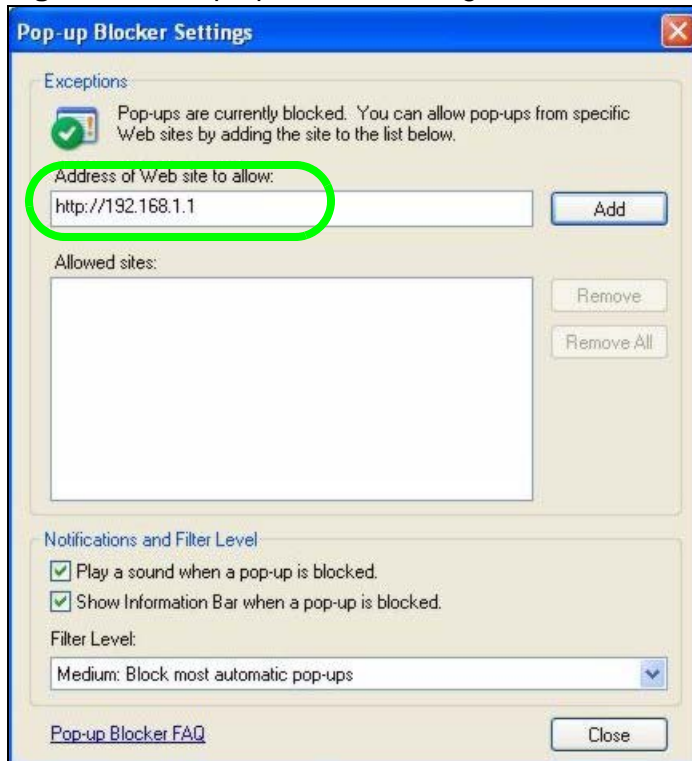

- 5 Click **Close** to return to the **Privacy** screen.
- 6 Click **Apply** to save this setting.

JavaScript

If pages of the Web Configurator do not display properly in Internet Explorer, check that JavaScript are allowed.

- 1 In Internet Explorer, click **Tools**, **Internet Options** and then the **Security** tab.

Figure 102 Internet Options: Security

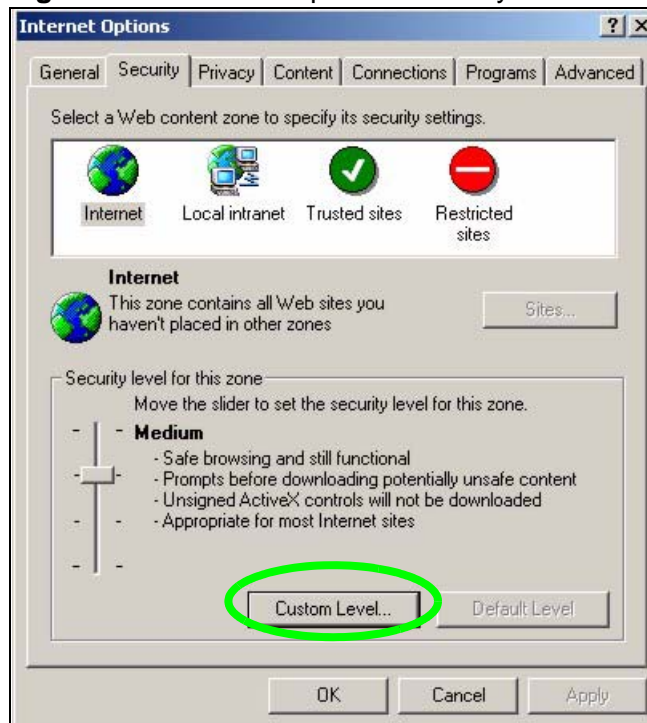

- 2 Click the **Custom Level...** button.
- 3 Scroll down to **Scripting**.
- 4 Under **Active scripting** make sure that **Enable** is selected (the default).
- 5 Under **Scripting of Java applets** make sure that **Enable** is selected (the default).

- 6 Click **OK** to close the window.

Figure 103 Security Settings - Java Scripting

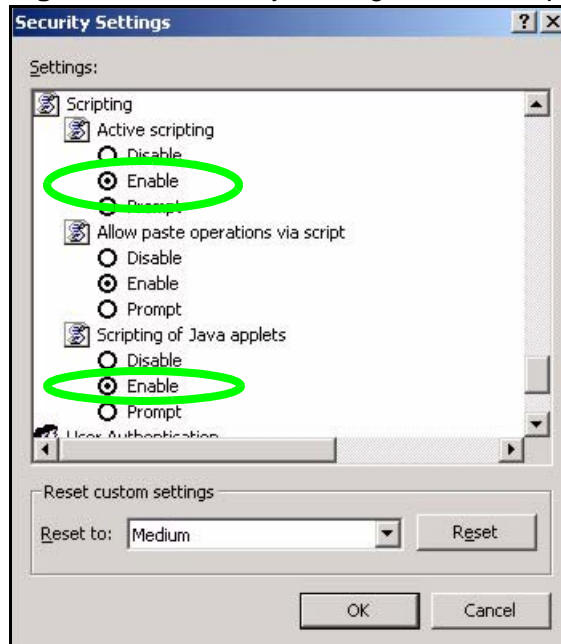

Java Permissions

- 1 From Internet Explorer, click **Tools, Internet Options** and then the **Security** tab.
- 2 Click the **Custom Level...** button.
- 3 Scroll down to **Microsoft VM**.
- 4 Under **Java permissions** make sure that a safety level is selected.

- 5 Click **OK** to close the window.

Figure 104 Security Settings - Java

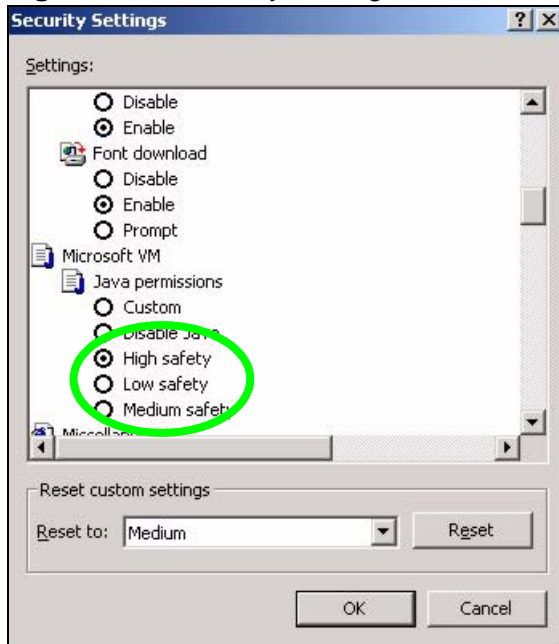

JAVA (Sun)

- 1 From Internet Explorer, click **Tools, Internet Options** and then the **Advanced** tab.
- 2 Make sure that **Use Java 2 for <applet>** under **Java (Sun)** is selected.

- 3 Click **OK** to close the window.

Figure 105 Java (Sun)

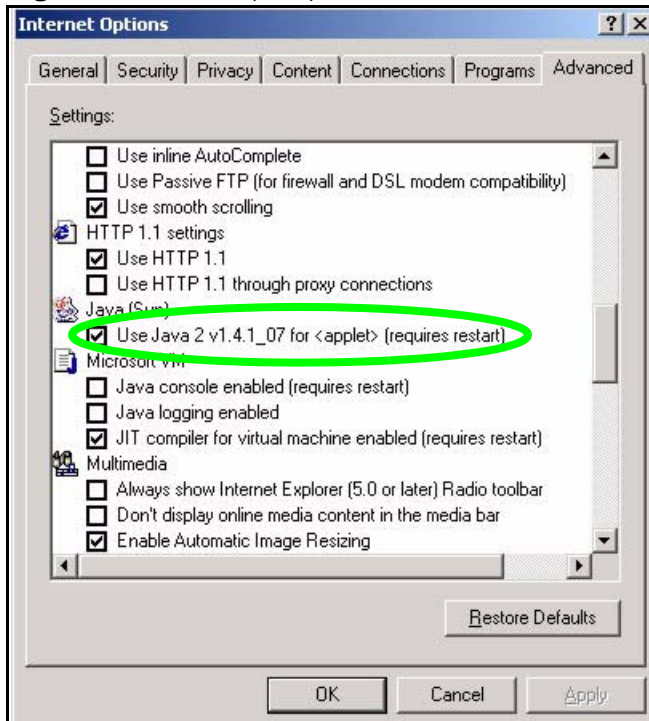

Setting up Your Computer's IP Address

All computers must have a 10M or 100M Ethernet adapter card and TCP/IP installed.

Windows 95/98/Me/NT/2000/XP, Macintosh OS 7 and later operating systems and all versions of UNIX/LINUX include the software components you need to install and use TCP/IP on your computer. Windows 3.1 requires the purchase of a third-party TCP/IP application package.

TCP/IP should already be installed on computers using Windows NT/2000/XP, Macintosh OS 7 and later operating systems.

After the appropriate TCP/IP components are installed, configure the TCP/IP settings in order to "communicate" with your network.

If you manually assign IP information instead of using dynamic assignment, make sure that your computers have IP addresses that place them in the same subnet as the Prestige's LAN port.

Windows 95/98/Me

Click **Start, Settings, Control Panel** and double-click the **Network** icon to open the **Network** window.

Figure 106 WIndows 95/98/Me: Network: Configuration

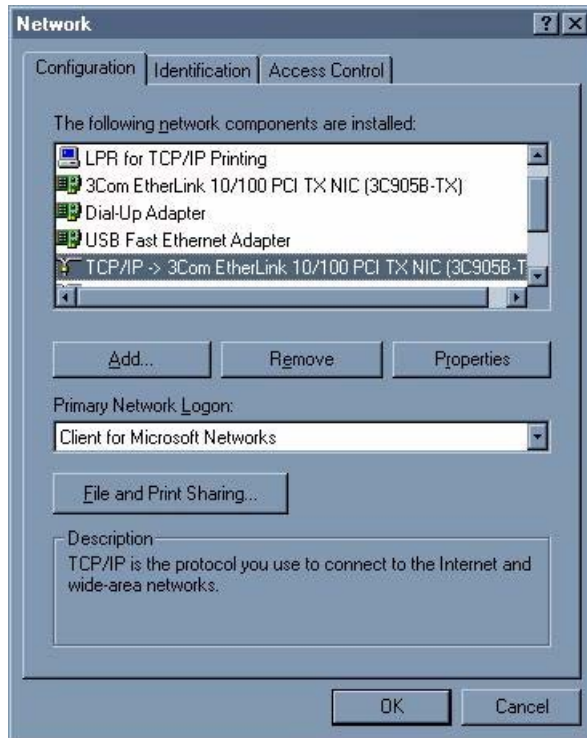

Installing Components

The **Network** window **Configuration** tab displays a list of installed components. You need a network adapter, the TCP/IP protocol and Client for Microsoft Networks.

If you need the adapter:

- 1 In the **Network** window, click **Add**.
- 2 Select **Adapter** and then click **Add**.
- 3 Select the manufacturer and model of your network adapter and then click **OK**.

If you need TCP/IP:

- 1 In the **Network** window, click **Add**.
- 2 Select **Protocol** and then click **Add**.

- 3 Click the **DNS** Configuration tab.
 - If you do not know your DNS information, select **Disable DNS**.
 - If you know your DNS information, select **Enable DNS** and type the information in the fields below (you may not need to fill them all in).

Figure 108 Windows 95/98/Me: TCP/IP Properties: DNS Configuration

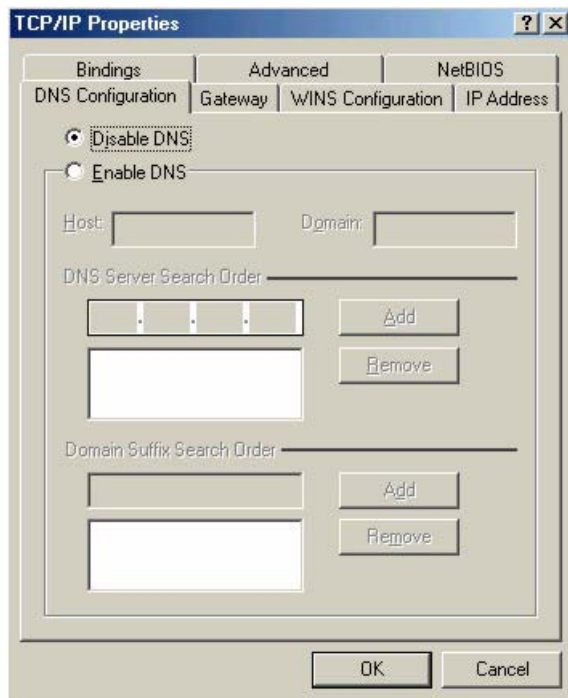

- 4 Click the **Gateway** tab.
 - If you do not know your gateway's IP address, remove previously installed gateways.
 - If you have a gateway IP address, type it in the **New gateway field** and click **Add**.
- 5 Click **OK** to save and close the **TCP/IP Properties** window.
- 6 Click **OK** to close the **Network** window. Insert the Windows CD if prompted.
- 7 Turn on your Prestige and restart your computer when prompted.

Verifying Settings

- 1 Click **Start** and then **Run**.
- 2 In the **Run** window, type "winipcfg" and then click **OK** to open the **IP Configuration** window.

- 3 Select your network adapter. You should see your computer's IP address, subnet mask and default gateway.

Windows 2000/NT/XP

The following example figures use the default Windows XP GUI theme.

- 1 Click **start** (**Start** in Windows 2000/NT), **Settings, Control Panel**.

Figure 109 Windows XP: Start Menu

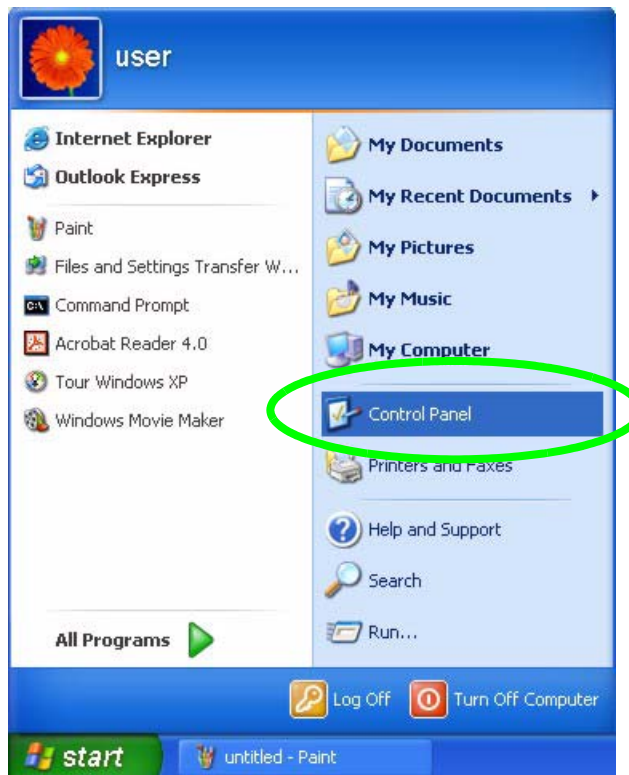

- 2 In the **Control Panel**, double-click **Network Connections (Network and Dial-up Connections)** in Windows 2000/NT).

Figure 110 Windows XP: Control Panel



- 3 Right-click **Local Area Connection** and then click **Properties**.

Figure 111 Windows XP: Control Panel: Network Connections: Properties

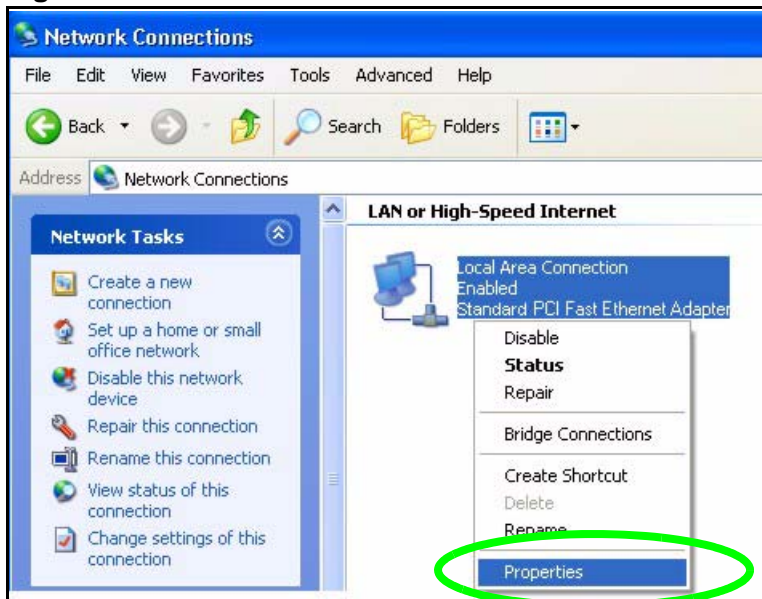

- 4 Select **Internet Protocol (TCP/IP)** (under the **General** tab in Win XP) and then click **Properties**.

Figure 112 Windows XP: Local Area Connection Properties

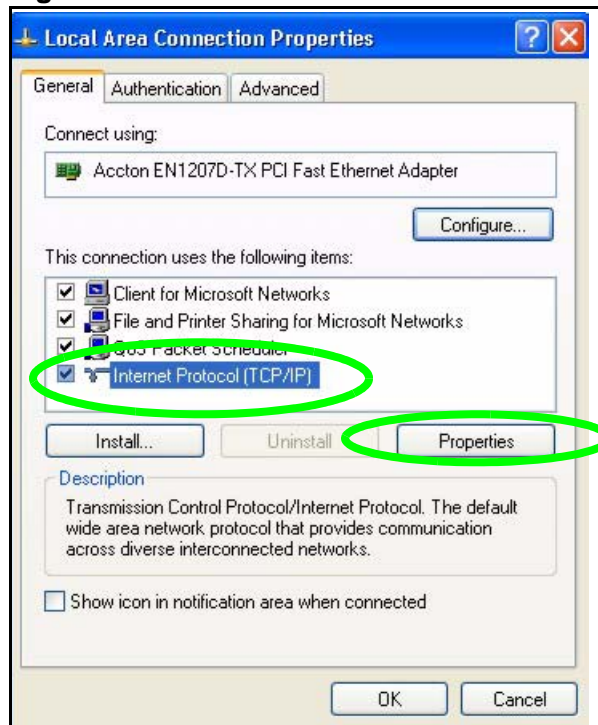

- 5 The **Internet Protocol TCP/IP Properties** window opens (the **General** tab in Windows XP).
 - If you have a dynamic IP address click **Obtain an IP address automatically**.
 - If you have a static IP address click **Use the following IP Address** and fill in the **IP address**, **Subnet mask**, and **Default gateway** fields.

- Click **Advanced**.

Figure 113 Windows XP: Internet Protocol (TCP/IP) Properties

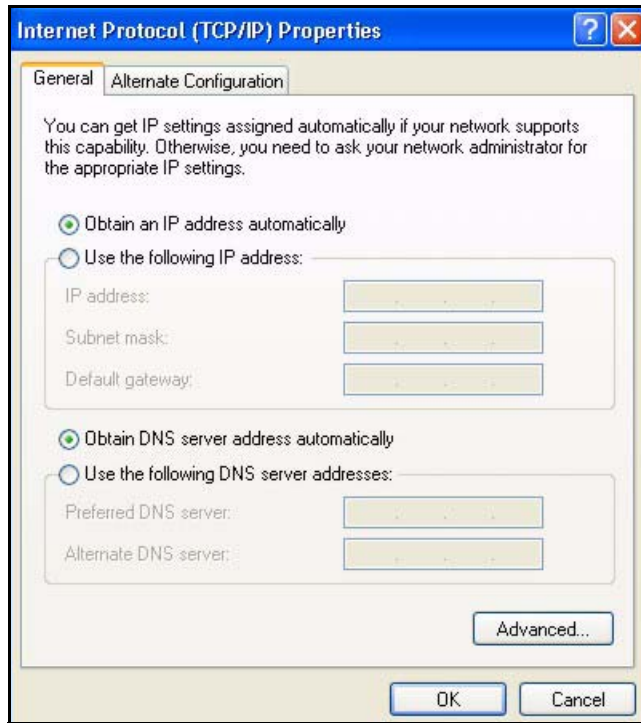

- 6 If you do not know your gateway's IP address, remove any previously installed gateways in the **IP Settings** tab and click **OK**.

Do one or more of the following if you want to configure additional IP addresses:

- In the **IP Settings** tab, in IP addresses, click **Add**.
- In **TCP/IP Address**, type an IP address in **IP address** and a subnet mask in **Subnet mask**, and then click **Add**.
- Repeat the above two steps for each IP address you want to add.
- Configure additional default gateways in the **IP Settings** tab by clicking **Add** in **Default gateways**.
- In **TCP/IP Gateway Address**, type the IP address of the default gateway in **Gateway**. To manually configure a default metric (the number of transmission hops), clear the **Automatic metric** check box and type a metric in **Metric**.
- Click **Add**.
- Repeat the previous three steps for each default gateway you want to add.

- Click **OK** when finished.

Figure 114 Windows XP: Advanced TCP/IP Properties

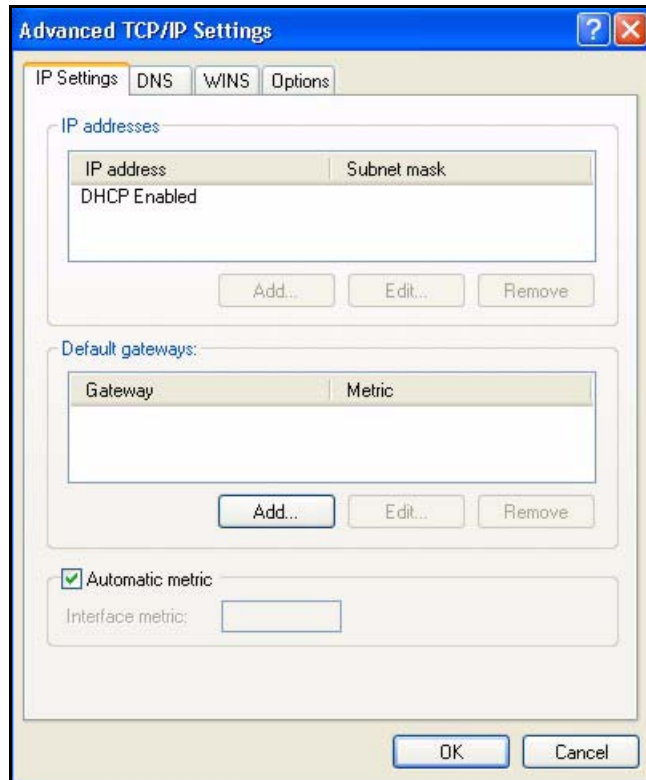

7 In the **Internet Protocol TCP/IP Properties** window (the **General** tab in Windows XP):

- Click **Obtain DNS server address automatically** if you do not know your DNS server IP address(es).
- If you know your DNS server IP address(es), click **Use the following DNS server addresses**, and type them in the **Preferred DNS server** and **Alternate DNS server** fields.

If you have previously configured DNS servers, click **Advanced** and then the **DNS** tab to order them.

Figure 115 Windows XP: Internet Protocol (TCP/IP) Properties

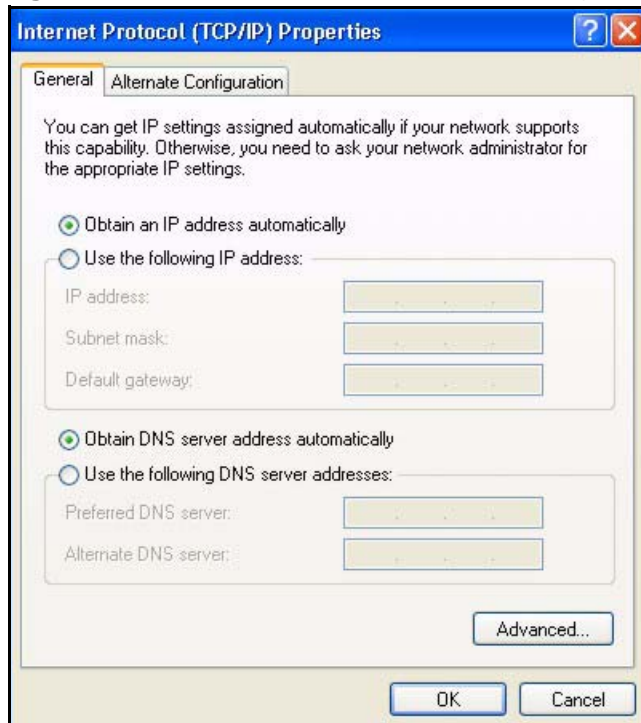

- 8 Click **OK** to close the **Internet Protocol (TCP/IP) Properties** window.
- 9 Click **Close** (**OK** in Windows 2000/NT) to close the **Local Area Connection Properties** window.
- 10 Close the **Network Connections** window (**Network and Dial-up Connections** in Windows 2000/NT).
- 11 Turn on your Prestige and restart your computer (if prompted).

Verifying Settings

- 1 Click **Start, All Programs, Accessories** and then **Command Prompt**.
- 2 In the **Command Prompt** window, type "ipconfig" and then press [ENTER]. You can also open **Network Connections**, right-click a network connection, click **Status** and then click the **Support** tab.

Macintosh OS 8/9

- 1 Click the **Apple** menu, **Control Panel** and double-click **TCP/IP** to open the **TCP/IP Control Panel**.

Figure 116 Macintosh OS 8/9: Apple Menu

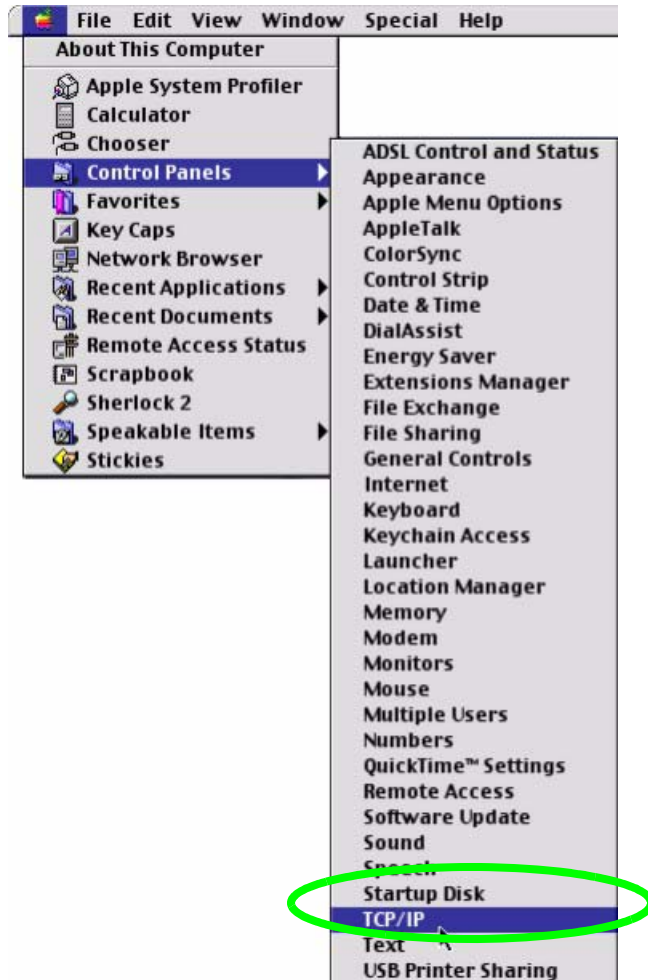

- 2 Select **Ethernet built-in** from the **Connect via** list.

Figure 117 Macintosh OS 8/9: TCP/IP

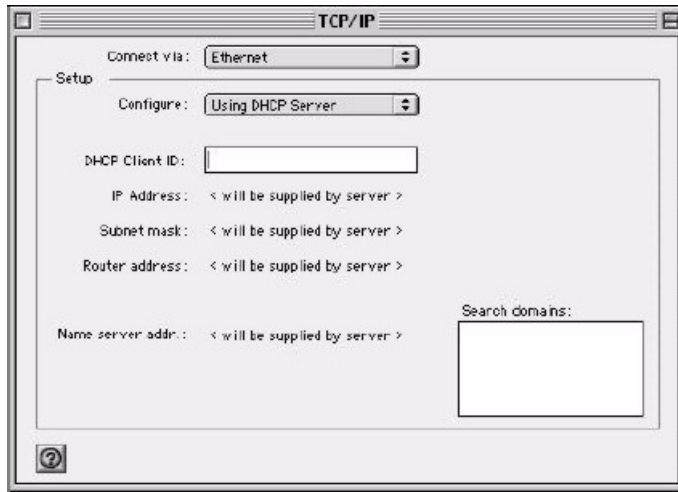

- 3 For dynamically assigned settings, select **Using DHCP Server** from the **Configure:** list.
- 4 For statically assigned settings, do the following:
 - From the **Configure** box, select **Manually**.
 - Type your IP address in the **IP Address** box.
 - Type your subnet mask in the **Subnet mask** box.
 - Type the IP address of your Prestige in the **Router address** box.
- 5 Close the **TCP/IP Control Panel**.
- 6 Click **Save** if prompted, to save changes to your configuration.
- 7 Turn on your Prestige and restart your computer (if prompted).

Verifying Settings

Check your TCP/IP properties in the **TCP/IP Control Panel** window.

Macintosh OS X

- 1 Click the **Apple** menu, and click **System Preferences** to open the **System Preferences** window.

Figure 118 Macintosh OS X: Apple Menu

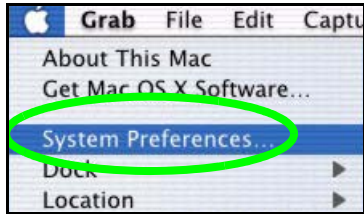

- 2 Click **Network** in the icon bar.
 - Select **Automatic** from the **Location** list.
 - Select **Built-in Ethernet** from the **Show** list.
 - Click the **TCP/IP** tab.
- 3 For dynamically assigned settings, select **Using DHCP** from the **Configure** list.

Figure 119 Macintosh OS X: Network

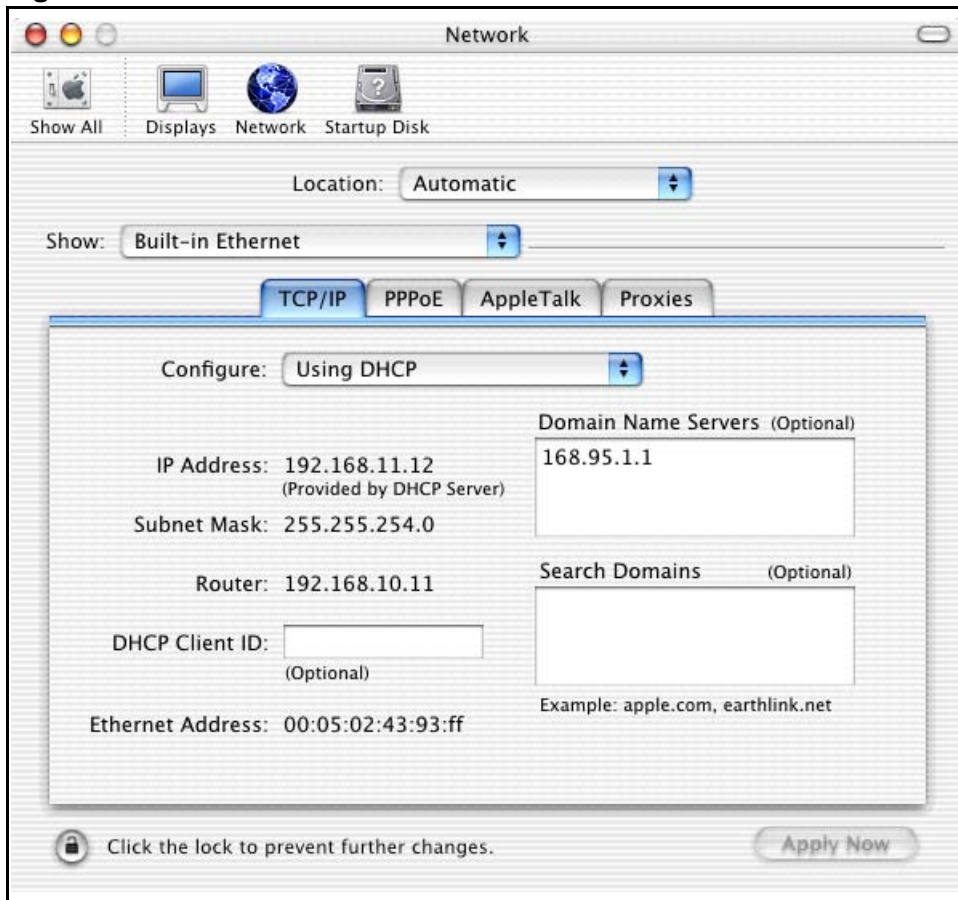

- 4 For statically assigned settings, do the following:
 - From the **Configure** box, select **Manually**.
 - Type your IP address in the **IP Address** box.
 - Type your subnet mask in the **Subnet mask** box.
 - Type the IP address of your Prestige in the **Router address** box.
- 5 Click **Apply Now** and close the window.
- 6 Turn on your Prestige and restart your computer (if prompted).

Verifying Settings

Check your TCP/IP properties in the **Network** window.

Linux

This section shows you how to configure your computer's TCP/IP settings in Red Hat Linux 9.0. Procedure, screens and file location may vary depending on your Linux distribution and release version.

Note: Make sure you are logged in as the root administrator.

Using the K Desktop Environment (KDE)

Follow the steps below to configure your computer IP address using the KDE.

- 1 Click the Red Hat button (located on the bottom left corner), select **System Setting** and click **Network**.

Figure 120 Red Hat 9.0: KDE: Network Configuration: Devices

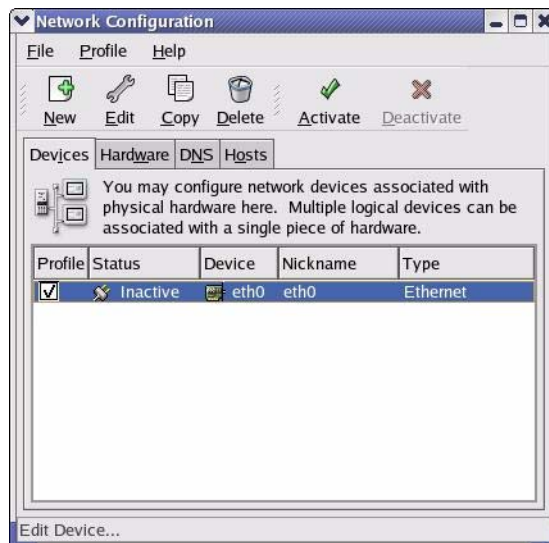

- 2 Double-click on the profile of the network card you wish to configure. The **Ethernet Device General** screen displays as shown.

Figure 121 Red Hat 9.0: KDE: Ethernet Device: General



- If you have a dynamic IP address click **Automatically obtain IP address settings with** and select **dhcp** from the drop down list.
 - If you have a static IP address click **Statically set IP Addresses** and fill in the **Address**, **Subnet mask**, and **Default Gateway Address** fields.
- 3 Click **OK** to save the changes and close the **Ethernet Device General** screen.
 - 4 If you know your DNS server IP address(es), click the **DNS** tab in the **Network Configuration** screen. Enter the DNS server information in the fields provided.

Figure 122 Red Hat 9.0: KDE: Network Configuration: DNS

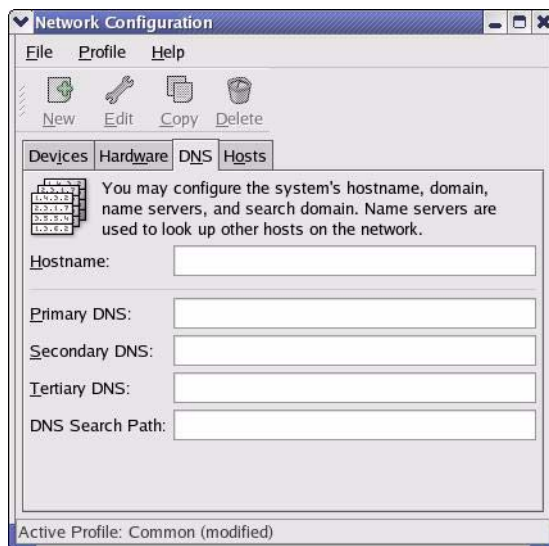

- 5 Click the **Devices** tab.
- 6 Click the **Activate** button to apply the changes. The following screen displays. Click **Yes to save the changes in all screens**.

Figure 123 Red Hat 9.0: KDE: Network Configuration: Activate

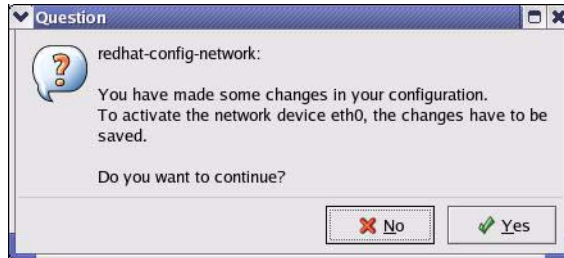

- 7 After the network card restart process is complete, make sure the **Status** is **Active** in the **Network Configuration** screen.

Using Configuration Files

Follow the steps below to edit the network configuration files and set your computer IP address.

- 1 Assuming that you have only one network card on the computer, locate the `ifconfig-eth0` configuration file (where `eth0` is the name of the Ethernet card). Open the configuration file with any plain text editor.
 - If you have a dynamic IP address, enter `dhcp` in the `BOOTPROTO=` field. The following figure shows an example.

Figure 124 Red Hat 9.0: Dynamic IP Address Setting in `ifconfig-eth0`

```
DEVICE=eth0
ONBOOT=yes
BOOTPROTO=dhcp
USERCTL=no
PEERDNS=yes
TYPE=Ethernet
```

- If you have a static IP address, enter **static** in the `BOOTPROTO=` field. Type `IPADDR=` followed by the IP address (in dotted decimal notation) and type `NETMASK=` followed by the subnet mask. The following example shows an example where the static IP address is 192.168.1.10 and the subnet mask is 255.255.255.0.

Figure 125 Red Hat 9.0: Static IP Address Setting in `ifconfig-eth0`

```
DEVICE=eth0
ONBOOT=yes
BOOTPROTO=static
IPADDR=192.168.1.10
NETMASK=255.255.255.0
USERCTL=no
PEERDNS=yes
TYPE=Ethernet
```

- 2 If you know your DNS server IP address(es), enter the DNS server information in the `resolv.conf` file in the `/etc` directory. The following figure shows an example where two DNS server IP addresses are specified.

Figure 126 Red Hat 9.0: DNS Settings in `resolv.conf`

```
nameserver 172.23.5.1
nameserver 172.23.5.2
```

- 3 After you edit and save the configuration files, you must restart the network card. Enter `./network restart` in the `/etc/rc.d/init.d` directory. The following figure shows an example.

Figure 127 Red Hat 9.0: Restart Ethernet Card

```
[root@localhost init.d]# network restart

Shutting down interface eth0:           [OK]
Shutting down loopback interface:      [OK]
Setting network parameters:           [OK]
Bringing up loopback interface:        [OK]
Bringing up interface eth0:           [OK]
```

21.0.1 Verifying Settings

Enter `ifconfig` in a terminal screen to check your TCP/IP properties.

Figure 128 Red Hat 9.0: Checking TCP/IP Properties

```
[root@localhost]# ifconfig
eth0      Link encap:Ethernet HWaddr 00:50:BA:72:5B:44
          inet addr:172.23.19.129 Bcast:172.23.19.255 Mask:255.255.255.0
          UP BROADCAST RUNNING MULTICAST MTU:1500 Metric:1
          RX packets:717 errors:0 dropped:0 overruns:0 frame:0
          TX packets:13 errors:0 dropped:0 overruns:0 carrier:0
          collisions:0 txqueuelen:100
          RX bytes:730412 (713.2 Kb) TX bytes:1570 (1.5 Kb)
          Interrupt:10 Base address:0x1000
[root@localhost]#
```

Wireless LANs

Wireless LAN Topologies

This section discusses ad-hoc and infrastructure wireless LAN topologies.

Ad-hoc Wireless LAN Configuration

The simplest WLAN configuration is an independent (Ad-hoc) WLAN that connects a set of computers with wireless stations (A, B, C). Any time two or more wireless adapters are within range of each other, they can set up an independent network, which is commonly referred to as an Ad-hoc network or Independent Basic Service Set (IBSS). The following diagram shows an example of notebook computers using wireless adapters to form an Ad-hoc wireless LAN.

Figure 129 Peer-to-Peer Communication in an Ad-hoc Network

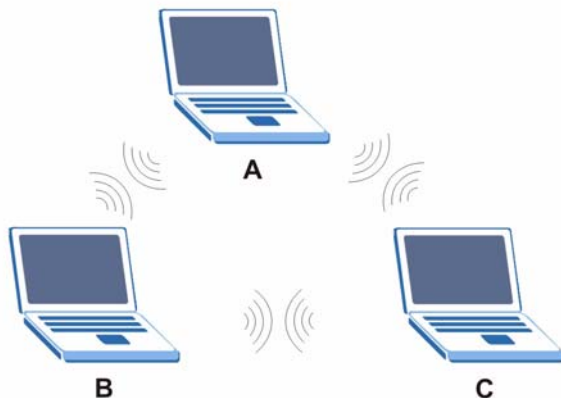

BSS

A Basic Service Set (BSS) exists when all communications between wireless stations or between a wireless station and a wired network client go through one access point (AP).

Intra-BSS traffic is traffic between wireless stations in the BSS. When Intra-BSS is enabled, wireless station A and B can access the wired network and communicate

with each other. When Intra-BSS is disabled, wireless station A and B can still access the wired network but cannot communicate with each other.

Figure 130 Basic Service Set

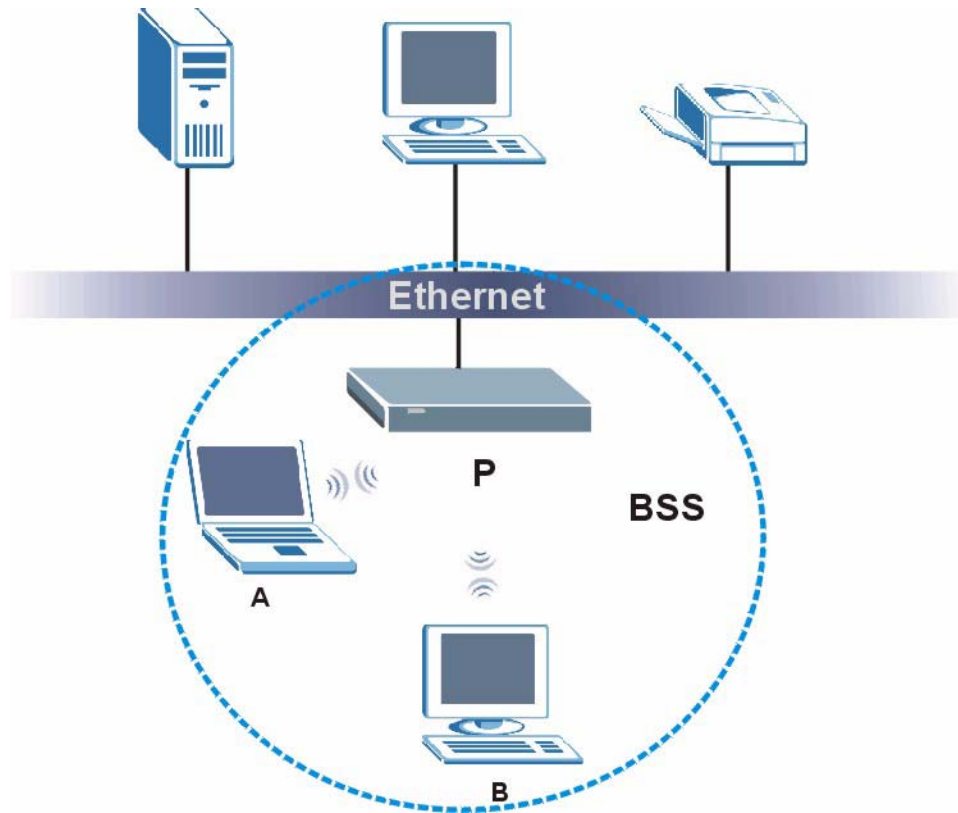

ESS

An Extended Service Set (ESS) consists of a series of overlapping BSSs, each containing an access point, with each access point connected together by a wired network. This wired connection between APs is called a Distribution System (DS).

This type of wireless LAN topology is called an Infrastructure WLAN. The Access Points not only provide communication with the wired network but also mediate wireless network traffic in the immediate neighborhood.

An ESSID (ESS IDentification) uniquely identifies each ESS. All access points and their associated wireless stations within the same ESS must have the same ESSID in order to communicate.

Figure 131 Infrastructure WLAN

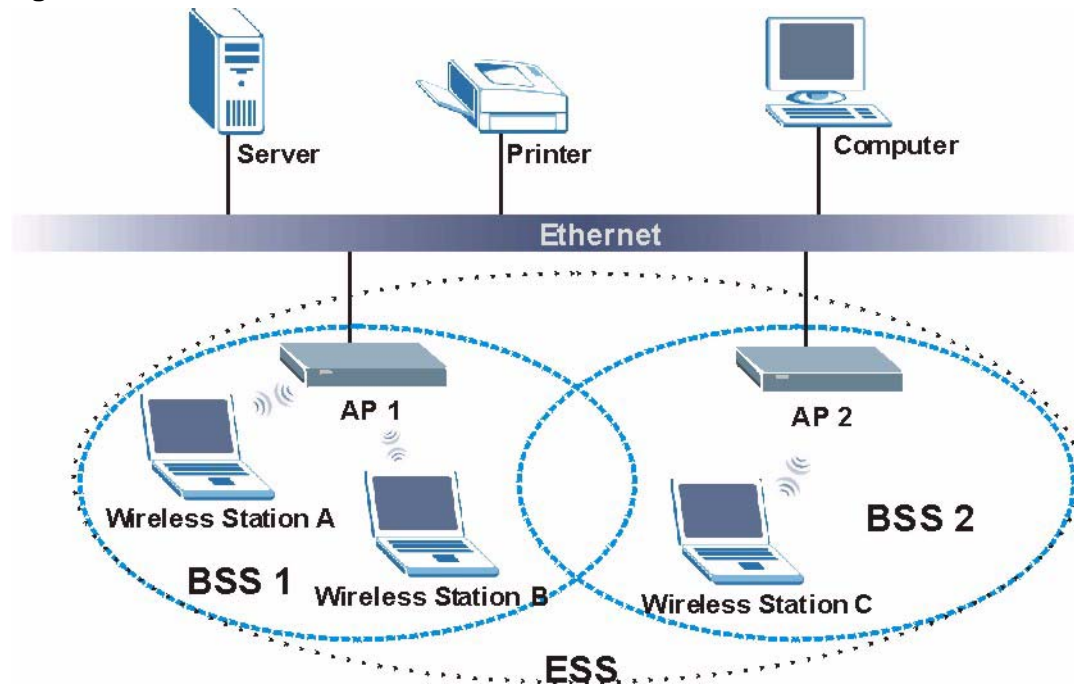

Channel

A channel is the radio frequency(ies) used by IEEE 802.11a/b/g wireless devices. Channels available depend on your geographical area. You may have a choice of channels (for your region) so you should use a different channel than an adjacent AP (access point) to reduce interference. Interference occurs when radio signals from different access points overlap causing interference and degrading performance.

Adjacent channels partially overlap however. To avoid interference due to overlap, your AP should be on a channel at least five channels away from a channel that an adjacent AP is using. For example, if your region has 11 channels and an adjacent AP is using channel 1, then you need to select a channel between 6 or 11.

RTS/CTS

A hidden node occurs when two stations are within range of the same access point, but are not within range of each other. The following figure illustrates a hidden node. Both stations (STA) are within range of the access point (AP) or

wireless gateway, but out-of-range of each other, so they cannot "hear" each other, that is they do not know if the channel is currently being used. Therefore, they are considered hidden from each other.

Figure 132 RTS/CTS

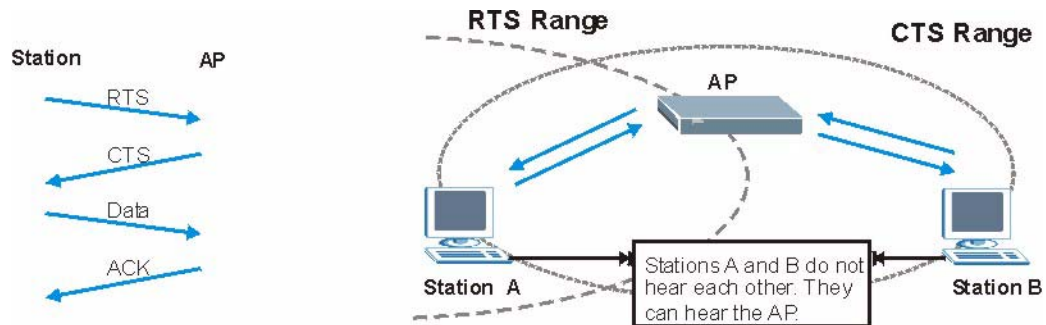

When station A sends data to the AP, it might not know that the station B is already using the channel. If these two stations send data at the same time, collisions may occur when both sets of data arrive at the AP at the same time, resulting in a loss of messages for both stations.

RTS/CTS is designed to prevent collisions due to hidden nodes. An **RTS/CTS** defines the biggest size data frame you can send before an RTS (Request To Send)/CTS (Clear to Send) handshake is invoked.

When a data frame exceeds the **RTS/CTS** value you set (between 0 to 2432 bytes), the station that wants to transmit this frame must first send an RTS (Request To Send) message to the AP for permission to send it. The AP then responds with a CTS (Clear to Send) message to all other stations within its range to notify them to defer their transmission. It also reserves and confirms with the requesting station the time frame for the requested transmission.

Stations can send frames smaller than the specified **RTS/CTS** directly to the AP without the RTS (Request To Send)/CTS (Clear to Send) handshake.

You should only configure **RTS/CTS** if the possibility of hidden nodes exists on your network and the "cost" of resending large frames is more than the extra network overhead involved in the RTS (Request To Send)/CTS (Clear to Send) handshake.

If the **RTS/CTS** value is greater than the **Fragmentation Threshold** value (see next), then the RTS (Request To Send)/CTS (Clear to Send) handshake will never occur as data frames will be fragmented before they reach **RTS/CTS** size.

Note: Enabling the RTS Threshold causes redundant network overhead that could negatively affect the throughput performance instead of providing a remedy.

Fragmentation Threshold

A **Fragmentation Threshold** is the maximum data fragment size (between 256 and 2432 bytes) that can be sent in the wireless network before the AP will fragment the packet into smaller data frames.

A large **Fragmentation Threshold** is recommended for networks not prone to interference while you should set a smaller threshold for busy networks or networks that are prone to interference.

If the **Fragmentation Threshold** value is smaller than the **RTS/CTS** value (see previously) you set then the RTS (Request To Send)/CTS (Clear to Send) handshake will never occur as data frames will be fragmented before they reach **RTS/CTS** size.

Preamble Type

A preamble is used to synchronize the transmission timing in your wireless network. There are two preamble modes: **Long** and **Short**.

Short preamble takes less time to process and minimizes overhead, so it should be used in a good wireless network environment when all wireless stations support it.

Select **Long** if you have a 'noisy' network or are unsure of what preamble mode your wireless stations support as all IEEE 802.11b compliant wireless adapters must support long preamble. However, not all wireless adapters support short preamble. Use long preamble if you are unsure what preamble mode the wireless adapters support, to ensure interpretability between the AP and the wireless stations and to provide more reliable communication in 'noisy' networks.

Select **Dynamic** to have the AP automatically use short preamble when all wireless stations support it, otherwise the AP uses long preamble.

Note: The AP and the wireless stations **MUST** use the same preamble mode in order to communicate.

IEEE 802.11g Wireless LAN

IEEE 802.11g is fully compatible with the IEEE 802.11b standard. This means an IEEE 802.11b adapter can interface directly with an IEEE 802.11g access point (and vice versa) at 11 Mbps or lower depending on range. IEEE 802.11g has

several intermediate rate steps between the maximum and minimum data rates. The IEEE 802.11g data rate and modulation are as follows:

Table 66 IEEE 802.11g

DATA RATE (MBPS)	MODULATION
1	DBPSK (Differential Binary Phase Shift Keyed)
2	DQPSK (Differential Quadrature Phase Shift Keying)
5.5 / 11	CCK (Complementary Code Keying)
6/9/12/18/24/36/ 48/54	OFDM (Orthogonal Frequency Division Multiplexing)

IEEE 802.1x

In June 2001, the IEEE 802.1x standard was designed to extend the features of IEEE 802.11 to support extended authentication as well as providing additional accounting and control features. It is supported by Windows XP and a number of network devices. Some advantages of IEEE 802.1x are:

- User based identification that allows for roaming.
- Support for RADIUS (Remote Authentication Dial In User Service, RFC 2138, 2139) for centralized user profile and accounting management on a network RADIUS server.
- Support for EAP (Extensible Authentication Protocol, RFC 2486) that allows additional authentication methods to be deployed with no changes to the access point or the wireless stations.

RADIUS

RADIUS is based on a client-server model that supports authentication, authorization and accounting. The access point is the client and the server is the RADIUS server. The RADIUS server handles the following tasks:

- Authentication
Determines the identity of the users.
- Authorization
Determines the network services available to authenticated users once they are connected to the network.
- Accounting
Keeps track of the client's network activity.

RADIUS is a simple package exchange in which your AP acts as a message relay between the wireless station and the network RADIUS server.

Types of RADIUS Messages

The following types of RADIUS messages are exchanged between the access point and the RADIUS server for user authentication:

- **Access-Request**
Sent by an access point requesting authentication.
- **Access-Reject**
Sent by a RADIUS server rejecting access.
- **Access-Accept**
Sent by a RADIUS server allowing access.
- **Access-Challenge**
Sent by a RADIUS server requesting more information in order to allow access. The access point sends a proper response from the user and then sends another Access-Request message.

The following types of RADIUS messages are exchanged between the access point and the RADIUS server for user accounting:

- **Accounting-Request**
Sent by the access point requesting accounting.
- **Accounting-Response**
Sent by the RADIUS server to indicate that it has started or stopped accounting.

In order to ensure network security, the access point and the RADIUS server use a shared secret key, which is a password, they both know. The key is not sent over the network. In addition to the shared key, password information exchanged is also encrypted to protect the network from unauthorized access.

Types of Authentication

This appendix discusses some popular authentication types: **EAP-MD5**, **EAP-TLS**, **EAP-TTLS**, **PEAP** and **LEAP**.

The type of authentication you use depends on the RADIUS server or the AP. Consult your network administrator for more information.

EAP-MD5 (Message-Digest Algorithm 5)

MD5 authentication is the simplest one-way authentication method. The authentication server sends a challenge to the wireless station. The wireless station 'proves' that it knows the password by encrypting the password with the challenge and sends back the information. Password is not sent in plain text.

However, MD5 authentication has some weaknesses. Since the authentication server needs to get the plaintext passwords, the passwords must be stored. Thus someone other than the authentication server may access the password file. In addition, it is possible to impersonate an authentication server as MD5 authentication method does not perform mutual authentication. Finally, MD5 authentication method does not support data encryption with dynamic session key. You must configure WEP encryption keys for data encryption.

EAP-TLS (Transport Layer Security)

With EAP-TLS, digital certifications are needed by both the server and the wireless stations for mutual authentication. The server presents a certificate to the client. After validating the identity of the server, the client sends a different certificate to the server. The exchange of certificates is done in the open before a secured tunnel is created. This makes user identity vulnerable to passive attacks. A digital certificate is an electronic ID card that authenticates the sender's identity. However, to implement EAP-TLS, you need a Certificate Authority (CA) to handle certificates, which imposes a management overhead.

EAP-TTLS (Tunneled Transport Layer Service)

EAP-TTLS is an extension of the EAP-TLS authentication that uses certificates for only the server-side authentications to establish a secure connection. Client authentication is then done by sending username and password through the secure connection, thus client identity is protected. For client authentication, EAP-TTLS supports EAP methods and legacy authentication methods such as PAP, CHAP, MS-CHAP and MS-CHAP v2.

PEAP (Protected EAP)

Like EAP-TTLS, server-side certificate authentication is used to establish a secure connection, then use simple username and password methods through the secured connection to authenticate the clients, thus hiding client identity. However, PEAP only supports EAP methods, such as EAP-MD5, EAP-MSCHAPv2 and EAP-GTC (EAP-Generic Token Card), for client authentication. EAP-GTC is implemented only by Cisco.

LEAP

LEAP (Lightweight Extensible Authentication Protocol) is a Cisco implementation of IEEE 802.1x.

Dynamic WEP Key Exchange

The AP maps a unique key that is generated with the RADIUS server. This key expires when the wireless connection times out, disconnects or reauthentication times out. A new WEP key is generated each time reauthentication is performed.

If this feature is enabled, it is not necessary to configure a default encryption key in the Wireless screen. You may still configure and store keys here, but they will not be used while Dynamic WEP is enabled.

Note: EAP-MD5 cannot be used with dynamic WEP key exchange

For added security, certificate-based authentications (EAP-TLS, EAP-TTLS and PEAP) use dynamic keys for data encryption. They are often deployed in corporate environments, but for public deployment, a simple user name and password pair is more practical. The following table is a comparison of the features of authentication types.

Table 67 Comparison of EAP Authentication Types

	EAP-MD5	EAP-TLS	EAP-TTLS	PEAP	LEAP
Mutual Authentication	No	Yes	Yes	Yes	Yes
Certificate – Client	No	Yes	Optional	Optional	No
Certificate – Server	No	Yes	Yes	Yes	No
Dynamic Key Exchange	No	Yes	Yes	Yes	Yes
Credential Integrity	None	Strong	Strong	Strong	Moderate
Deployment Difficulty	Easy	Hard	Moderate	Moderate	Moderate
Client Identity Protection	No	No	Yes	Yes	No

WPA(2)

Wi-Fi Protected Access (WPA) is a subset of the IEEE 802.11i standard. WPA2 (IEEE 802.11i) is a wireless security standard that defines stronger encryption, authentication and key management than WPA.

Key differences between WPA(2) and WEP are improved data encryption and user authentication.

Encryption

Both WPA and WPA2 improve data encryption by using Temporal Key Integrity Protocol (TKIP), Message Integrity Check (MIC) and IEEE 802.1x. In addition to TKIP, WPA2 also uses Advanced Encryption Standard (AES) in the Counter mode with Cipher block chaining Message authentication code Protocol (CCMP) to offer stronger encryption.

Temporal Key Integrity Protocol (TKIP) uses 128-bit keys that are dynamically generated and distributed by the authentication server. It includes a per-packet key mixing function, a Message Integrity Check (MIC) named Michael, an extended initialization vector (IV) with sequencing rules, and a re-keying mechanism.

TKIP regularly changes and rotates the encryption keys so that the same encryption key is never used twice. The RADIUS server distributes a Pairwise Master Key (PMK) key to the AP that then sets up a key hierarchy and management system, using the pair-wise key to dynamically generate unique data encryption keys to encrypt every data packet that is wirelessly communicated between the AP and the wireless clients. This all happens in the background automatically.

WPA2 AES (Advanced Encryption Standard) is a block cipher that uses a 256-bit mathematical algorithm called Rijndael.

The Message Integrity Check (MIC) is designed to prevent an attacker from capturing data packets, altering them and resending them. The MIC provides a strong mathematical function in which the receiver and the transmitter each compute and then compare the MIC. If they do not match, it is assumed that the data has been tampered with and the packet is dropped.

By generating unique data encryption keys for every data packet and by creating an integrity checking mechanism (MIC), TKIP makes it much more difficult to decode data on a Wi-Fi network than WEP, making it difficult for an intruder to break into the network.

The encryption mechanisms used for WPA and WPA-PSK are the same. The only difference between the two is that WPA-PSK uses a simple common password, instead of user-specific credentials. The common-password approach makes WPA-PSK susceptible to brute-force password-guessing attacks but it's still an improvement over WEP as it employs an easier-to-use, consistent, single, alphanumeric password.

User Authentication

WPA or WPA2 applies IEEE 802.1x and Extensible Authentication Protocol (EAP) to authenticate wireless clients using an external RADIUS database.

If both an AP and the wireless clients support WPA2 and you have an external RADIUS server, use WPA2 for stronger data encryption. If you don't have an external RADIUS server, you should use WPA2 -PSK (WPA2 -Pre-Shared Key) that only requires a single (identical) password entered into each access point, wireless gateway and wireless client. As long as the passwords match, a wireless client will be granted access to a WLAN.

If the AP or the wireless clients do not support WPA2, just use WPA or WPA-PSK depending on whether you have an external RADIUS server or not.

Select WEP only when the AP and/or wireless clients do not support WPA or WPA2. WEP is less secure than WPA or WPA2.

21.0.2 WPA(2)-PSK Application Example

A WPA(2)-PSK application looks as follows.

- 1 First enter identical passwords into the AP and all wireless clients. The Pre-Shared Key (PSK) must consist of between 8 and 63 ASCII characters (including spaces and symbols).
- 2 The AP checks each wireless client's password and (only) allows it to join the network if the password matches.
- 3 The AP derives and distributes keys to the wireless clients.
- 4 The AP and wireless clients use the TKIP or AES encryption process to encrypt data exchanged between them.

Figure 133 WPA(2)-PSK Authentication

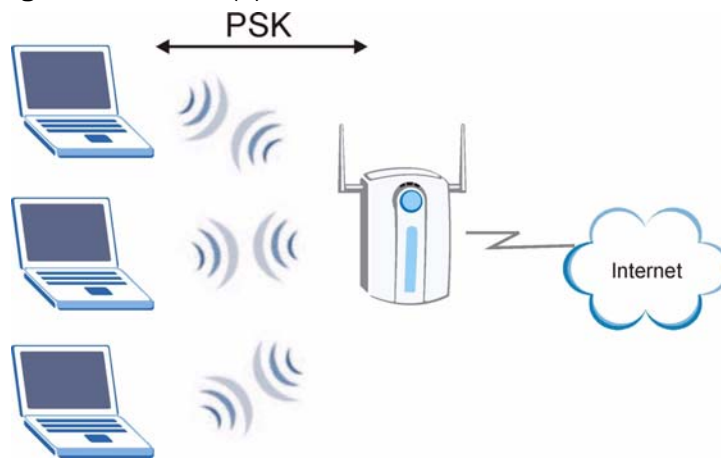

21.0.3 WPA(2) with RADIUS Application Example

You need the IP address of the RADIUS server, its port number (default is 1812), and the RADIUS shared secret. A WPA(2) application example with an external RADIUS server looks as follows. "A" is the RADIUS server. "DS" is the distribution system.

- 1 The AP passes the wireless client's authentication request to the RADIUS server.
- 2 The RADIUS server then checks the user's identification against its database and grants or denies network access accordingly.
- 3 The RADIUS server distributes a Pairwise Master Key (PMK) key to the AP that then sets up a key hierarchy and management system, using the pair-wise key to dynamically generate unique data encryption keys to encrypt every data packet that is wirelessly communicated between the AP and the wireless clients.

Security Parameters Summary

Refer to this table to see what other security parameters you should configure for each Authentication Method/ key management protocol type. MAC address filters are not dependent on how you configure these security features.

Table 68 Wireless Security Relational Matrix

AUTHENTICATION METHOD/ KEY MANAGEMENT PROTOCOL	ENCRYPTION METHOD	ENTER MANUAL KEY	IEEE 802.1X
Open	None	No	Disable
			Enable without Dynamic WEP Key
Open	WEP	No	Enable with Dynamic WEP Key
		Yes	Enable without Dynamic WEP Key
		Yes	Disable
Shared	WEP	No	Enable with Dynamic WEP Key
		Yes	Enable without Dynamic WEP Key
		Yes	Disable
WPA	TKIP	No	Enable
WPA-PSK	TKIP	Yes	Enable
WPA2	AES	No	Enable
WPA2-PSK	AES	Yes	Enable

Services

The following table lists some commonly-used services and their associated protocols and port numbers.

- **Name:** This is a short, descriptive name for the service. You can use this one or create a different one, if you like.
- **Protocol:** This is the type of IP protocol used by the service. If this is **TCP/UDP**, then the service uses the same port number with TCP and UDP. If this is **User-Defined**, the **Port(s)** is the IP protocol number, not the port number.
- **Port(s):** This value depends on the **Protocol**.
 - If the **Protocol** is **TCP, UDP, or TCP/UDP**, this is the IP port number.
 - If the **Protocol** is **USER**, this is the IP protocol number.
- **Description:** This is a brief explanation of the applications that use this service or the situations in which this service is used.

Table 69 Examples of Services

NAME	PROTOCOL	PORT(S)	DESCRIPTION
AH (IPSEC_TUNNEL)	User-Defined	51	The IPSEC AH (Authentication Header) tunneling protocol uses this service.
AIM	TCP	5190	AOL's Internet Messenger service.
AUTH	TCP	113	Authentication protocol used by some servers.
BGP	TCP	179	Border Gateway Protocol.
BOOTP_CLIENT	UDP	68	DHCP Client.
BOOTP_SERVER	UDP	67	DHCP Server.
CU-SEEME	TCP/UDP TCP/UDP	7648 24032	A popular videoconferencing solution from White Pines Software.
DNS	TCP/UDP	53	Domain Name Server, a service that matches web names (e.g. www.zyxel.com) to IP numbers.
ESP (IPSEC_TUNNEL)	User-Defined	50	The IPSEC ESP (Encapsulation Security Protocol) tunneling protocol uses this service.
FINGER	TCP	79	Finger is a UNIX or Internet related command that can be used to find out if a user is logged on.

Table 69 Examples of Services (continued)

NAME	PROTOCOL	PORT(S)	DESCRIPTION
FTP	TCP	20	File Transfer Program, a program to enable fast transfer of files, including large files that may not be possible by e-mail.
	TCP	21	
H.323	TCP	1720	NetMeeting uses this protocol.
HTTP	TCP	80	Hyper Text Transfer Protocol - a client/server protocol for the world wide web.
HTTPS	TCP	443	HTTPS is a secured http session often used in e-commerce.
ICMP	User-Defined	1	Internet Control Message Protocol is often used for diagnostic purposes.
ICQ	UDP	4000	This is a popular Internet chat program.
IGMP (MULTICAST)	User-Defined	2	Internet Group Multicast Protocol is used when sending packets to a specific group of hosts.
IKE	UDP	500	The Internet Key Exchange algorithm is used for key distribution and management.
IMAP4	TCP	143	The Internet Message Access Protocol is used for e-mail.
IMAP4S	TCP	993	This is a more secure version of IMAP4 that runs over SSL.
IRC	TCP/UDP	6667	This is another popular Internet chat program.
MSN Messenger	TCP	1863	Microsoft Networks' messenger service uses this protocol.
NetBIOS	TCP/UDP	137	The Network Basic Input/Output System is used for communication between computers in a LAN.
	TCP/UDP	138	
	TCP/UDP	139	
	TCP/UDP	445	
NEW-ICQ	TCP	5190	An Internet chat program.
NEWS	TCP	144	A protocol for news groups.
NFS	UDP	2049	Network File System - NFS is a client/server distributed file service that provides transparent file sharing for network environments.
NNTP	TCP	119	Network News Transport Protocol is the delivery mechanism for the USENET newsgroup service.
PING	User-Defined	1	Packet INternet Groper is a protocol that sends out ICMP echo requests to test whether or not a remote host is reachable.

Table 69 Examples of Services (continued)

NAME	PROTOCOL	PORT(S)	DESCRIPTION
POP3	TCP	110	Post Office Protocol version 3 lets a client computer get e-mail from a POP3 server through a temporary connection (TCP/IP or other).
POP3S	TCP	995	This is a more secure version of POP3 that runs over SSL.
PPTP	TCP	1723	Point-to-Point Tunneling Protocol enables secure transfer of data over public networks. This is the control channel.
PPTP_TUNNEL (GRE)	User-Defined	47	PPTP (Point-to-Point Tunneling Protocol) enables secure transfer of data over public networks. This is the data channel.
RCMD	TCP	512	Remote Command Service.
REAL_AUDIO	TCP	7070	A streaming audio service that enables real time sound over the web.
REXEC	TCP	514	Remote Execution Daemon.
RLOGIN	TCP	513	Remote Login.
ROADRUNNER	TCP/UDP	1026	This is an ISP that provides services mainly for cable modems.
RTELNET	TCP	107	Remote Telnet.
RTSP	TCP/UDP	554	The Real Time Streaming (media control) Protocol (RTSP) is a remote control for multimedia on the Internet.
SFTP	TCP	115	The Simple File Transfer Protocol is an old way of transferring files between computers.
SMTP	TCP	25	Simple Mail Transfer Protocol is the message-exchange standard for the Internet. SMTP enables you to move messages from one e-mail server to another.
SMTPS	TCP	465	This is a more secure version of SMTP that runs over SSL.
SNMP	TCP/UDP	161	Simple Network Management Program.
SNMP-TRAPS	TCP/UDP	162	Traps for use with the SNMP (RFC: 1215).
SQL-NET	TCP	1521	Structured Query Language is an interface to access data on many different types of database systems, including mainframes, midrange systems, UNIX systems and network servers.

Table 69 Examples of Services (continued)

NAME	PROTOCOL	PORT(S)	DESCRIPTION
SSDP	UDP	1900	The Simple Service Discovery Protocol supports Universal Plug-and-Play (UPnP).
SSH	TCP/UDP	22	Secure Shell Remote Login Program.
STRM WORKS	UDP	1558	Stream Works Protocol.
SYSLOG	UDP	514	Syslog allows you to send system logs to a UNIX server.
TACACS	UDP	49	Login Host Protocol used for (Terminal Access Controller Access Control System).
TELNET	TCP	23	Telnet is the login and terminal emulation protocol common on the Internet and in UNIX environments. It operates over TCP/IP networks. Its primary function is to allow users to log into remote host systems.
TFTP	UDP	69	Trivial File Transfer Protocol is an Internet file transfer protocol similar to FTP, but uses the UDP (User Datagram Protocol) rather than TCP (Transmission Control Protocol).
VDOLIVE	TCP UDP	7000 user- defined	A videoconferencing solution. The UDP port number is specified in the application.

Open Software Announcements

End-User License Agreement for "NBG416N"

WARNING: ZyXEL Communications Corp. IS WILLING TO LICENSE THE SOFTWARE TO YOU ONLY UPON THE CONDITION THAT YOU ACCEPT ALL OF THE TERMS CONTAINED IN THIS LICENSE AGREEMENT. PLEASE READ THE TERMS CAREFULLY BEFORE COMPLETING THE INSTALLATION PROCESS AS INSTALLING THE SOFTWARE WILL INDICATE YOUR ASSENT TO THEM. IF YOU DO NOT AGREE TO THESE TERMS, THEN ZYXEL IS UNWILLING TO LICENSE THE SOFTWARE TO YOU, IN WHICH EVENT YOU SHOULD RETURN THE UNINSTALLED SOFTWARE AND PACKAGING TO THE PLACE FROM WHICH IT WAS ACQUIRED OR ZYXEL, AND YOUR MONEY WILL BE REFUNDED. HOWEVER, CERTAIN ZYXEL'S PRODUCTS MAY CONTAIN-IN PART-SOME THIRD PARTY'S FREE AND OPEN SOFTWARE PROGRAMS WHICH ALLOW YOU TO FREELY COPY, RUN, DISTRIBUTE, MODIFY AND IMPROVE THE SOFTWARE UNDER THE APPLICABLE TERMS OF SUCH THRID PARTY'S LICENSES ("OPEN-SOURCED COMPONENTS"). THE OPEN-SOURCED COMPONENTS ARE LISTED IN THE NOTICE OR APPENDIX BELOW. ZYXEL MAY HAVE DISTRIBUTED TO YOU HARDWARE AND/OR SOFTWARE, OR MADE AVAILABLE FOR ELECTRONIC DOWNLOADS THESE FREE SOFTWARE PROGRAMS OF THRID PARTIES AND YOU ARE LICENSED TO FREELY COPY, MODIFY AND REDISTRIBUTE THAT SOFTWARE UNDER THE APPLICABLE LICENSE TERMS OF SUCH THIRD PARTY. NONE OF THE STATEMENTS OR DOCUMENTATION FROM ZYXEL INCLUDING ANY RESTRICTIONS OR CONDITIONS STATED IN THIS END USER LICENSE AGREEMENT SHALL RESTRICT ANY RIGHTS AND LICENSES YOU MAY HAVE WITH RESPECT TO THE OPEN-SOURCED COMPONENTS UNDER THE APPLICABLE LICENSE TERMS OF SUCH THIRD PARTY.

1. Grant of License for Personal Use

ZyXEL Communications Corp. ("ZyXEL") grants you a non-exclusive, non-sublicense, non-transferable license to use the program with which this license is distributed (the "Software"), including any documentation files accompanying the Software ("Documentation"), for internal business use only, for up to the number of users specified in sales order and invoice. You have the right to make one backup copy of the Software and Documentation solely for archival, back-up or disaster recovery purposes. You shall not exceed the scope of the license granted

hereunder. Any rights not expressly granted by ZyXEL to you are reserved by ZyXEL, and all implied licenses are disclaimed.

2. Ownership

You have no ownership rights in the Software. Rather, you have a license to use the Software as long as this License Agreement remains in full force and effect. Ownership of the Software, Documentation and all intellectual property rights therein shall remain at all times with ZyXEL. Any other use of the Software by any other entity is strictly forbidden and is a violation of this License Agreement.

3. Copyright

The Software and Documentation contain material that is protected by international copyright law, trade secret law, international treaty provisions, and the applicable national laws of each respective country. All rights not granted to you herein are expressly reserved by ZyXEL. You may not remove any proprietary notice of ZyXEL or any of its licensors from any copy of the Software or Documentation.

4. Restrictions

You may not publish, display, disclose, sell, rent, lease, modify, store, loan, distribute, or create derivative works of the Software, or any part thereof. You may not assign, sublicense, convey or otherwise transfer, pledge as security or otherwise encumber the rights and licenses granted hereunder with respect to the Software. ZyXEL is not obligated to provide any maintenance, technical or other support for the resultant modified Software. You may not copy, reverse engineer, decompile, reverse compile, translate, adapt, or disassemble the Software, or any part thereof, nor shall you attempt to create the source code from the object code for the Software. Except as and only to the extent expressly permitted in this License, you may not market, co-brand, and private label or otherwise permit third parties to link to the Software, or any part thereof. You may not use the Software, or any part thereof, in the operation of a service bureau or for the benefit of any other person or entity. You may not cause, assist or permit any third party to do any of the foregoing. Portions of the Software utilize or include third party software and other copyright material. Acknowledgements, licensing terms and disclaimers for such material are contained in the License Notice as below for the third party software, and your use of such material is exclusively governed by their respective terms. ZyXEL has provided, as part of the Software package, access to certain third party software as a convenience. To the extent that the Software contains third party software, ZyXEL has no express or implied obligation to provide any technical or other support for such software other than compliance with the applicable license terms of such third party, and makes no warranty (express, implied or statutory) whatsoever with respect thereto. Please contact the appropriate software vendor or manufacturer directly for technical support and customer service related to its software and products.

5. Confidentiality

You acknowledge that the Software contains proprietary trade secrets of ZyXEL and you hereby agree to maintain the confidentiality of the Software using at least as great a degree of care as you use to maintain the confidentiality of your own most confidential information. You agree to reasonably communicate the terms and conditions of this License Agreement to those persons employed by you who come into contact with the Software, and to use reasonable best efforts to ensure their compliance with such terms and conditions, including, without limitation, not knowingly permitting such persons to use any portion of the Software for the purpose of deriving the source code of the Software.

6. No Warranty

THE SOFTWARE IS PROVIDED "AS IS." TO THE MAXIMUM EXTENT PERMITTED BY LAW, ZyXEL DISCLAIMS ALL WARRANTIES OF ANY KIND, EITHER EXPRESSED OR IMPLIED, INCLUDING, WITHOUT LIMITATION, IMPLIED WARRANTIES OF MERCHANTABILITY AND FITNESS FOR A PARTICULAR PURPOSE, AND NON-INFRINGEMENT. ZyXEL DOES NOT WARRANT THAT THE FUNCTIONS CONTAINED IN THE SOFTWARE WILL MEET ANY REQUIREMENTS OR NEEDS YOU MAY HAVE, OR THAT THE SOFTWARE WILL OPERATE ERROR FREE, OR IN AN UNINTERRUPTED FASHION, OR THAT ANY DEFECTS OR ERRORS IN THE SOFTWARE WILL BE CORRECTED, OR THAT THE SOFTWARE IS COMPATIBLE WITH ANY PARTICULAR PLATFORM. SOME JURISDICTIONS DO NOT ALLOW THE WAIVER OR EXCLUSION OF IMPLIED WARRANTIES SO THEY MAY NOT APPLY TO YOU. IF THIS EXCLUSION IS HELD TO BE UNENFORCEABLE BY A COURT OF COMPETENT JURISDICTION, THEN ALL EXPRESS AND IMPLIED WARRANTIES SHALL BE LIMITED IN DURATION TO A PERIOD OF THIRTY (30) DAYS FROM THE DATE OF PURCHASE OF THE SOFTWARE, AND NO WARRANTIES SHALL APPLY AFTER THAT PERIOD.

7. Limitation of Liability

IN NO EVENT WILL ZyXEL BE LIABLE TO YOU OR ANY THIRD PARTY FOR ANY INCIDENTAL OR CONSEQUENTIAL DAMAGES (INCLUDING, WITHOUT LIMITATION, INDIRECT, SPECIAL, PUNITIVE, OR EXEMPLARY DAMAGES FOR LOSS OF BUSINESS, LOSS OF PROFITS, BUSINESS INTERRUPTION, OR LOSS OF BUSINESS INFORMATION) ARISING OUT OF THE USE OF OR INABILITY TO USE THE SOFTWARE OR PROGRAM, OR FOR ANY CLAIM BY ANY OTHER PARTY, EVEN IF ZyXEL HAS BEEN ADVISED OF THE POSSIBILITY OF SUCH DAMAGES. ZyXEL's TOTAL AGGREGATE LIABILITY WITH RESPECT TO ITS OBLIGATIONS UNDER THIS AGREEMENT OR OTHERWISE WITH RESPECT TO THE SOFTWARE AND DOCUMENTATION OR OTHERWISE SHALL BE EQUAL TO THE PURCHASE PRICE, BUT SHALL IN NO EVENT EXCEED THE PRODUCT'S PRICE. BECAUSE SOME STATES/COUNTRIES DO NOT ALLOW THE EXCLUSION OR LIMITATION OF LIABILITY FOR CONSEQUENTIAL OR INCIDENTAL DAMAGES, THE ABOVE LIMITATION MAY NOT APPLY TO YOU.

8.Export Restrictions

THIS LICENSE AGREEMENT IS EXPRESSLY MADE SUBJECT TO ANY APPLICABLE LAWS, REGULATIONS, ORDERS, OR OTHER RESTRICTIONS ON THE EXPORT OF THE SOFTWARE OR INFORMATION ABOUT SUCH SOFTWARE WHICH MAY BE IMPOSED FROM TIME TO TIME. YOU SHALL NOT EXPORT THE SOFTWARE, DOCUMENTATION OR INFORMATION ABOUT THE SOFTWARE AND DOCUMENTATION WITHOUT COMPLYING WITH SUCH LAWS, REGULATIONS, ORDERS, OR OTHER RESTRICTIONS. YOU AGREE TO INDEMNIFY ZyXEL AGAINST ALL CLAIMS, LOSSES, DAMAGES, LIABILITIES, COSTS AND EXPENSES, INCLUDING REASONABLE ATTORNEYS' FEES, TO THE EXTENT SUCH CLAIMS ARISE OUT OF ANY BREACH OF THIS SECTION 8.

9.Audit Rights

ZyXEL SHALL HAVE THE RIGHT, AT ITS OWN EXPENSE, UPON REASONABLE PRIOR NOTICE, TO PERIODICALLY INSPECT AND AUDIT YOUR RECORDS TO ENSURE YOUR COMPLIANCE WITH THE TERMS AND CONDITIONS OF THIS LICENSE AGREEMENT.

10.Termination

This License Agreement is effective until it is terminated. You may terminate this License Agreement at any time by destroying or returning to ZyXEL all copies of the Software and Documentation in your possession or under your control. ZyXEL may terminate this License Agreement for any reason, including, but not limited to, if ZyXEL finds that you have violated any of the terms of this License Agreement. Upon notification of termination, you agree to destroy or return to ZyXEL all copies of the Software and Documentation and to certify in writing that all known copies, including backup copies, have been destroyed. All provisions relating to confidentiality, proprietary rights, and non-disclosure shall survive the termination of this Software License Agreement.

11.General

This License Agreement shall be construed, interpreted and governed by the laws of Republic of China without regard to conflicts of laws provisions thereof. The exclusive forum for any disputes arising out of or relating to this License Agreement shall be an appropriate court or Commercial Arbitration Association sitting in ROC, Taiwan if the parties agree to a binding arbitration. This License Agreement shall constitute the entire Agreement between the parties hereto. This License Agreement, the rights granted hereunder, the Software and Documentation shall not be assigned by you without the prior written consent of ZyXEL. Any waiver or modification of this License Agreement shall only be effective if it is in writing and signed by both parties hereto. If any part of this License Agreement is found invalid or unenforceable by a court of competent

jurisdiction, the remainder of this License Agreement shall be interpreted so as to reasonably effect the intention of the parties.

NOTE: Some components of this product incorporate free software programs covered under the open source code licenses which allows you to freely copy, modify and redistribute the software. For at least three (3) years from the date of distribution of the applicable product or software, we will give to anyone who contacts us at the ZyXEL Technical Support (support@zyxel.com.tw), for a charge of no more than our cost of physically performing source code distribution, a complete machine-readable copy of the complete corresponding source code for the version of the Programs that we distributed to you if we are in possession of such.

Notice

Information herein is subject to change without notice. Companies, names, and data used in examples herein are fictitious unless otherwise noted. No part may be reproduced or transmitted in any form or by any means, electronic or mechanical, for any purpose, except the express written permission of ZyXEL Communications Corporation.

This Product includes Linux Kernel , Busybox, dnsmasq, iptables, wireless_tools, Pptp-client and igmp proxy software under GPL 2.0 license.

GNU GENERAL PUBLIC LICENSE

Version 2, June 1991

Copyright (C) 1989, 1991 Free Software Foundation, Inc.

59 Temple Place - Suite 330, Boston, MA 02111-1307, USA

Everyone is permitted to copy and distribute verbatim copies of this license document, but changing it is not allowed.

Preamble

The licenses for most software are designed to take away your freedom to share and change it. By contrast, the GNU General Public License is intended to guarantee your freedom to share and change free software--to make sure the software is free for all its users. This General Public License applies to most of the Free Software Foundation's software and to any other program whose authors commit to using it. (Some other Free Software Foundation software is covered by the GNU Library General Public License instead.) You can apply it to your programs, too.

When we speak of free software, we are referring to freedom, not price. Our General Public Licenses are designed to make sure that you have the freedom to distribute copies of free software (and charge for this service if you wish), that you receive source code or can get it if you want it, that you can change the software or use pieces of it in new free programs; and that you know you can do these things.

To protect your rights, we need to make restrictions that forbid anyone to deny you these rights or to ask you to surrender the rights. These restrictions translate to certain responsibilities for you if you distribute copies of the software, or if you modify it. For example, if you distribute copies of such a program, whether gratis or for a fee, you must give the recipients all the rights that you have. You must make sure that they, too, receive or can get the source code. And you must show them these terms so they know their rights.

We protect your rights with two steps: (1) copyright the software, and (2) offer you this license which gives you legal permission to copy, distribute and/or modify the software. Also, for each author's protection and ours, we want to make certain that everyone understands that there is no warranty for this free software. If the software is modified by someone else and passed on, we want its recipients to know that what they have is not the original, so that any problems introduced by others will not reflect on the original authors' reputations.

Finally, any free program is threatened constantly by software patents. We wish to avoid the danger that redistributors of a free program will individually obtain patent licenses, in effect making the program proprietary. To prevent this, we have made it clear that any patent must be licensed for everyone's free use or not licensed at all.

The precise terms and conditions for copying, distribution and modification follow.

TERMS AND CONDITIONS FOR COPYING, DISTRIBUTION AND MODIFICATION

0. This License applies to any program or other work which contains a notice placed by the copyright holder saying it may be distributed under the terms of this General Public License. The "Program", below, refers to any such program or work, and a "work based on the Program" means either the Program or any derivative work under copyright law: that is to say, a work containing the Program or a portion of it, either verbatim or with modifications and/or translated into another language. (Hereinafter, translation is included without limitation in the term "modification".) Each licensee is addressed as "you". Activities other than copying, distribution and modification are not covered by this License; they are outside its scope. The act of running the Program is not restricted, and the output from the Program is covered only if its contents constitute a work based on the Program (independent of having been made by running the Program). Whether that is true depends on what the Program does.

1. You may copy and distribute verbatim copies of the Program's source code as you receive it, in any medium, provided that you conspicuously and appropriately publish on each copy an appropriate copyright notice and disclaimer of warranty; keep intact all the notices that refer to this License and to the absence of any warranty; and give any other recipients of the Program a copy of this License along with the Program. You may charge a fee for the physical act of transferring a copy, and you may at your option offer warranty protection in exchange for a fee.

2. You may modify your copy or copies of the Program or any portion of it, thus forming a work based on the Program, and copy and distribute such modifications or work under the terms of Section 1 above, provided that you also meet all of these conditions:

a) You must cause the modified files to carry prominent notices stating that you changed the files and the date of any change.

b) You must cause any work that you distribute or publish, that in whole or in part contains or is derived from the Program or any part thereof, to be licensed as a whole at no charge to all third parties under the terms of this License.

c) If the modified program normally reads commands interactively when run, you must cause it, when started running for such interactive use in the most ordinary way, to print or display an announcement including an appropriate copyright notice and a notice that there is no warranty (or else, saying that you provide a warranty) and that users may redistribute the program under these conditions, and telling the user how to view a copy of this License. (Exception: if the Program itself is interactive but does not normally print such an announcement, your work based on the Program is not required to print an announcement.)

These requirements apply to the modified work as a whole. If identifiable sections of that work are not derived from the Program, and can be reasonably considered independent and separate works in themselves, then this License, and its terms, do not apply to those sections when you distribute them as separate works. But

when you distribute the same sections as part of a whole which is a work based on the Program, the distribution of the whole must be on the terms of this License, whose permissions for other licensees extend to the entire whole, and thus to each and every part regardless of who wrote it. Thus, it is not the intent of this section to claim rights or contest your rights to work written entirely by you; rather, the intent is to exercise the right to control the distribution of derivative or collective works based on the Program. In addition, mere aggregation of another work not based on the Program with the Program (or with a work based on the Program) on a volume of a storage or distribution medium does not bring the other work under the scope of this License.

3. You may copy and distribute the Program (or a work based on it, under Section 2) in object code or executable form under the terms of Sections 1 and 2 above provided that you also do one of the following:

a) Accompany it with the complete corresponding machine-readable source code, which must be distributed under the terms of Sections 1 and 2 above on a medium customarily used for software interchange; or,

b) Accompany it with a written offer, valid for at least three years, to give any third party, for a charge no more than your cost of physically performing source distribution, a complete machine-readable copy of the corresponding source code, to be distributed under the terms of Sections 1 and 2 above on a medium customarily used for software interchange; or, c) Accompany it with the information you received as to the offer to distribute corresponding source code. (This alternative is allowed only for noncommercial distribution and only if you received the program in object code or executable form with such an offer, in accord with Subsection b above.) The source code for a work means the preferred form of the work for making modifications to it. For an executable work, complete source code means all the source code for all modules it contains, plus any associated interface definition files, plus the scripts used to control compilation and installation of the executable. However, as a special exception, the source code distributed need not include anything that is normally distributed (in either source or binary form) with the major components (compiler, kernel, and so on) of the operating system on which the executable runs, unless that component itself accompanies the executable. If distribution of executable or object code is made by offering access to copy from a designated place, then offering equivalent access to copy the source code from the same place counts as distribution of the source code, even though third parties are not compelled to copy the source along with the object code.

4. You may not copy, modify, sublicense, or distribute the Program except as expressly provided under this License. Any attempt otherwise to copy, modify, sublicense or distribute the Program is void, and will automatically terminate your rights under this License. However, parties who have received copies, or rights, from you under this License will not have their licenses terminated so long as such parties remain in full compliance.

5. You are not required to accept this License, since you have not signed it. However, nothing else grants you permission to modify or distribute the Program or its derivative works. These actions are prohibited by law if you do not accept this License. Therefore, by modifying or distributing the Program (or any work based on the Program), you indicate your acceptance of this License to do so, and all its terms and conditions for copying, distributing or modifying the Program or works based on it.

6. Each time you redistribute the Program (or any work based on the Program), the recipient automatically receives a license from the original licensor to copy, distribute or modify the Program subject to these terms and conditions. You may not impose any further restrictions on the recipients' exercise of the rights granted herein. You are not responsible for enforcing compliance by third parties to this License.

7. If, as a consequence of a court judgment or allegation of patent infringement or for any other reason (not limited to patent issues), conditions are imposed on you (whether by court order, agreement or otherwise) that contradict the conditions of this License, they do not excuse you from the conditions of this License. If you cannot distribute so as to satisfy simultaneously your obligations under this License and any other pertinent obligations, then as a consequence you may not distribute the Program at all. For example, if a patent license would not permit royalty-free redistribution of the Program by all those who receive copies directly or indirectly through you, then the only way you could satisfy both it and this License would be to refrain entirely from distribution of the Program. If any portion of this section is held invalid or unenforceable under any particular circumstance, the balance of the section is intended to apply and the section as a whole is intended to apply in other circumstances. It is not the purpose of this section to induce you to infringe any patents or other property right claims or to contest validity of any such claims; this section has the sole purpose of protecting the integrity of the free software distribution system, which is implemented by public license practices. Many people have made generous contributions to the wide range of software distributed through that system in reliance on consistent application of that system; it is up to the author/donor to decide if he or she is willing to distribute software through any other system and a licensee cannot impose that choice. This section is intended to make thoroughly clear what is believed to be a consequence of the rest of this License.

8. If the distribution and/or use of the Program is restricted in certain countries either by patents or by copyrighted interfaces, the original copyright holder who places the Program under this License may add an explicit geographical distribution limitation excluding those countries, so that distribution is permitted only in or among countries not thus excluded. In such case, this License incorporates the limitation as if written in the body of this License.

9. The Free Software Foundation may publish revised and/or new versions of the General Public License from time to time. Such new versions will be similar in

spirit to the present version, but may differ in detail to address new problems or concerns. Each version is given a distinguishing version number. If the Program specifies a version number of this License which applies to it and "any later version", you have the option of following the terms and conditions either of that version or of any later version published by the Free Software Foundation. If the Program does not specify a version number of this License, you may choose any version ever published by the Free Software Foundation.

10. If you wish to incorporate parts of the Program into other free programs whose distribution conditions are different, write to the author to ask for permission. For software which is copyrighted by the Free Software Foundation, write to the Free Software Foundation; we sometimes make exceptions for this. Our decision will be guided by the two goals of preserving the free status of all derivatives of our free software and of promoting the sharing and reuse of software generally.

NO WARRANTY

11. BECAUSE THE PROGRAM IS LICENSED FREE OF CHARGE, THERE IS NO WARRANTY FOR THE PROGRAM, TO THE EXTENT PERMITTED BY APPLICABLE LAW. EXCEPT WHEN OTHERWISE STATED IN WRITING THE COPYRIGHT HOLDERS AND/OR OTHER PARTIES PROVIDE THE PROGRAM "AS IS" WITHOUT WARRANTY OF ANY KIND, EITHER EXPRESSED OR IMPLIED, INCLUDING, BUT NOT LIMITED TO, THE IMPLIED WARRANTIES OF MERCHANTABILITY AND FITNESS FOR A PARTICULAR PURPOSE. THE ENTIRE RISK AS TO THE QUALITY AND PERFORMANCE OF THE PROGRAM IS WITH YOU. SHOULD THE PROGRAM PROVE DEFECTIVE, YOU ASSUME THE COST OF ALL NECESSARY SERVICING, REPAIR OR CORRECTION.

12. IN NO EVENT UNLESS REQUIRED BY APPLICABLE LAW OR AGREED TO IN WRITING WILL ANY COPYRIGHT HOLDER, OR ANY OTHER PARTY WHO MAY MODIFY AND/OR REDISTRIBUTE THE PROGRAM AS PERMITTED ABOVE, BE LIABLE TO YOU FOR DAMAGES, INCLUDING ANY GENERAL, SPECIAL, INCIDENTAL OR CONSEQUENTIAL DAMAGES ARISING OUT OF THE USE OR INABILITY TO USE THE PROGRAM (INCLUDING BUT NOT LIMITED TO LOSS OF DATA OR DATA BEING RENDERED INACCURATE OR LOSSES SUSTAINED BY YOU OR THIRD PARTIES OR A FAILURE OF THE PROGRAM TO OPERATE WITH ANY OTHER PROGRAMS), EVEN IF SUCH HOLDER OR OTHER PARTY HAS BEEN ADVISED OF THE POSSIBILITY OF SUCH DAMAGES.

END OF TERMS AND CONDITIONS

All other trademarks or trade names mentioned herein, if any, are the property of their respective owners.

This Product includes ppp software under below license

Copyrights:

All of the code can be freely used and redistributed. The individual source files each have their own copyright and permission notice. Pppd, pppstats and pppdump are under BSD-style notices. Some of the pppd plugins are GPL'd. Chat is public domain.

This Product includes mini_upnp software under below license

Copyright (c) 2005-2008, Thomas BERNARD

All rights reserved.

Redistribution and use in source and binary forms, with or without modification, are permitted provided that the following conditions are met:

- * Redistributions of source code must retain the above copyright notice, this list of conditions and the following disclaimer.
- * Redistributions in binary form must reproduce the above copyright notice, this list of conditions and the following disclaimer in the documentation and/or other materials provided with the distribution.
- * The name of the author may not be used to endorse or promote products derived from this software without specific prior written permission.

THIS SOFTWARE IS PROVIDED BY THE COPYRIGHT HOLDERS AND CONTRIBUTORS "AS IS" AND ANY EXPRESS OR IMPLIED WARRANTIES, INCLUDING, BUT NOT LIMITED TO, THE IMPLIED WARRANTIES OF MERCHANTABILITY AND FITNESS FOR A PARTICULAR PURPOSE ARE DISCLAIMED.

IN NO EVENT SHALL THE COPYRIGHT OWNER OR CONTRIBUTORS BE LIABLE FOR ANY DIRECT, INDIRECT, INCIDENTAL, SPECIAL, EXEMPLARY, OR CONSEQUENTIAL DAMAGES (INCLUDING, BUT NOT LIMITED TO, PROCUREMENT OF SUBSTITUTE GOODS OR SERVICES; LOSS OF USE, DATA, OR PROFITS; OR BUSINESS INTERRUPTION) HOWEVER CAUSED AND ON ANY THEORY OF LIABILITY, WHETHER IN CONTRACT, STRICT LIABILITY, OR TORT (INCLUDING NEGLIGENCE OR OTHERWISE) ARISING IN ANY WAY OUT OF THE USE OF THIS SOFTWARE, EVEN IF ADVISED OF THE POSSIBILITY OF SUCH DAMAGE.

This Product includes igmpproxy software under below license

igmpproxy - IGMP proxy based multicast router

Copyright (C) 2005 Johnny Egeland <johnny@rlo.org>

This program is free software; you can redistribute it and/or modify it under the terms of the GNU General Public License as published by the Free Software Foundation; either version 2 of the License, or (at your option) any later version.

This program is distributed in the hope that it will be useful, but WITHOUT ANY WARRANTY; without even the implied warranty of MERCHANTABILITY or FITNESS FOR A PARTICULAR PURPOSE. See the GNU General Public License for more details.

You should have received a copy of the GNU General Public License along with this program; if not, write to the Free Software Foundation, Inc., 59 Temple Place, Suite 330, Boston, MA 02111-1307 USA

This software is derived work from the following software. The original source code has been modified from it's original state by the author of igmpproxy.

smcroute 0.92 - Copyright (C) 2001 Carsten Schill <carsten@cschill.de>

- Licensed under the GNU General Public License, version 2

mROUTED 3.9-beta3 - COPYRIGHT 1989 by The Board of Trustees of Leland Stanford Junior University.

- Original license can be found in the Stanford.txt file.

This Product includes uClibc software under LGPL 2.1 license

GNU LESSER GENERAL PUBLIC LICENSE

Version 2.1, February 1999

Copyright (C) 1991, 1999 Free Software Foundation, Inc.

51 Franklin Street, Fifth Floor, Boston, MA 02110-1301 USA

Everyone is permitted to copy and distribute verbatim copies of this license document, but changing it is not allowed.

[This is the first released version of the Lesser GPL. It also counts as the successor of the GNU Library Public License, version 2, hence the version number 2.1.]

Preamble

The licenses for most software are designed to take away your freedom to share and change it. By contrast, the GNU General Public Licenses are intended to

guarantee your freedom to share and change free software--to make sure the software is free for all its users.

This license, the Lesser General Public License, applies to some specially designated software packages--typically libraries--of the Free Software Foundation and other authors who decide to use it. You can use it too, but we suggest you first think carefully about whether this license or the ordinary General Public License is the better strategy to use in any particular case, based on the explanations below.

When we speak of free software, we are referring to freedom of use, not price. Our General Public Licenses are designed to make sure that you have the freedom to distribute copies of free software (and charge for this service if you wish); that you receive source code or can get it if you want it; that you can change the software and use pieces of it in new free programs; and that you are informed that you can do these things.

To protect your rights, we need to make restrictions that forbid distributors to deny you these rights or to ask you to surrender these rights. These restrictions translate to certain responsibilities for you if you distribute copies of the library or if you modify it.

For example, if you distribute copies of the library, whether gratis or for a fee, you must give the recipients all the rights that we gave you. You must make sure that they, too, receive or can get the source code. If you link other code with the library, you must provide complete object files to the recipients, so that they can relink them with the library after making changes to the library and recompiling it. And you must show them these terms so they know their rights.

We protect your rights with a two-step method: (1) we copyright the library, and (2) we offer you this license, which gives you legal permission to copy, distribute and/or modify the library.

To protect each distributor, we want to make it very clear that there is no warranty for the free library. Also, if the library is modified by someone else and passed on, the recipients should know that what they have is not the original version, so that the original author's reputation will not be affected by problems that might be introduced by others.

Finally, software patents pose a constant threat to the existence of any free program. We wish to make sure that a company cannot effectively restrict the users of a free program by obtaining a restrictive license from a patent holder. Therefore, we insist that any patent license obtained for a version of the library must be consistent with the full freedom of use specified in this license.

Most GNU software, including some libraries, is covered by the ordinary GNU General Public License. This license, the GNU Lesser General Public License,

applies to certain designated libraries, and is quite different from the ordinary General Public License. We use this license for certain libraries in order to permit linking those libraries into non-free programs.

When a program is linked with a library, whether statically or using a shared library, the combination of the two is legally speaking a combined work, a derivative of the original library. The ordinary General Public License therefore permits such linking only if the entire combination fits its criteria of freedom. The Lesser General Public License permits more lax criteria for linking other code with the library.

We call this license the "Lesser" General Public License because it does Less to protect the user's freedom than the ordinary General Public License. It also provides other free software developers Less of an advantage over competing non-free programs. These disadvantages are the reason we use the ordinary General Public License for many libraries. However, the Lesser license provides advantages in certain special circumstances.

For example, on rare occasions, there may be a special need to encourage the widest possible use of a certain library, so that it becomes a de-facto standard. To achieve this, non-free programs must be allowed to use the library. A more frequent case is that a free library does the same job as widely used non-free libraries. In this case, there is little to gain by limiting the free library to free software only, so we use the Lesser General Public License.

In other cases, permission to use a particular library in non-free programs enables a greater number of people to use a large body of free software. For example, permission to use the GNU C Library in non-free programs enables many more people to use the whole GNU operating system, as well as its variant, the GNU/Linux operating system.

Although the Lesser General Public License is Less protective of the users' freedom, it does ensure that the user of a program that is linked with the Library has the freedom and the wherewithal to run that program using a modified version of the Library.

The precise terms and conditions for copying, distribution and modification follow. Pay close attention to the difference between a "work based on the library" and a "work that uses the library". The former contains code derived from the library, whereas the latter must be combined with the library in order to run.

TERMS AND CONDITIONS FOR COPYING, DISTRIBUTION AND MODIFICATION

0. This License Agreement applies to any software library or other program which contains a notice placed by the copyright holder or other authorized party saying it may be distributed under the terms of this Lesser General Public License (also called "this License"). Each licensee is addressed as "you".

A "library" means a collection of software functions and/or data prepared so as to be conveniently linked with application programs (which use some of those functions and data) to form executables.

The "Library", below, refers to any such software library or work which has been distributed under these terms. A "work based on the Library" means either the Library or any derivative work under copyright law: that is to say, a work containing the Library or a portion of it, either verbatim or with modifications and/or translated straightforwardly into another language. (Hereinafter, translation is included without limitation in the term "modification".)

"Source code" for a work means the preferred form of the work for making modifications to it. For a library, complete source code means all the source code for all modules it contains, plus any associated interface definition files, plus the scripts used to control compilation and installation of the library.

Activities other than copying, distribution and modification are not covered by this License; they are outside its scope. The act of running a program using the Library is not restricted, and output from such a program is covered only if its contents constitute a work based on the Library (independent of the use of the Library in a tool for writing it). Whether that is true depends on what the Library does and what the program that uses the Library does.

1. You may copy and distribute verbatim copies of the Library's complete source code as you receive it, in any medium, provided that you conspicuously and appropriately publish on each copy an appropriate copyright notice and disclaimer of warranty; keep intact all the notices that refer to this License and to the absence of any warranty; and distribute a copy of this License along with the Library.

You may charge a fee for the physical act of transferring a copy, and you may at your option offer warranty protection in exchange for a fee.

2. You may modify your copy or copies of the Library or any portion of it, thus forming a work based on the Library, and copy and distribute such modifications or work under the terms of Section 1 above, provided that you also meet all of these conditions:

a) The modified work must itself be a software library.

b) You must cause the files modified to carry prominent notices stating that you changed the files and the date of any change.

c) You must cause the whole of the work to be licensed at no charge to all third parties under the terms of this License.

d) If a facility in the modified Library refers to a function or a table of data to be supplied by an application program that uses the facility, other than as an

argument passed when the facility is invoked, then you must make a good faith effort to ensure that, in the event an application does not supply such function or table, the facility still operates, and performs whatever part of its purpose remains meaningful.

(For example, a function in a library to compute square roots has a purpose that is entirely well-defined independent of the application. Therefore, Subsection 2d requires that any application-supplied function or table used by this function must be optional: if the application does not supply it, the square root function must still compute square roots.)

These requirements apply to the modified work as a whole. If identifiable sections of that work are not derived from the Library, and can be reasonably considered independent and separate works in themselves, then this License, and its terms, do not apply to those sections when you distribute them as separate works. But when you distribute the same sections as part of a whole which is a work based on the Library, the distribution of the whole must be on the terms of this License, whose permissions for other licensees extend to the entire whole, and thus to each and every part regardless of who wrote it.

Thus, it is not the intent of this section to claim rights or contest your rights to work written entirely by you; rather, the intent is to exercise the right to control the distribution of derivative or collective works based on the Library.

In addition, mere aggregation of another work not based on the Library with the Library (or with a work based on the Library) on a volume of a storage or distribution medium does not bring the other work under the scope of this License.

3. You may opt to apply the terms of the ordinary GNU General Public License instead of this License to a given copy of the Library. To do this, you must alter all the notices that refer to this License, so that they refer to the ordinary GNU General Public License, version 2, instead of to this License. (If a newer version than version 2 of the ordinary GNU General Public License has appeared, then you can specify that version instead if you wish.) Do not make any other change in these notices.

Once this change is made in a given copy, it is irreversible for that copy, so the ordinary GNU General Public License applies to all subsequent copies and derivative works made from that copy.

This option is useful when you wish to copy part of the code of the Library into a program that is not a library.

4. You may copy and distribute the Library (or a portion or derivative of it, under Section 2) in object code or executable form under the terms of Sections 1 and 2 above provided that you accompany it with the complete corresponding machine-

readable source code, which must be distributed under the terms of Sections 1 and 2 above on a medium customarily used for software interchange.

If distribution of object code is made by offering access to copy from a designated place, then offering equivalent access to copy the source code from the same place satisfies the requirement to distribute the source code, even though third parties are not compelled to copy the source along with the object code.

5. A program that contains no derivative of any portion of the Library, but is designed to work with the Library by being compiled or linked with it, is called a "work that uses the Library". Such a work, in isolation, is not a derivative work of the Library, and therefore falls outside the scope of this License.

However, linking a "work that uses the Library" with the Library creates an executable that is a derivative of the Library (because it contains portions of the Library), rather than a "work that uses the library". The executable is therefore covered by this License. Section 6 states terms for distribution of such executables.

When a "work that uses the Library" uses material from a header file that is part of the Library, the object code for the work may be a derivative work of the Library even though the source code is not. Whether this is true is especially significant if the work can be linked without the Library, or if the work is itself a library. The threshold for this to be true is not precisely defined by law.

If such an object file uses only numerical parameters, data structure layouts and accessors, and small macros and small inline functions (ten lines or less in length), then the use of the object file is unrestricted, regardless of whether it is legally a derivative work. (Executables containing this object code plus portions of the Library will still fall under Section 6.)

Otherwise, if the work is a derivative of the Library, you may distribute the object code for the work under the terms of Section 6. Any executables containing that work also fall under Section 6, whether or not they are linked directly with the Library itself.

6. As an exception to the Sections above, you may also combine or link a "work that uses the Library" with the Library to produce a work containing portions of the Library, and distribute that work under terms of your choice, provided that the terms permit modification of the work for the customer's own use and reverse engineering for debugging such modifications.

You must give prominent notice with each copy of the work that the Library is used in it and that the Library and its use are covered by this License. You must supply a copy of this License. If the work during execution displays copyright notices, you must include the copyright notice for the Library among them, as well

as a reference directing the user to the copy of this License. Also, you must do one of these things:

a) Accompany the work with the complete corresponding machine-readable source code for the Library including whatever changes were used in the work (which must be distributed under Sections 1 and 2 above); and, if the work is an executable linked with the Library, with the complete machine-readable "work that uses the Library", as object code and/or source code, so that the user can modify the Library and then relink to produce a modified executable containing the modified Library. (It is understood that the user who changes the contents of definitions files in the Library will not necessarily be able to recompile the application to use the modified definitions.)

b) Use a suitable shared library mechanism for linking with the Library. A suitable mechanism is one that (1) uses at run time a copy of the library already present on the user's computer system, rather than copying library functions into the executable, and (2) will operate properly with a modified version of the library, if the user installs one, as long as the modified version is interface-compatible with the version that the work was made with.

c) Accompany the work with a written offer, valid for at least three years, to give the same user the materials specified in Subsection 6a, above, for a charge no more than the cost of performing this distribution.

d) If distribution of the work is made by offering access to copy from a designated place, offer equivalent access to copy the above specified materials from the same place.

e) Verify that the user has already received a copy of these materials or that you have already sent this user a copy.

For an executable, the required form of the "work that uses the Library" must include any data and utility programs needed for reproducing the executable from it. However, as a special exception, the materials to be distributed need not include anything that is normally distributed (in either source or binary form) with the major components (compiler, kernel, and so on) of the operating system on which the executable runs, unless that component itself accompanies the executable.

It may happen that this requirement contradicts the license restrictions of other proprietary libraries that do not normally accompany the operating system. Such a contradiction means you cannot use both them and the Library together in an executable that you distribute.

7. You may place library facilities that are a work based on the Library side-by-side in a single library together with other library facilities not covered by this License, and distribute such a combined library, provided that the separate distribution of

the work based on the Library and of the other library facilities is otherwise permitted, and provided that you do these two things:

a) Accompany the combined library with a copy of the same work based on the Library, uncombined with any other library facilities. This must be distributed under the terms of the Sections above.

b) Give prominent notice with the combined library of the fact that part of it is a work based on the Library, and explaining where to find the accompanying uncombined form of the same work.

8. You may not copy, modify, sublicense, link with, or distribute the Library except as expressly provided under this License. Any attempt otherwise to copy, modify, sublicense, link with, or distribute the Library is void, and will automatically terminate your rights under this License. However, parties who have received copies, or rights, from you under this License will not have their licenses terminated so long as such parties remain in full compliance.

9. You are not required to accept this License, since you have not signed it. However, nothing else grants you permission to modify or distribute the Library or its derivative works. These actions are prohibited by law if you do not accept this License. Therefore, by modifying or distributing the Library (or any work based on the Library), you indicate your acceptance of this License to do so, and all its terms and conditions for copying, distributing or modifying the Library or works based on it.

10. Each time you redistribute the Library (or any work based on the Library), the recipient automatically receives a license from the original licensor to copy, distribute, link with or modify the Library subject to these terms and conditions. You may not impose any further restrictions on the recipients' exercise of the rights granted herein. You are not responsible for enforcing compliance by third parties with this License.

11. If, as a consequence of a court judgment or allegation of patent infringement or for any other reason (not limited to patent issues), conditions are imposed on you (whether by court order, agreement or otherwise) that contradict the conditions of this License, they do not excuse you from the conditions of this License. If you cannot distribute so as to satisfy simultaneously your obligations under this License and any other pertinent obligations, then as a consequence you may not distribute the Library at all. For example, if a patent license would not permit royalty-free redistribution of the Library by all those who receive copies directly or indirectly through you, then the only way you could satisfy both it and this License would be to refrain entirely from distribution of the Library.

If any portion of this section is held invalid or unenforceable under any particular circumstance, the balance of the section is intended to apply, and the section as a whole is intended to apply in other circumstances.

It is not the purpose of this section to induce you to infringe any patents or other property right claims or to contest validity of any such claims; this section has the sole purpose of protecting the integrity of the free software distribution system which is implemented by public license practices. Many people have made generous contributions to the wide range of software distributed through that system in reliance on consistent application of that system; it is up to the author/donor to decide if he or she is willing to distribute software through any other system and a licensee cannot impose that choice.

This section is intended to make thoroughly clear what is believed to be a consequence of the rest of this License.

12. If the distribution and/or use of the Library is restricted in certain countries either by patents or by copyrighted interfaces, the original copyright holder who places the Library under this License may add an explicit geographical distribution limitation excluding those countries, so that distribution is permitted only in or among countries not thus excluded. In such case, this License incorporates the limitation as if written in the body of this License.

13. The Free Software Foundation may publish revised and/or new versions of the Lesser General Public License from time to time. Such new versions will be similar in spirit to the present version, but may differ in detail to address new problems or concerns.

Each version is given a distinguishing version number. If the Library specifies a version number of this License which applies to it and "any later version", you have the option of following the terms and conditions either of that version or of any later version published by the Free Software Foundation. If the Library does not specify a license version number, you may choose any version ever published by the Free Software Foundation.

14. If you wish to incorporate parts of the Library into other free programs whose distribution conditions are incompatible with these, write to the author to ask for permission. For software which is copyrighted by the Free Software Foundation, write to the Free Software Foundation; we sometimes make exceptions for this. Our decision will be guided by the two goals of preserving the free status of all derivatives of our free software and of promoting the sharing and reuse of software generally.

NO WARRANTY

15. BECAUSE THE LIBRARY IS LICENSED FREE OF CHARGE, THERE IS NO WARRANTY FOR THE LIBRARY, TO THE EXTENT PERMITTED BY APPLICABLE LAW. EXCEPT WHEN OTHERWISE STATED IN WRITING THE COPYRIGHT HOLDERS AND/OR OTHER PARTIES PROVIDE THE LIBRARY "AS IS" WITHOUT WARRANTY OF ANY KIND, EITHER EXPRESSED OR IMPLIED, INCLUDING, BUT NOT LIMITED TO, THE IMPLIED WARRANTIES OF MERCHANTABILITY AND FITNESS FOR A PARTICULAR

PURPOSE. THE ENTIRE RISK AS TO THE QUALITY AND PERFORMANCE OF THE LIBRARY IS WITH YOU. SHOULD THE LIBRARY PROVE DEFECTIVE, YOU ASSUME THE COST OF ALL NECESSARY SERVICING, REPAIR OR CORRECTION.

16. IN NO EVENT UNLESS REQUIRED BY APPLICABLE LAW OR AGREED TO IN WRITING WILL ANY COPYRIGHT HOLDER, OR ANY OTHER PARTY WHO MAY MODIFY AND/OR REDISTRIBUTE THE LIBRARY AS PERMITTED ABOVE, BE LIABLE TO YOU FOR DAMAGES, INCLUDING ANY GENERAL, SPECIAL, INCIDENTAL OR CONSEQUENTIAL DAMAGES ARISING OUT OF THE USE OR INABILITY TO USE THE LIBRARY (INCLUDING BUT NOT LIMITED TO LOSS OF DATA OR DATA BEING RENDERED INACCURATE OR LOSSES SUSTAINED BY YOU OR THIRD PARTIES OR A FAILURE OF THE LIBRARY TO OPERATE WITH ANY OTHER SOFTWARE), EVEN IF SUCH HOLDER OR OTHER PARTY HAS BEEN ADVISED OF THE POSSIBILITY OF SUCH DAMAGES.

END OF TERMS AND CONDITIONS

Legal Information

Copyright

Copyright © 2011 by ZyXEL Communications Corporation.

The contents of this publication may not be reproduced in any part or as a whole, transcribed, stored in a retrieval system, translated into any language, or transmitted in any form or by any means, electronic, mechanical, magnetic, optical, chemical, photocopying, manual, or otherwise, without the prior written permission of ZyXEL Communications Corporation.

Published by ZyXEL Communications Corporation. All rights reserved.

Disclaimer

ZyXEL does not assume any liability arising out of the application or use of any products, or software described herein. Neither does it convey any license under its patent rights nor the patent rights of others. ZyXEL further reserves the right to make changes in any products described herein without notice. This publication is subject to change without notice.

Certifications

Notices

Changes or modifications not expressly approved by the party responsible for compliance could void the user's authority to operate the equipment.

This device has been designed for the WLAN 2.4 GHz network throughout the EC region and Switzerland, with restrictions in France.

Ce produit est conçu pour les bandes de fréquences 2,4 GHz conformément à la législation Européenne. En France métropolitaine, suivant les décisions n°03-908 et 03-909 de l'ARCEP, la puissance d'émission ne devra pas dépasser 10 mW (10 dB) dans le cadre d'une installation WiFi en extérieur pour les fréquences comprises entre 2454 MHz et 2483,5 MHz.

Viewing Certifications

- 1 Go to <http://www.zyxel.com>.
- 2 Select your product on the ZyXEL home page to go to that product's page.
- 3 Select the certification you wish to view from this page.

Federal Communications Commission (FCC) Interference Statement

The device complies with Part 15 of FCC rules. Operation is subject to the following two conditions:

- This device may not cause harmful interference.
- This device must accept any interference received, including interference that may cause undesired operations.

This device has been tested and found to comply with the limits for a Class B digital device pursuant to Part 15 of the FCC Rules. These limits are designed to provide reasonable protection against harmful interference in a residential installation. This device generates, uses, and can radiate radio frequency energy, and if not installed and used in accordance with the instructions, may cause harmful interference to radio communications. However, there is no guarantee that interference will not occur in a particular installation.

If this device does cause harmful interference to radio/television reception, which can be determined by turning the device off and on, the user is encouraged to try to correct the interference by one or more of the following measures:

- 1 Reorient or relocate the receiving antenna.
- 2 Increase the separation between the equipment and the receiver.
- 3 Connect the equipment into an outlet on a circuit different from that to which the receiver is connected.
- 4 Consult the dealer or an experienced radio/TV technician for help.



FCC Radiation Exposure Statement

- This transmitter must not be co-located or operating in conjunction with any other antenna or transmitter.
- IEEE 802.11b or 802.11g operation of this product in the U.S.A. is firmware-limited to channels 1 through 11.
- To comply with FCC RF exposure compliance requirements, a separation distance of at least 20 cm must be maintained between the antenna of this device and all persons.

注意！

依據 低功率電波輻射性電機管理辦法

第十二條 經型式認證合格之低功率射頻電機，非經許可，公司、商號或使用者均不得擅自變更頻率、加大功率或變更原設計之特性及功能。

第十四條 低功率射頻電機之使用不得影響飛航安全及干擾合法通信；經發現有干擾現象時，應立即停用，並改善至無干擾時方得繼續使用。前項合法通信，指依電信規定作業之無線電信。低功率射頻電機須忍受合法通信或工業、科學及醫療用電波輻射性電機設備之干擾。

本機限在不干擾合法電臺與不受被干擾保障條件下於室內使用。減少電磁波影響，請妥適使用。

Notices

Changes or modifications not expressly approved by the party responsible for compliance could void the user's authority to operate the equipment.

This device has been designed for the WLAN 2.4 GHz network throughout the EC region and Switzerland, with restrictions in France.

This Class B digital apparatus complies with Canadian ICES-003.

Cet appareil numérique de la classe B est conforme à la norme NMB-003 du Canada.

Viewing Certifications

- 1 Go to <http://www.zyxel.com>.
- 2 Select your product on the ZyXEL home page to go to that product's page.

- 3 Select the certification you wish to view from this page.

ZyXEL Limited Warranty

ZyXEL warrants to the original end user (purchaser) that this product is free from any defects in materials or workmanship for a period of up to two years from the date of purchase. During the warranty period, and upon proof of purchase, should the product have indications of failure due to faulty workmanship and/or materials, ZyXEL will, at its discretion, repair or replace the defective products or components without charge for either parts or labor, and to whatever extent it shall deem necessary to restore the product or components to proper operating condition. Any replacement will consist of a new or re-manufactured functionally equivalent product of equal or higher value, and will be solely at the discretion of ZyXEL. This warranty shall not apply if the product has been modified, misused, tampered with, damaged by an act of God, or subjected to abnormal working conditions.

Note

Repair or replacement, as provided under this warranty, is the exclusive remedy of the purchaser. This warranty is in lieu of all other warranties, express or implied, including any implied warranty of merchantability or fitness for a particular use or purpose. ZyXEL shall in no event be held liable for indirect or consequential damages of any kind to the purchaser.

To obtain the services of this warranty, contact your vendor. You may also refer to the warranty policy for the region in which you bought the device at http://www.zyxel.com/web/support_warranty_info.php.

Registration

Register your product online to receive e-mail notices of firmware upgrades and information at www.zyxel.com for global products, or at www.us.zyxel.com for North American products.

End-User License Agreement for "NBG-416N"

WARNING: ZyXEL Communications Corp. IS WILLING TO LICENSE THE ENCLOSED SOFTWARE TO YOU ONLY UPON THE CONDITION THAT YOU ACCEPT ALL OF THE TERMS CONTAINED IN THIS LICENSE AGREEMENT. PLEASE READ THE TERMS CAREFULLY BEFORE COMPLETING THE INSTALLATION PROCESS AS INSTALLING THE SOFTWARE WILL INDICATE YOUR ASSENT TO THEM. IF YOU DO NOT AGREE TO THESE TERMS, THEN ZyXEL, INC. IS UNWILLING TO LICENSE THE SOFTWARE TO YOU, IN WHICH EVENT YOU SHOULD RETURN THE UNINSTALLED

SOFTWARE AND PACKAGING TO THE PLACE FROM WHICH IT WAS ACQUIRED,
AND YOUR MONEY WILL BE REFUNDED.

1 Grant of License for Personal Use

ZyXEL Communications Corp. ("ZyXEL") grants you a non-exclusive, non-sublicense, non-transferable license to use the program with which this license is distributed (the "Software"), including any documentation files accompanying the Software ("Documentation"), for internal business use only, for up to the number of users specified in sales order and invoice. You have the right to make one backup copy of the Software and Documentation solely for archival, back-up or disaster recovery purposes. You shall not exceed the scope of the license granted hereunder. Any rights not expressly granted by ZyXEL to you are reserved by ZyXEL, and all implied licenses are disclaimed.

2 Ownership

You have no ownership rights in the Software. Rather, you have a license to use the Software as long as this License Agreement remains in full force and effect. Ownership of the Software, Documentation and all intellectual property rights therein shall remain at all times with ZyXEL. Any other use of the Software by any other entity is strictly forbidden and is a violation of this License Agreement.

3 Copyright

The Software and Documentation contain material that is protected by United States Copyright Law and trade secret law, and by international treaty provisions. All rights not granted to you herein are expressly reserved by ZyXEL. You may not remove any proprietary notice of ZyXEL or any of its licensors from any copy of the Software or Documentation.

4 Restrictions

You may not publish, display, disclose, sell, rent, lease, modify, store, loan, distribute, or create derivative works of the Software, or any part thereof. You may not assign, sublicense, convey or otherwise transfer, pledge as security or otherwise encumber the rights and licenses granted hereunder with respect to the Software. Certain components of the Software, and third party open source programs included with the Software, have been or may be made available by ZyXEL on its Open Source web site (<ftp://opensource.zyxel.com>) (collectively the "Open-Sourced Components") You may modify or replace only these Open-Sourced Components; provided that you comply with the terms of this License and any applicable licensing terms governing use of the Open-Sourced Components. ZyXEL is not obligated to provide any maintenance, technical or other support for the resultant modified Software. You may not copy, reverse engineer, decompile, reverse compile, translate, adapt, or disassemble the Software, or any part thereof, nor shall you attempt to create the source code from the object code for

the Software. Except as and only to the extent expressly permitted in this License, by applicable licensing terms governing use of the Open-Sourced Components, or by applicable law, you may not market, co-brand, private label or otherwise permit third parties to link to the Software, or any part thereof. You may not use the Software, or any part thereof, in the operation of a service bureau or for the benefit of any other person or entity. You may not cause, assist or permit any third party to do any of the foregoing. Portions of the Software utilize or include third party software and other copyright material. Acknowledgements, licensing terms and disclaimers for such material are contained in the online electronic documentation for the Software (<ftp://opensource.zyxel.com>), and your use of such material is governed by their respective terms. ZyXEL has provided, as part of the Software package, access to certain third party software as a convenience. To the extent that the Software contains third party software, ZyXEL has no express or implied obligation to provide any technical or other support for such software. Please contact the appropriate software vendor or manufacturer directly for technical support and customer service related to its software and products.

5 Confidentiality

You acknowledge that the Software contains proprietary trade secrets of ZyXEL and you hereby agree to maintain the confidentiality of the Software using at least as great a degree of care as you use to maintain the confidentiality of your own most confidential information. You agree to reasonably communicate the terms and conditions of this License Agreement to those persons employed by you who come into contact with the Software, and to use reasonable best efforts to ensure their compliance with such terms and conditions, including, without limitation, not knowingly permitting such persons to use any portion of the Software for the purpose of deriving the source code of the Software.

6 No Warranty

THE SOFTWARE IS PROVIDED "AS IS." TO THE MAXIMUM EXTENT PERMITTED BY LAW, ZyXEL DISCLAIMS ALL WARRANTIES OF ANY KIND, EITHER EXPRESSED OR IMPLIED, INCLUDING, WITHOUT LIMITATION, IMPLIED WARRANTIES OF MERCHANTABILITY AND FITNESS FOR A PARTICULAR PURPOSE. ZyXEL DOES NOT WARRANT THAT THE FUNCTIONS CONTAINED IN THE SOFTWARE WILL MEET ANY REQUIREMENTS OR NEEDS YOU MAY HAVE, OR THAT THE SOFTWARE WILL OPERATE ERROR FREE, OR IN AN UNINTERRUPTED FASHION, OR THAT ANY DEFECTS OR ERRORS IN THE SOFTWARE WILL BE CORRECTED, OR THAT THE SOFTWARE IS COMPATIBLE WITH ANY PARTICULAR PLATFORM. SOME JURISDICTIONS DO NOT ALLOW THE WAIVER OR EXCLUSION OF IMPLIED WARRANTIES SO THEY MAY NOT APPLY TO YOU. IF THIS EXCLUSION IS HELD TO BE UNENFORCEABLE BY A COURT OF COMPETENT JURISDICTION, THEN ALL EXPRESS AND IMPLIED WARRANTIES SHALL BE LIMITED IN DURATION TO A PERIOD OF THIRTY (30) DAYS FROM THE DATE OF PURCHASE OF THE SOFTWARE, AND NO WARRANTIES SHALL APPLY AFTER THAT PERIOD.

7 Limitation of Liability

IN NO EVENT WILL ZyXEL BE LIABLE TO YOU OR ANY THIRD PARTY FOR ANY INCIDENTAL OR CONSEQUENTIAL DAMAGES (INCLUDING, WITHOUT LIMITATION, INDIRECT, SPECIAL, PUNITIVE, OR EXEMPLARY DAMAGES FOR LOSS OF BUSINESS, LOSS OF PROFITS, BUSINESS INTERRUPTION, OR LOSS OF BUSINESS INFORMATION) ARISING OUT OF THE USE OF OR INABILITY TO USE THE PROGRAM, OR FOR ANY CLAIM BY ANY OTHER PARTY, EVEN IF ZyXEL HAS BEEN ADVISED OF THE POSSIBILITY OF SUCH DAMAGES. ZyXEL's AGGREGATE LIABILITY WITH RESPECT TO ITS OBLIGATIONS UNDER THIS AGREEMENT OR OTHERWISE WITH RESPECT TO THE SOFTWARE AND DOCUMENTATION OR OTHERWISE SHALL BE EQUAL TO THE PURCHASE PRICE, BUT SHALL IN NO EVENT EXCEED THE PRODUCT'S PRICE. BECAUSE SOME STATES/COUNTRIES DO NOT ALLOW THE EXCLUSION OR LIMITATION OF LIABILITY FOR CONSEQUENTIAL OR INCIDENTAL DAMAGES, THE ABOVE LIMITATION MAY NOT APPLY TO YOU.

8 Export Restrictions

THIS LICENSE AGREEMENT IS EXPRESSLY MADE SUBJECT TO ANY APPLICABLE LAWS, REGULATIONS, ORDERS, OR OTHER RESTRICTIONS ON THE EXPORT OF THE SOFTWARE OR INFORMATION ABOUT SUCH SOFTWARE WHICH MAY BE IMPOSED FROM TIME TO TIME. YOU SHALL NOT EXPORT THE SOFTWARE, DOCUMENTATION OR INFORMATION ABOUT THE SOFTWARE AND DOCUMENTATION WITHOUT COMPLYING WITH SUCH LAWS, REGULATIONS, ORDERS, OR OTHER RESTRICTIONS. YOU AGREE TO INDEMNIFY ZyXEL AGAINST ALL CLAIMS, LOSSES, DAMAGES, LIABILITIES, COSTS AND EXPENSES, INCLUDING REASONABLE ATTORNEYS' FEES, TO THE EXTENT SUCH CLAIMS ARISE OUT OF ANY BREACH OF THIS SECTION 8.

9 Audit Rights

ZyXEL SHALL HAVE THE RIGHT, AT ITS OWN EXPENSE, UPON REASONABLE PRIOR NOTICE, TO PERIODICALLY INSPECT AND AUDIT YOUR RECORDS TO ENSURE YOUR COMPLIANCE WITH THE TERMS AND CONDITIONS OF THIS LICENSE AGREEMENT.

10 Termination

This License Agreement is effective until it is terminated. You may terminate this License Agreement at any time by destroying or returning to ZyXEL all copies of the Software and Documentation in your possession or under your control. ZyXEL may terminate this License Agreement for any reason, including, but not limited to, if ZyXEL finds that you have violated any of the terms of this License Agreement. Upon notification of termination, you agree to destroy or return to ZyXEL all copies of the Software and Documentation and to certify in writing that all known copies, including backup copies, have been destroyed. All provisions

relating to confidentiality, proprietary rights, and non-disclosure shall survive the termination of this Software License Agreement.

11 General

This License Agreement shall be construed, interpreted and governed by the laws of Republic of China without regard to conflicts of laws provisions thereof. The exclusive forum for any disputes arising out of or relating to this License Agreement shall be an appropriate court or Commercial Arbitration Association sitting in ROC, Taiwan. This License Agreement shall constitute the entire Agreement between the parties hereto. This License Agreement, the rights granted hereunder, the Software and Documentation shall not be assigned by you without the prior written consent of ZyXEL. Any waiver or modification of this License Agreement shall only be effective if it is in writing and signed by both parties hereto. If any part of this License Agreement is found invalid or unenforceable by a court of competent jurisdiction, the remainder of this License Agreement shall be interpreted so as to reasonably effect the intention of the parties.

Note: NOTE: Some components of the Vantage CNM 2.3 incorporate source code covered under the Apache License, GPL License, LGPL License, Sun License, and Castor License. To obtain the source code covered under those Licenses, please check <ftp://opensource.zyxel.com> to get it.

Index

A

Address Assignment [84](#)
Alert [131](#)
alternative subnet mask notation [160](#)
AP [19](#)
AP (Access Point) [195](#)
AP Mode
 menu [52](#)
 overview [49](#)
 status screen [50](#)
AP+Bridge [19](#)

B

Backup configuration [136](#)
Bridge/Repeater [19](#)
BSS [193](#)

C

CA [200](#)
Certificate Authority [200](#)
certifications
 notices [231](#), [233](#)
 viewing [232](#), [233](#)
Channel [29](#), [51](#), [195](#)
 Interference [195](#)
channel [68](#)
Configuration
 backup [136](#)
 reset the factory defaults [138](#)
 restore [137](#)
copyright [231](#)
CPU usage [29](#), [51](#)
CTS (Clear to Send) [196](#)

D

Daylight saving [128](#)
DHCP [32](#), [95](#)
 DHCP server
 see also Dynamic Host Configuration Protocol
DHCP client information [98](#)
DHCP client list [98](#)
DHCP server [92](#), [95](#)
DHCP table [32](#), [98](#)
 DHCP client information
 DHCP status
Dimensions [153](#)
disclaimer [231](#)
DNS [45](#), [97](#)
 DNS server
 see also Domain name system
DNS Server [84](#)
DNS server [97](#)
Domain name [37](#)
 vs host name. see also system name
Domain Name System [97](#)
Domain Name System. See DNS.
duplex setting [30](#), [52](#)
Dynamic Host Configuration Protocol [95](#)
Dynamic WEP Key Exchange [200](#)

E

EAP Authentication [199](#)
Encryption [201](#)
encryption [70](#)
 and local (user) database [70](#)
 key [70](#)
 WPA compatible [70](#)
ESS [194](#)
ESSID [150](#)
Extended Service Set [194](#)
Extended wireless security [39](#)

F

- Factory LAN defaults [92, 95](#)
- FCC interference statement [232](#)
- Firewall
 - ICMP packets [111](#)
 - ZyXEL device firewall [110](#)
- firewall
 - stateful inspection [109](#)
- Firmware upload [133](#)
 - file extension
 - using HTTP
- firmware version [29, 51](#)
- Fragmentation Threshold [197](#)

G

- General wireless LAN screen [71](#)

H

- Hidden Node [195](#)

I

- IANA [166](#)
- IBSS [193](#)
- IEEE 802.11g [197](#)
- Independent Basic Service Set [193](#)
- Internet Assigned Numbers Authority
 - See IANA
- Internet connection
 - Ethernet
 - PPPoE. see also PPP over Ethernet
 - PPTP
 - WAN connection
- Internet connection wizard [39](#)
- IP Address [93, 105](#)
- IP address [44](#)
 - dynamic
- IP Pool [96](#)

L

- LAN [91](#)
 - IP pool setup [92](#)
- LAN overview [91](#)
- LAN setup [91](#)
- LAN TCP/IP [92](#)
- Language [143](#)
- Link type [30, 51](#)
- local (user) database [69](#)
 - and encryption [70](#)
- Local Area Network [91](#)
- Log [131](#)

M

- MAC [76](#)
- MAC address [69, 84](#)
 - cloning [47, 85](#)
- MAC address filter [69](#)
- MAC address filtering [76](#)
- MAC filter [76](#)
- managing the device
 - good habits [20](#)
 - using the Web Configurator. See Web Configurator.
 - using the WPS. See WPS.
- MBSSID [19](#)
- Media access control [76](#)
- Memory usage [29, 51](#)
- mode [19](#)

N

- NAT [101, 104, 165](#)
 - global [102](#)
 - how it works [101, 103](#)
 - inside [102](#)
 - local [102](#)
 - outside [102](#)
 - overview [101](#)
 - port forwarding [107](#)
 - see also Network Address Translation

- server [103](#)
- server sets [107](#)
- NAT traversal [117](#)
- Navigation Panel [30, 52](#)
- navigation panel [30, 52](#)
- Network Address Translation [101, 104](#)

O

- operating mode [19](#)

P

- Point-to-Point Protocol over Ethernet [40, 87](#)
- Point-to-Point Tunneling Protocol [42, 88](#)
- Pool Size [96](#)
- Port forwarding [105, 107](#)
 - default server [105, 107](#)
 - example [108](#)
 - local server [105](#)
 - port numbers
 - services
- port speed [30, 52](#)
- Power Specification [153](#)
- PPPoE [40, 87](#)
 - benefits [41](#)
 - dial-up connection
 - see also Point-to-Point Protocol over Ethernet [40](#)
- PPTP [42, 88](#)
 - see also Point-to-Point Tunneling Protocol [42](#)
- Preamble Mode [197](#)
- product registration [234](#)

Q

- Quality of Service (QoS) [79](#)

R

- RADIUS [198](#)
 - Shared Secret Key [199](#)
- RADIUS Message Types [199](#)
- RADIUS Messages [199](#)
- RADIUS server [69](#)
- registration
 - product [234](#)
- related documentation [3](#)
- Remote management [113](#)
 - and NAT [114](#)
 - and the firewall [113](#)
 - limitations [114](#)
 - system timeout [114](#)
- Reset button [27, 138](#)
- Reset the device [27](#)
- Restore configuration [137](#)
- RF (Radio Frequency) [154](#)
- Roaming [77](#)
- RTS (Request To Send) [196](#)
- RTS Threshold [195, 196](#)
- RTS/CTS Threshold [68, 77](#)

S

- safety warnings [8](#)
- Scheduling [81](#)
- Security Parameters [204](#)
- Service Set [72](#)
- Service Set IDentification [72](#)
- Service Set IDentity. See SSID.
- services
 - and port numbers [205](#)
 - and protocols [205](#)
- SSID [29, 51, 68, 72](#)
- stateful inspection firewall [109](#)
- Static DHCP [96](#)
- Status [28](#)
- subnet [157](#)
- Subnet Mask [93](#)
- subnet mask [45, 158](#)
- subnetting [161](#)

- Summary
 - DHCP table [32](#)
 - Packet statistics [33](#)
 - Wireless station status [34](#)
- syntax conventions [6](#)
- Sys Op Mode [139](#)
- System General Setup [125](#)
- System Name [126](#)
- System name [36](#)
 - vs computer name
- System restart [138](#)

T

- TCP/IP configuration [95](#)
- Temperature [153](#)
- Time setting [127](#)

U

- Universal Plug and Play [117](#)
 - application [117](#)
- UPnP [117](#)
 - security issues [118](#)
- Use Authentication [202](#)
- user authentication [69](#)
 - local (user) database [69](#)
 - RADIUS server [69](#)

V

- VPN [88](#)

W

- WAN
 - IP address assignment [44](#)
- WAN (Wide Area Network) [83](#)
- WAN IP address [44](#)
- WAN IP address assignment [46](#)

- WAN MAC address [84](#)
- warranty [234](#)
 - note [234](#)
- Web Configurator [20](#)
 - how to access [25](#)
 - Overview [25](#)
- Web configurator
 - navigating [27](#)
- WEP Encryption [74](#)
- WEP encryption [73](#)
- WEP key [73](#)
- Wireless association list [34](#)
- wireless channel [150](#)
- wireless LAN [150](#)
- wireless LAN scheduling [81](#)
- Wireless LAN wizard [38](#)
- Wireless network
 - basic guidelines [68](#)
 - channel [68](#)
 - encryption [70](#)
 - example [67](#)
 - MAC address filter [69](#)
 - overview [67](#)
 - security [68](#)
 - SSID [68](#)
- Wireless security [68](#)
 - overview [68](#)
 - type [68](#)
- wireless security [150](#)
- Wireless tutorial [49, 57](#)
 - WPS [57](#)
- Wizard setup [35](#)
 - complete [48](#)
 - Internet connection [39](#)
 - system information [36](#)
 - wireless LAN [38](#)
- WLAN
 - Interference [195](#)
 - Security Parameters [204](#)
- WPA compatible [70](#)
- WPA, WPA2 [201](#)
- WPS [20](#)

