

WF-2404
User Manual

netis 300Mbps Wireless-N
Broadband Router

V1.3
2011-05-18

Certification

FCC CE

FCC Statement

This equipment has been tested and found to comply with the limits for a Class B digital device, pursuant to part 15 of the FCC rules. These limits are designed to provide reasonable protection against harmful interference in a residential installation. This equipment generates, uses and can radiate radio frequency energy and, if not installed and used in accordance with the instructions, may cause harmful interference to radio communications. However, there is no guarantee that interference will not occur in a particular installation. If this equipment does cause harmful interference to radio or television reception, which can be determined by turning the equipment off and on, the user is encouraged to try to correct the interference by one or more of the following measures:

- Reorient or relocate the receiving antenna.
- Increase the separation between the equipment and receiver.
- Connect the equipment into an outlet on a circuit different from that to which the receiver is connected.
- Consult the dealer or an experienced radio/TV technician for help.

To assure continued compliance, any changes or modifications not expressly approved by the party responsible for compliance could void the user's authority to operate this equipment. (Example- use only shielded interface cables when connecting to computer or peripheral devices)

FCC Radiation Exposure Statement

This equipment complies with FCC RF radiation exposure limits set forth for an uncontrolled environment. This transmitter must not be co-located or operating in conjunction with any other antenna or transmitter.

This equipment complies with Part 15 of the FCC Rules. Operation is subject to the following two conditions:

- (1) This device may not cause harmful interference, and
- (2) This device must accept any interference received, including interference that may cause undesired operation.

Caution!

The manufacturer is not responsible for any radio or TV interference caused by unauthorized modifications to this equipment. Such modifications could void the user authority to operate the equipment

Package Contents

The following items should be found in your package:

- 300Mbps Wireless-N Broadband Router
- Power adapter
- Quick Installation Guide
- CD-Rom
- Ethernet cable

Make sure that the package contains above items. If any of the above items is missing or damaged, please contact the store you bought this product from.

Brand and Copyright Announcement

Copyright © 2010 Netis Corporation.

All rights reserved



is a registered trademark of Netis Corporation. Other trademarks and trade names may be used in this document to refer to either the entities claiming the marks and names or their products.

Reproduction in any manner without the permission of Netis Corporation is strictly forbidden

All the information in this document is subject to change without notice.

USA/Canada Technical Support

Phone: 1-866-71-network or 1-866-716-3896 (free in USA & Canada)

E-mail: usa_support@netis-systems.com

Contents

CONTENTS	3
1. INTRODUCTION	6
1.1. PRODUCT OVERVIEW.....	6
1.2. MAIN FEATURES	6
1.3. SUPPORTING STANDARD AND PROTOCOL.....	7
1.4. WORKING ENVIRONMENT.....	7
2. HARDWARE INSTALLATION	8
2.1. SYSTEM REQUIREMENT	8
2.2. PANEL.....	8
2.3. RESTORE TO FACTORY CONFIGURATION	9
2.4. HARDWARE INSTALLATION PROCEDURES	9
3. LOGIN	11
3.1. CONFIGURE COMPUTER.....	11
3.1.1. Windows 98/Me	11
3.1.2. Windows 2000	11
3.1.3. Windows XP	14
3.1.4. Windows Vista	17
3.1.5. Windows 7.....	21
3.1.6. MAC OS	23
3.2. CHECKING CONNECTION WITH THE ROUTER	25
3.3. LOGIN.....	26
4. ROUTER SETUP	28
4.1. STATUS.....	28
4.1.1. Version.....	28
4.1.2. WAN.....	28
4.1.3. LAN	29
4.1.4. Wireless	29
4.1.5. Router Status	30
4.1.6. Traffic Statistics.....	30
4.2. QUICK SETUP.....	30
4.2.1. DHCP (dynamic).....	30
4.2.2. PPPoE.....	31
4.2.3. Static.....	31
4.2.4. Wireless Configuration.....	32
4.2.5. MAC Clone.....	32
4.3. WPS SETTINGS	33
4.3.1. WPS Settings	33
4.3.2. Add a New Device	33
4.3.3. WPS Configuration	34

4.4.	NETWORK.....	35
4.4.1.	WAN.....	35
4.4.1.1.	Wired Access.....	35
4.4.1.2.	Wireless Access.....	36
4.4.2.	LAN.....	37
4.4.3.	MAC Clone.....	37
4.4.4.	Port Settings.....	37
4.4.5.	IGMP Proxy.....	38
4.5.	WIRELESS.....	38
4.5.1.	Wireless Settings.....	38
4.5.2.	Wireless Security.....	39
4.5.2.1.	None.....	40
4.5.2.2.	WEP.....	40
4.5.2.3.	WPA-PSK.....	41
4.5.2.4.	WPA2-PSK.....	41
4.5.2.5.	WPA/WPA2-PSK.....	41
4.5.3.	Wireless MAC Filtering.....	42
4.5.4.	WDS Settings.....	43
4.5.5.	Repeater Settings.....	44
4.5.6.	Wireless Advanced.....	46
4.5.7.	Wireless Statistics.....	48
4.5.8.	Multiple AP Settings.....	48
4.6.	DHCP.....	49
4.6.1.	DHCP Settings.....	49
4.6.2.	DHCP Clients List.....	49
4.6.3.	Address Reservation.....	50
4.7.	FORWARDING.....	50
4.7.1.	Virtual Servers.....	50
4.7.2.	Port Triggering.....	51
4.7.3.	DMZ.....	51
4.7.4.	UPnP.....	52
4.7.5.	FTP Private Port.....	52
4.8.	SECURITY.....	52
4.8.1.	Security Settings.....	52
4.8.2.	IP Address Filtering.....	53
4.8.3.	MAC Filtering.....	54
4.8.4.	Domain Filtering.....	55
4.9.	STATIC ROUTING.....	56
4.10.	QOS SETTINGS.....	57
4.11.	DYNAMIC DNS.....	57
4.12.	SYSTEM TOOLS.....	58
4.12.1.	Firmware.....	58
4.12.2.	Time Settings.....	58
4.12.3.	Password.....	59

4.12.4.	WOL.....	59
4.12.5.	System Logs.....	59
4.12.6.	Remote Management.....	60
4.12.7.	Factory Defaults.....	60
4.12.8.	Reboot.....	60
4.13.	ABOUT.....	61
5.	TROUBLESHOOTING	61

1. Introduction

1.1. Product Overview

The 300Mbps Wireless-N Broadband Router is dedicated to Small Office/Home Office (SOHO) Wireless network solution. It is 4 in 1 network device, which combines wireless access point, firewall, 4-port Switch and the NAT-Router. It provides up to 300Mbps data transmission rate in 2.4GHz frequency, complies with IEEE 802.11n, IEEE 802.11g and IEEE802.11b and backwards compatible with all IEEE 802.11n/g/b devices. And the router also supports wireless LAN up to 128-bit WEP, WPA/WPA2 encryption security. The 300Mbps Wireless-N Broadband Router also provides WEB and Remote Management and system log so that network administrators can manage and monitor the network in real time.

The 300Mbps Wireless-N Broadband Router also provides a hardware WPS (Wi-Fi protected setup) button, which helps you setup a secure wireless network in a snap. The button lets you activate the wireless protection easily

1.2. Main Features

- Comply with IEEE802.11n/g/b, IEEE802.3 10Base-T, IEEE802.3u 100Base-TX standards
- Support MIMO technology with 2 transmit and 2 receive, up to 300Mbps wireless LAN data transfer rates
- Support DHCP Client, PPPoE Client, Static IP, L2TP, PPTP
- Support multi-wireless mode: AP, WDS, AP+WDS, repeater, client, etc.
- Support static ARP, MAC filtering, IP access control, DNS filter
- Support FTP, PPTP and L2TP pass through
- Support UPNP (universal plug and play)
- Upgradeable firmware for future functions
- WPS button can easily setup a secure network
- Support WMM
- Support data encryption mode: WEP, WPA, WPA2
- Support DMZ

1.3. Supporting Standard and Protocol

- IEEE 802.11b/g/n
- IEEE 802.11e
- IEEE 802.11h
- IEEE 802.11k
- IEEE 802.11i
- IEEE 802.3 10Base-T
- IEEE 802.3u 100Base-TX

1.4. Working Environment

Temperature

- 0 °to 40 °C (operating)
- -40 °to 70 °C (storage)

Humidity

- 10% to 90 % non-condensing (operating)
- 5% to 90% non-condensing (storage)

Power

- DC 9V

2. Hardware Installation

2.1. System Requirement

Minimum Requirements:

- Broadband (DSL/Cable) modem and service with Ethernet port
- 802.11n b/g/n wireless adapter or Ethernet adapter and cable for each computer
- Internet Explorer® 5.0, Firefox® 2.0 or Safari® 1.4 or higher

2.2. Panel

Front panel

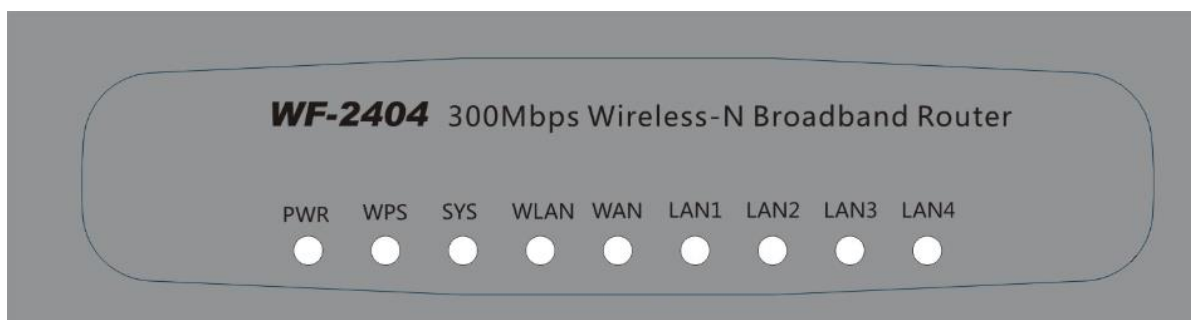

Figure 2-1

LED	Function	
PWR	ON	Power on
	Off	Power off
WPS	Flashing slowly	WPS is running
	OFF	WPS is not running
SYS	ON and Off	Abnormal
	Flashing	Normal
WLAN	Flashing	Wireless data transmitting
	Off	Wireless off
WAN	On	WAN Connection normal
	Flashing	Data transmitting
	Off	WAN Connection abnormal
LAN	On	LAN Connection normal
	Flashing	Data transmitting

	Off	LAN Connection abnormal
--	-----	-------------------------

Rear panel

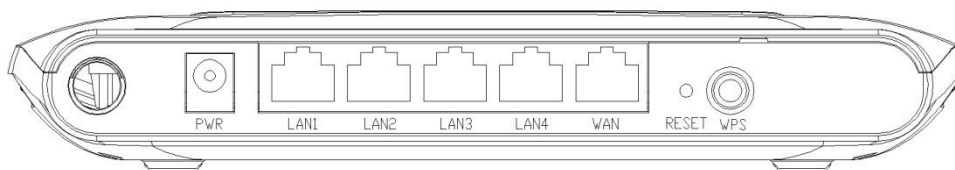

Figure 2-2

Description	Function
PWR	Connect to Power adapter, please don't use the unknown power adapter, otherwise your device may be damaged.
LAN	Connect with computer NIC or Ethernet device
WAN	Internet access
Reset	Restore settings

2.3. Restore to factory configuration

If the router ever freezes in a setting change process or if you can't access it because you can't remember the IP you have given it or other problem, you may have to utilize the reset button on the back of the router to put it back to factory settings. You have to press and hold this button for a few seconds (2-6s) with a pencil when it is working, then release and it will restore settings to the factory configuration.

The other way to restore factory settings is through the same user interface used in setup. Click on 'System management'- 'Restore', and click on the 'Restore' button.

2.4. Hardware Installation Procedures

The procedures to install the 300Mbps Wireless-N Broadband Router please refers to the following picture

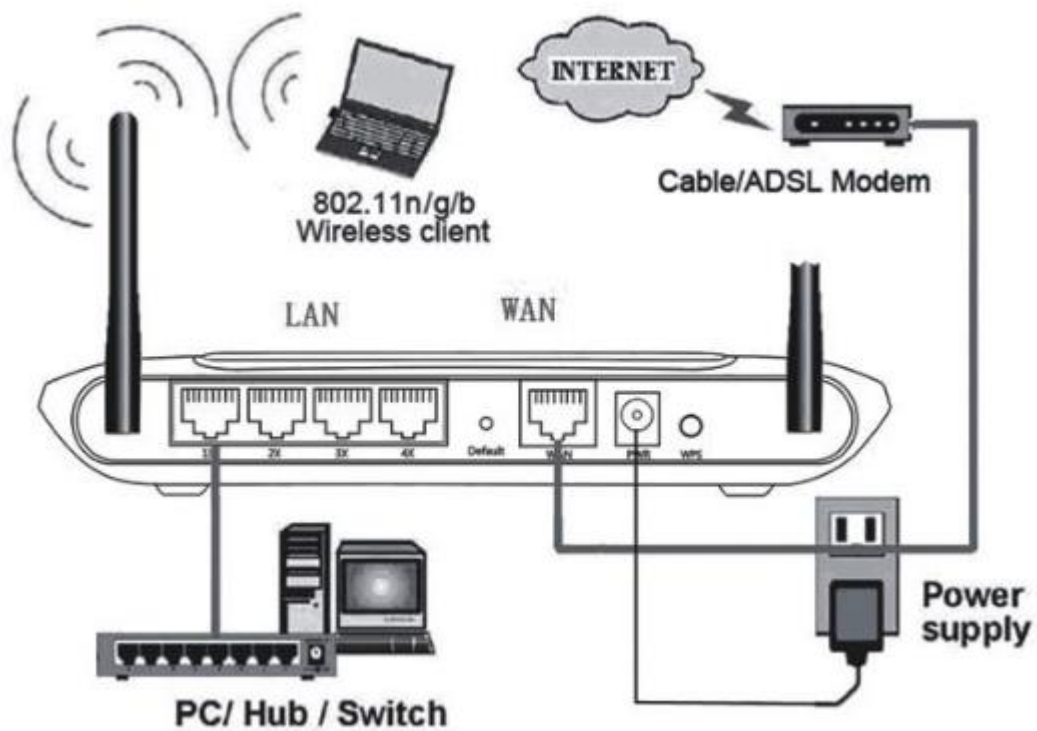

Figure 2-3

- Attach one end of an Ethernet cable to your computer's Ethernet port, and the other end to one of the LAN ports of your router.
- Connect another Ethernet cable from your Cable/DSL modem to the WAN port of your router.
- Connect the single DC output connector of the power adapter to the power jack on the back of the router and plug the Power Adapter into an AC outlet.

3. Login

You can manage the 300Mbps Wireless-N Broadband Router through the Web browser-based configuration utility. To configure the device via Web browser, at least one properly configured computer must be connected to the device via Ethernet or wireless network. The 300Mbps Wireless-N Broadband Router is configured with the **default IP address of 192.168.1.1** and **subnet mask of 255.255.255.0** and its **DHCP server is enabled by default**. Before setting up the Router, make sure your PCs are configured to obtain an IP address automatically from the Router by the steps below.

3.1. Configure computer

3.1.1. Windows 98/Me

1. Go to Start → Settings → Control Panel.
2. Find and double-click the Network icon. The Network dialog box appears.
3. Click the Configuration label and ensure that you have network card.
4. Select TCP/IP. If TCP/IP appears more than once, please select the item that has an arrow “→” pointing to the network card installed on your computer. DO NOT choose the instance of TCP/IP with the words “Dial Up Adapter” beside it.
5. Click Properties. The TCP/IP Properties dialog box appears.
6. Ensure the Obtain IP Address Automatically is checked.
7. From the WINS Configuration dialog box, Ensure that Disable WINS Resolution is checked.
8. From the Gateway dialog box, remove all entries from the Installed gateways by selecting them and clicking Remove.
9. From the DNS Configuration dialog box, remove all entries from the DNS Server Search Order box by selecting them and clicking Remove. Remove all entries from the Domain Suffix Search Order box by selecting them and clicking Remove. Click Disable DNS.
10. Click OK, back to Network Configuration dialog box
11. Click OK, if prompted to restart, click YES.

3.1.2. Windows 2000

Please follow the steps below to setup your computer:

1. Go to Start → Settings → Control Panel



Figure 3-1

2. Double click the icon Network and Dial-up Connections
3. Highlight the icon Local Area Connection, right click your mouse, and click Properties

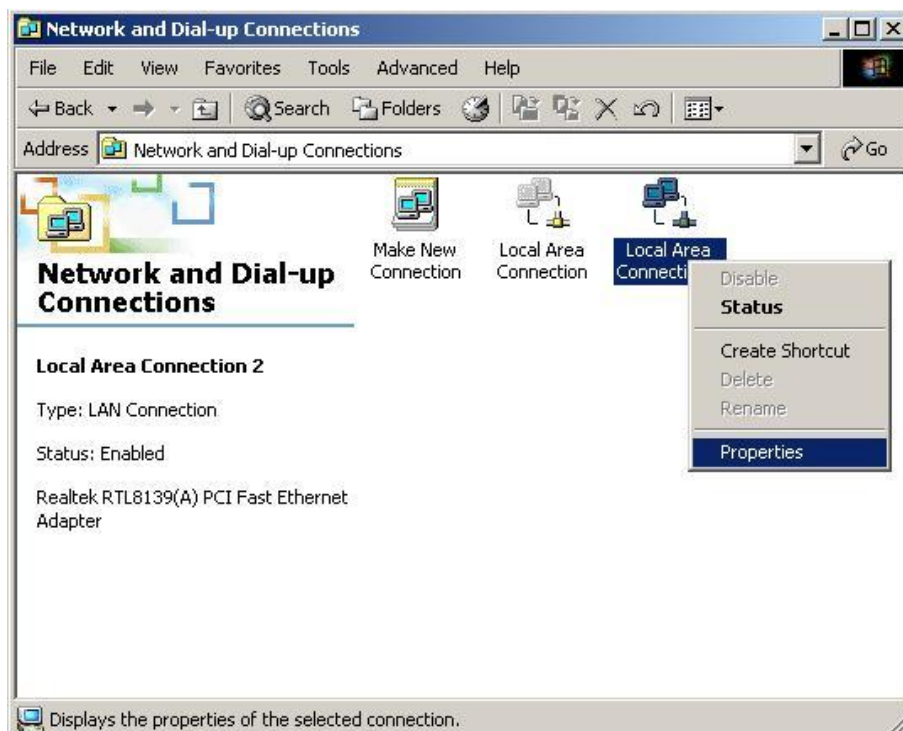

Figure 3-2

4. Highlight Internet Protocol (TCP/IP), and then press Properties button



Figure 3-3

5. Choose Obtain an IP address automatically and Obtain DNS server address automatically, and then press OK to close the Internet Protocol (TCP/IP) Properties window

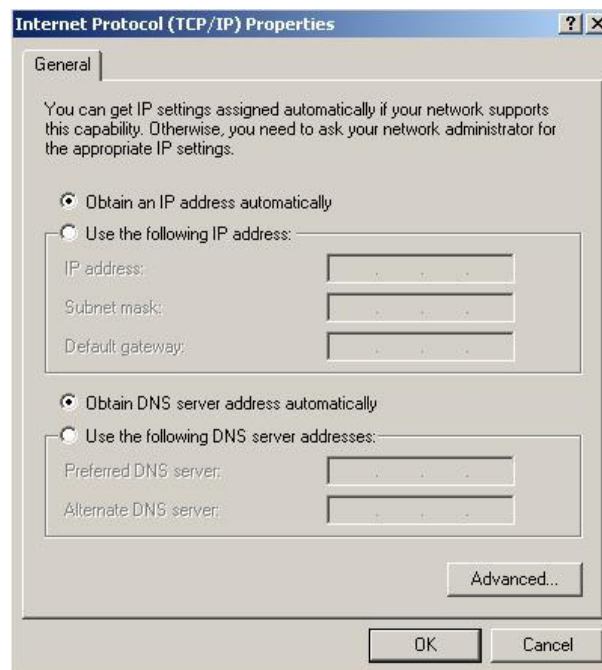

Figure 3-4

6. Press OK to close the Local Area Connection Properties window

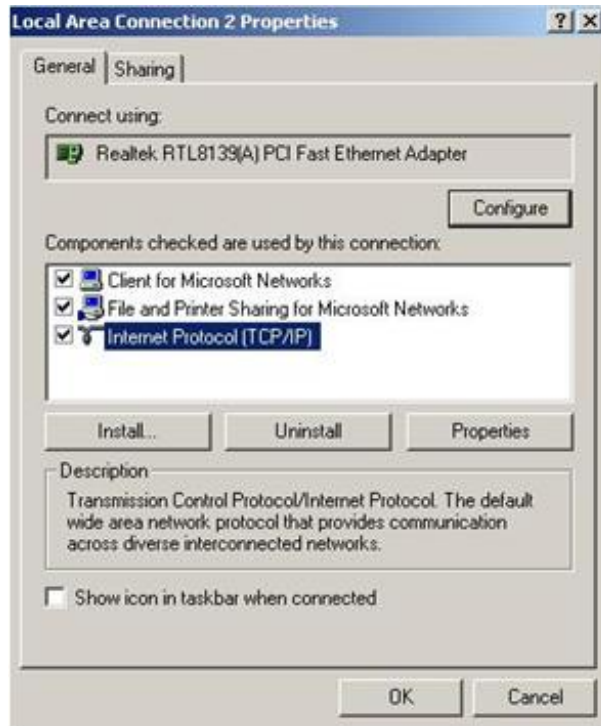

Figure 3-5

3.1.3. Windows XP

Please follow the steps below to setup your computer:

1. Go to Start → Settings → Control Panel
2. Click Network and Internet Connections

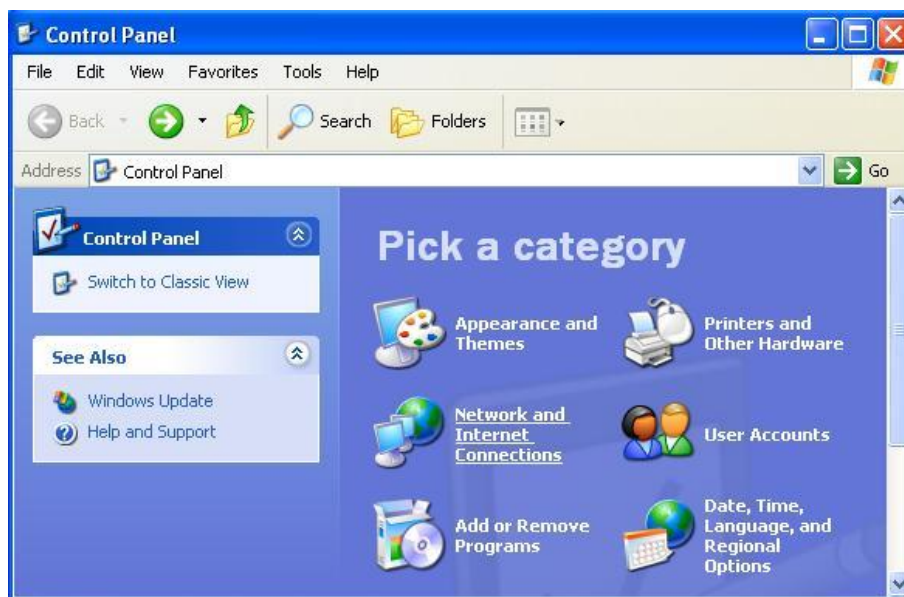

Figure 3-6

3. Click Network Connections



Figure 3-7

4. Highlight the icon Local Area Connection, right click your mouse, and click Properties

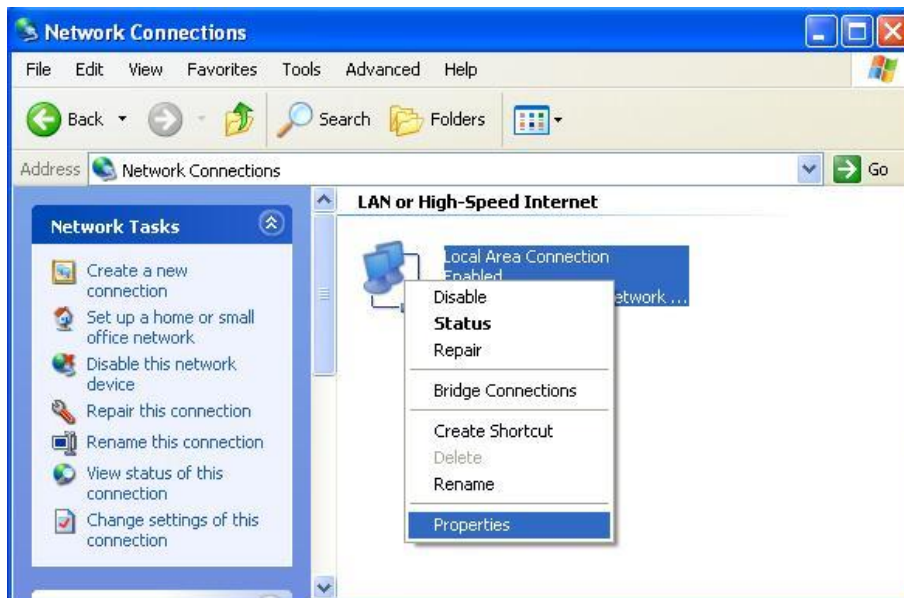

Figure 3-8

5. Highlight Internet Protocol (TCP/IP), and then press Properties button

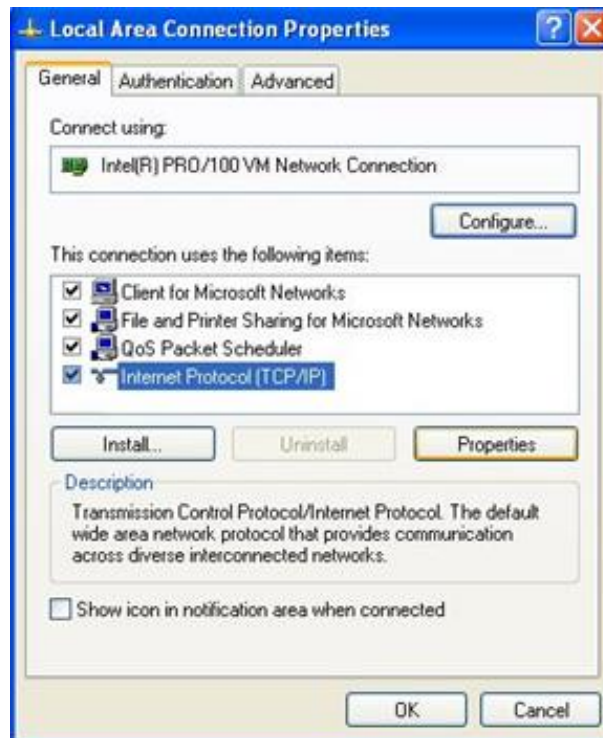

Figure 3-9

6. Choose Obtain an IP address automatically and Obtain DNS server address automatically, and then press OK to close the Internet Protocol (TCP/IP) Properties window

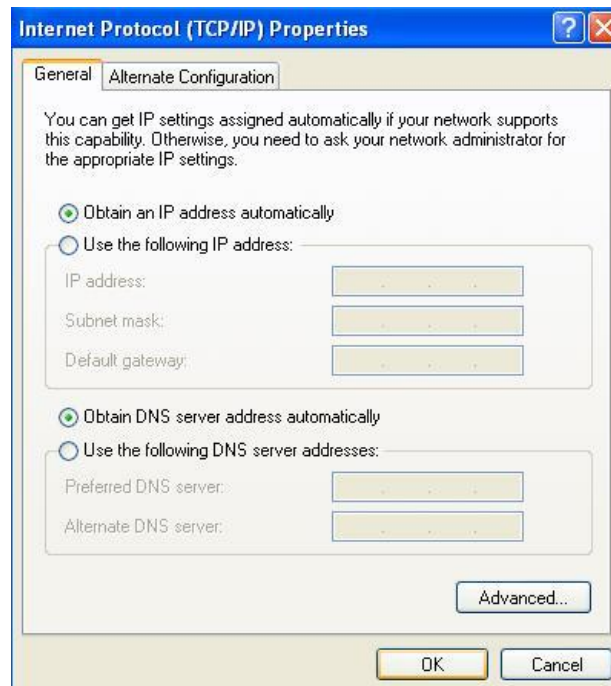

Figure 3-10

7. Press OK to close the Local Area Connection Properties window



Figure 3-11

3.1.4. Windows Vista

Please follow the steps below to setup your computer:

1. Go to Start → Settings → Control Panel
2. Click Network and Sharing Center

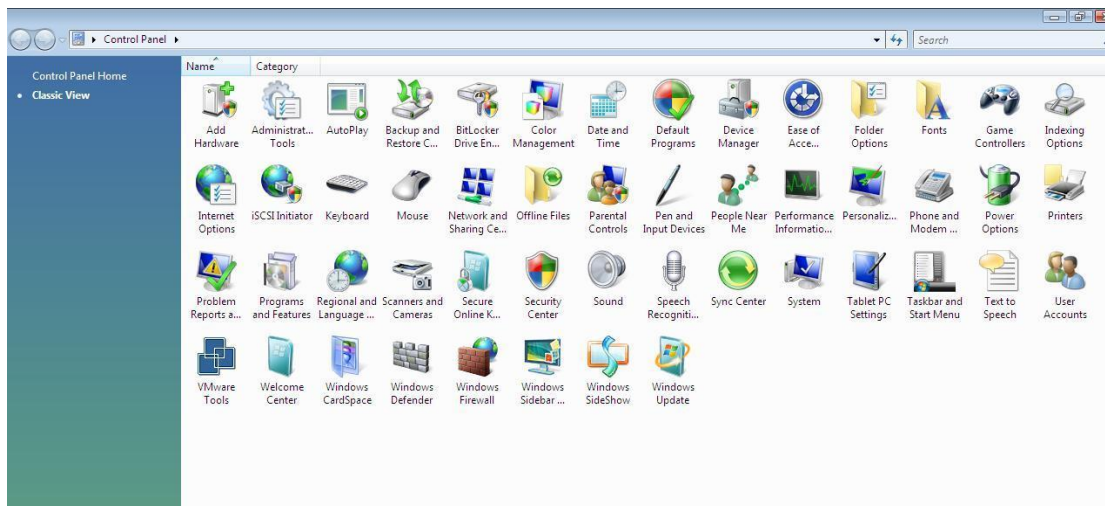

Figure 3-12

3. Click Manage Network Connections

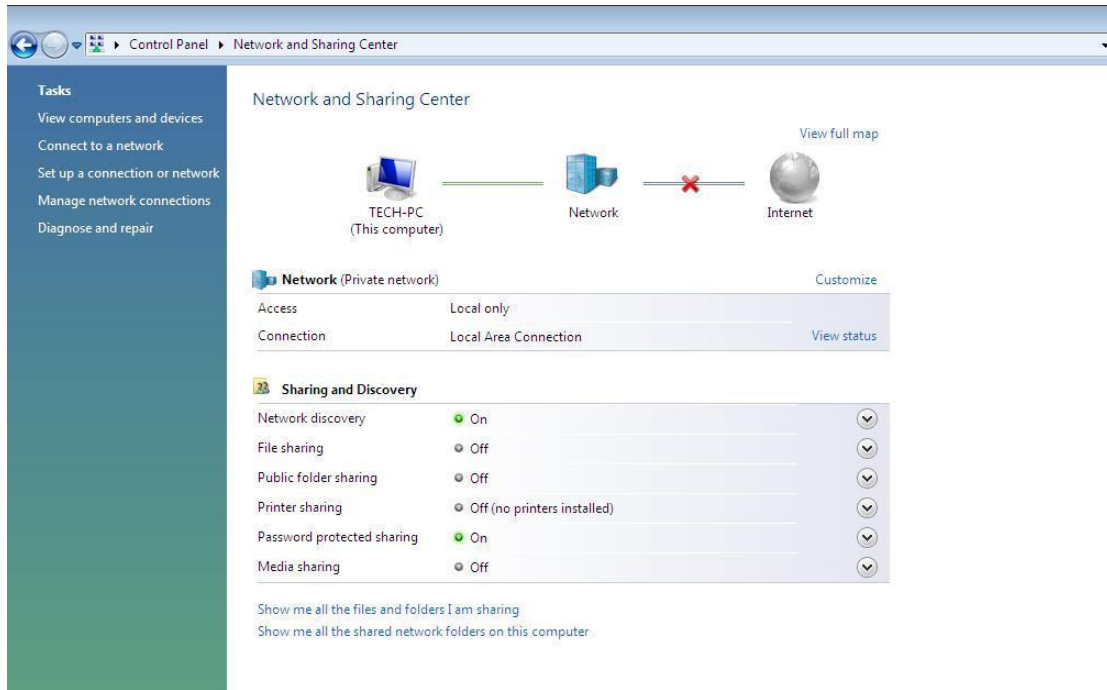

Figure 3-13

4. Highlight the icon Local Area Connection, right click your mouse, and click Properties

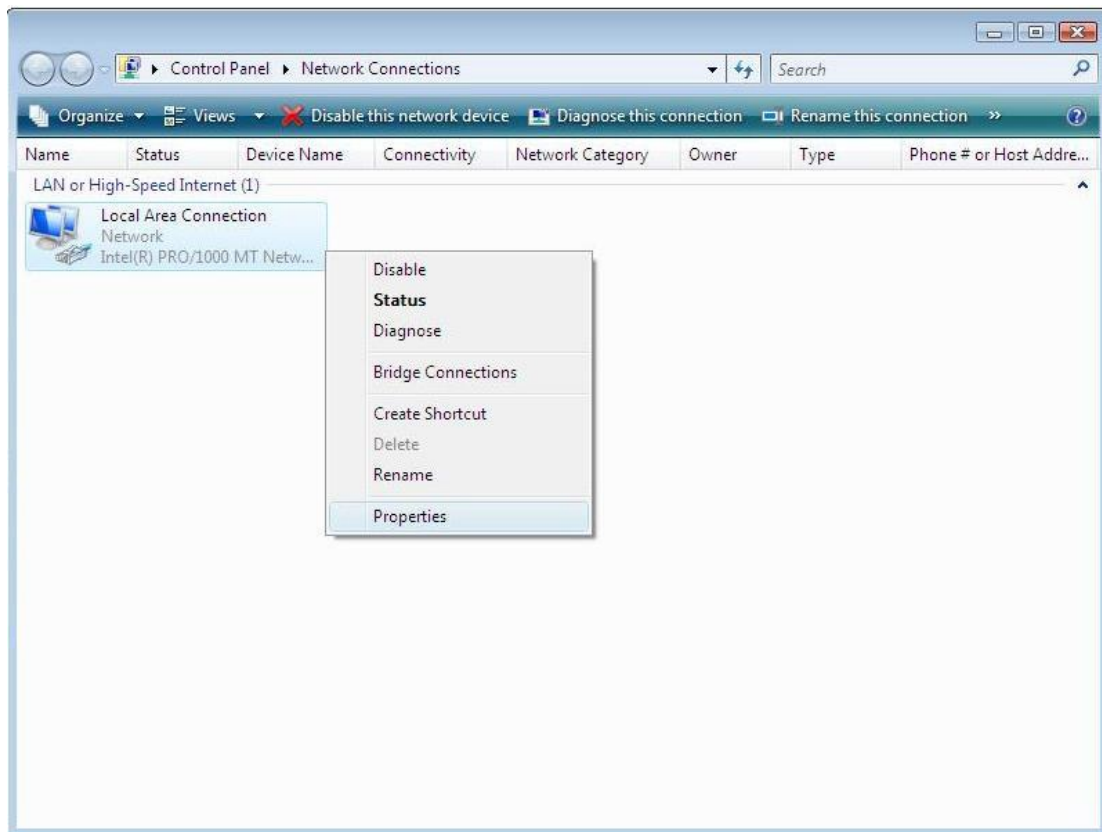

Figure 3-14

5. Highlight Internet Protocol Version 4 (TCP/IP) and then press Properties button

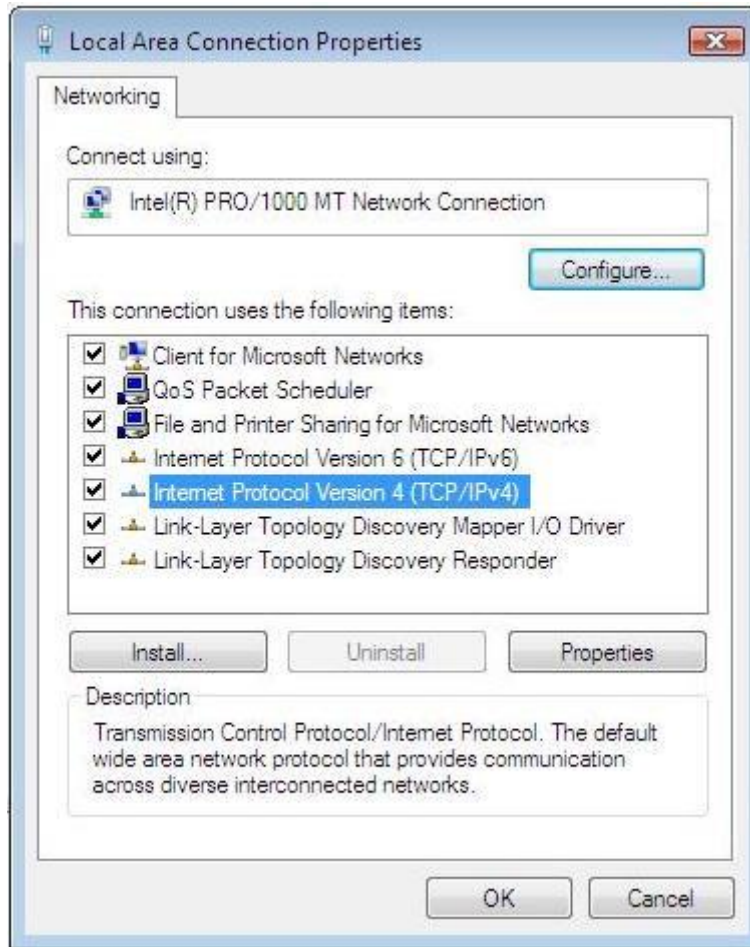

Figure 3-15

6. Choose Obtain an IP address automatically and Obtain DNS server address automatically, and then press OK to close the Internet Protocol (TCP/IP) Properties window

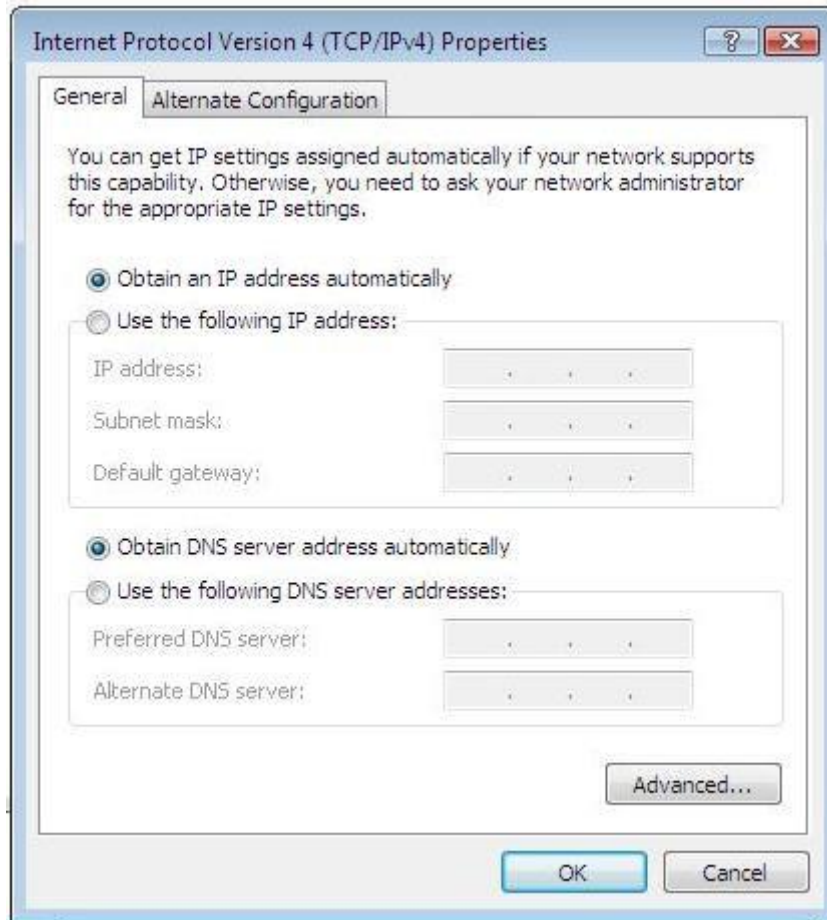

Figure 3-16

7. Press OK to close the Local Area Connection Properties window.

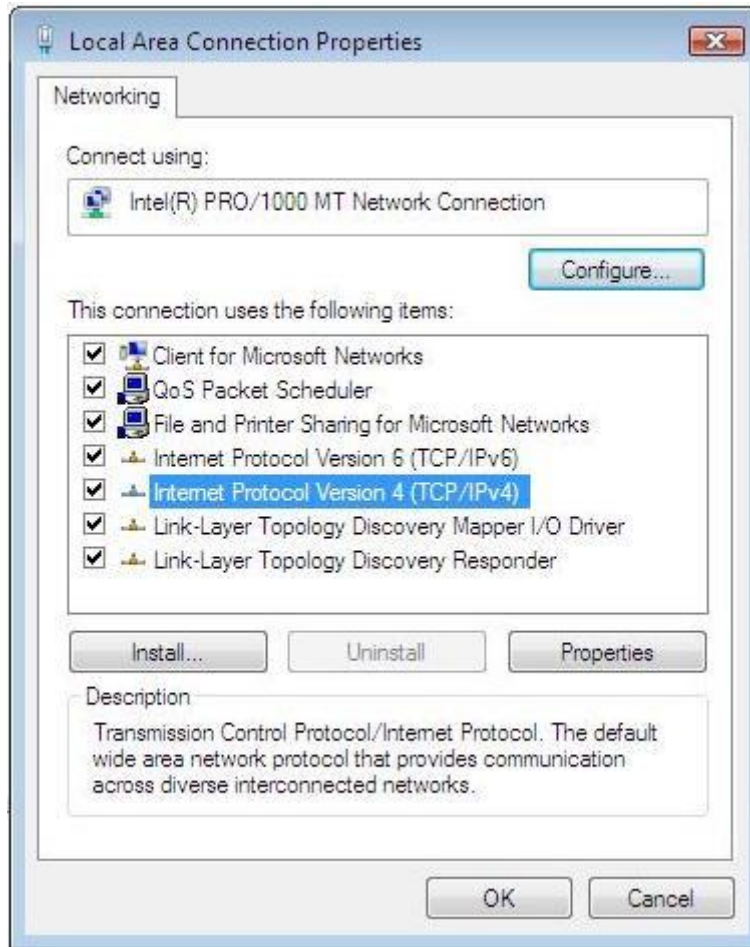

Figure 3-17

3.1.5. Windows 7

Please follow the steps blow to setup your computer :

1. Go to Start→ Control Panel→ Network and Internet.
2. Click Network and Sharing Center→ Change adapter settings.
3. Highlight the icon Local Area Connection, right click your mouse, and click Properties.
Highlight Internet Protocol version 4 (TCP/IPv4).

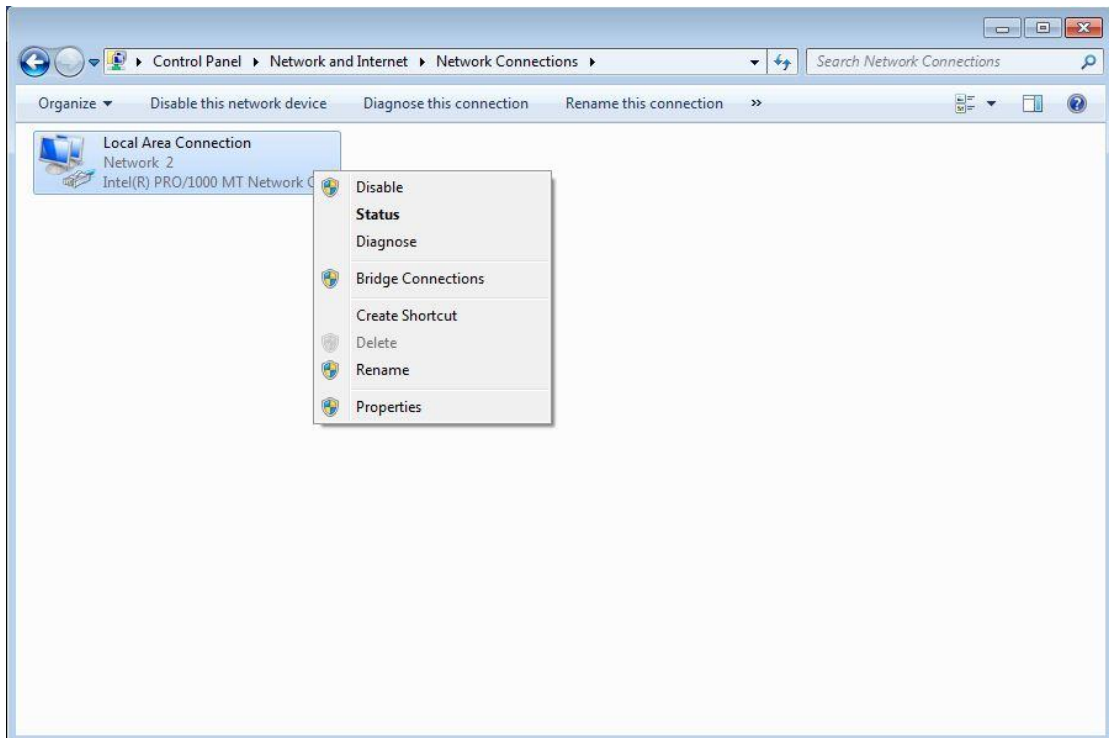

Figure 3-18

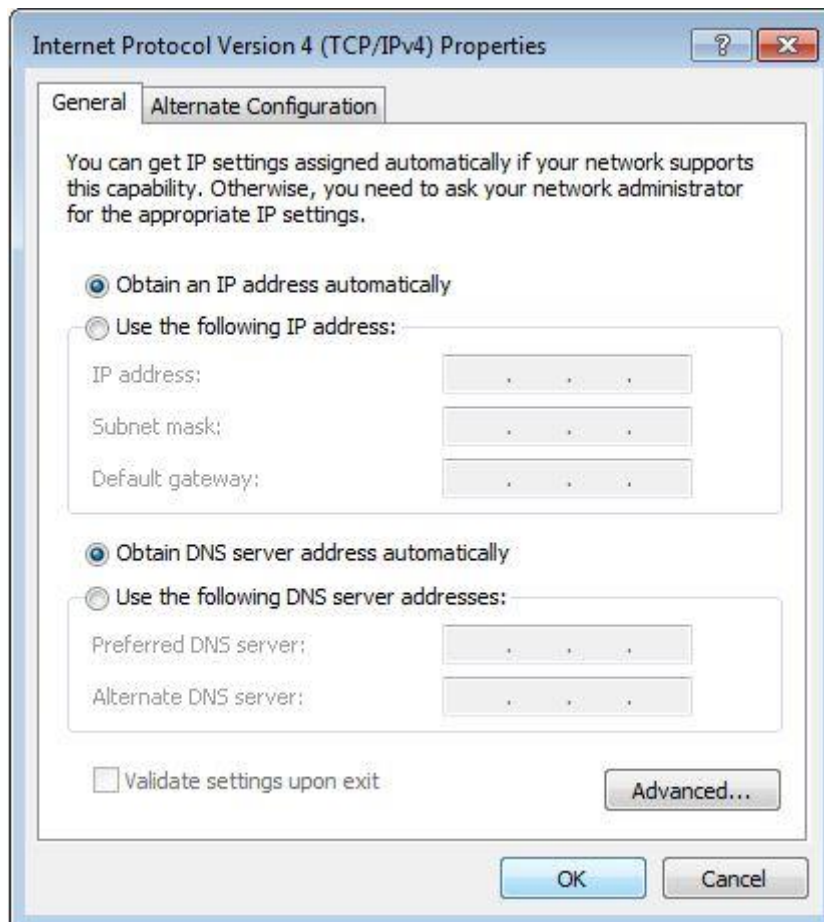

Figure 3-19

4. Choose Obtain an IP address automatically and Obtain DNS server address automatically,

and then press the OK to close the window.

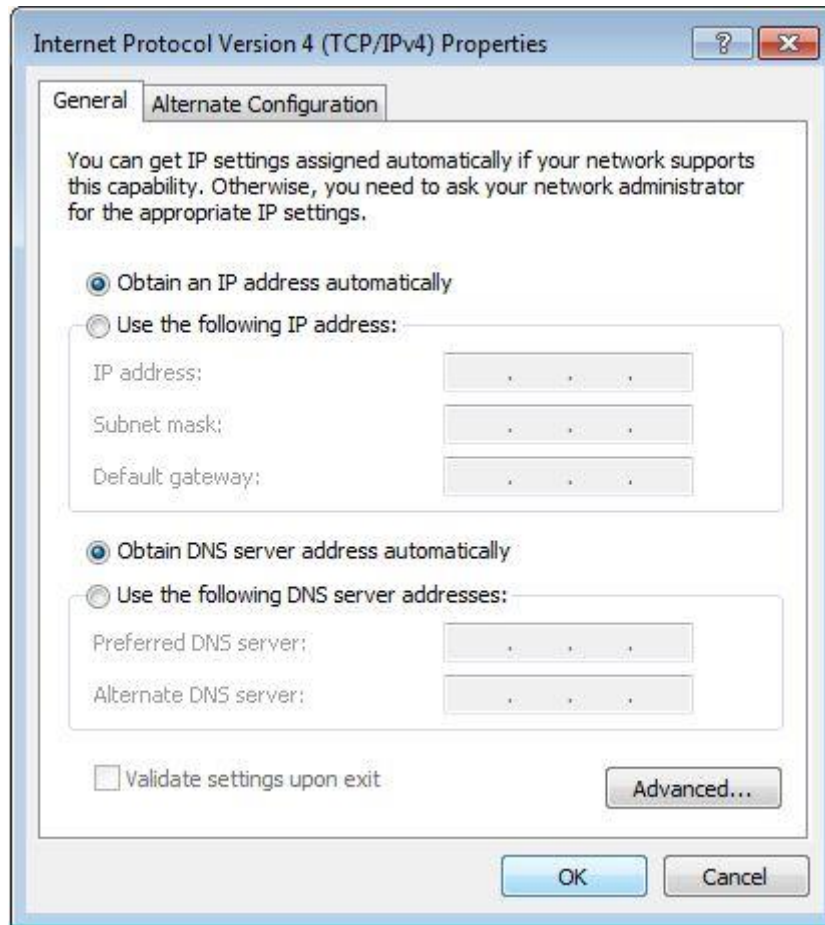

Figure 3-20

5. Press OK to close the Local Area Connection Properties window.

3.1.6. MAC OS

Please follow the steps blow to setup your computer:

1. Go to Start→ System preference Settings→ Network.



Figure 3-21

2. Click Network, Select Use DHCP at the Configuration bar, the system will get the IP address automatically.



Figure 3-22

3. Press Apply to complete this operation and close the window.

3.2. Checking Connection with the Router

After configuring the TCP/IP protocol, use the ping command to verify if the computer can communicate with the Router. To execute the ping command, open the DOS window and Ping the IP address of the 300Mbps Wireless-N Broadband Router at the DOS prompt:

- For Windows 98/Me: Start → Run. Type command and click OK.
- For Windows 2000/XP: Start → Run. Type cmd and click OK.
- For Windows Vista/7: Start → Type cmd at the start search bar and press the Enter.
- For MAC OS → The system will complete this operation automatically.

At the DOS prompt, type the following command:

If the Command window returns something similar to the following:

```
C:\Documents and Settings\admin>ping 192.168.1.1

Pinging 192.168.1.1 with 32 bytes of data:

Reply from 192.168.1.1: bytes=32 time=1ms TTL=64
Reply from 192.168.1.1: bytes=32 time=1ms TTL=64
Reply from 192.168.1.1: bytes=32 time=1ms TTL=64
Reply from 192.168.1.1: bytes=32 time=1ms TTL=64

Ping statistics for 192.168.1.1:
    Packets: Sent = 4, Received = 4, Lost = 0 (0% loss),
    Approximate round trip times in milli-seconds:
        Minimum = 1ms, Maximum = 1ms, Average = 1ms
```

Then the connection between the router and your computer has been successfully established.

If the computer fails to connect to the router, the Command window will return the following:

```
C:\Documents and Settings\admin>ping 192.168.1.1

Pinging 192.168.1.1 with 32 bytes of data:
```

```
Request timed out.  
Request timed out.  
Request timed out.  
Request timed out.  
  
Ping statistics for 192.168.1.1:  
    Packets: Sent = 4, Received = 0, Lost = 4 (100% loss),
```

Verify your computer's network settings are correct and check the cable connection between the router and the computer.

In order to make the whole network operate successfully, it is necessary to configure the 300Mbps Wireless-N Broadband Router through your computer has a WEB browser installed. Please follow up the steps listed below.

3.3. Login

- Open a web browser (Safari, Internet Explorer, etc.) on the computer you have just connected to the router, type `http://192.168.1.1` in the address bar, and press enter

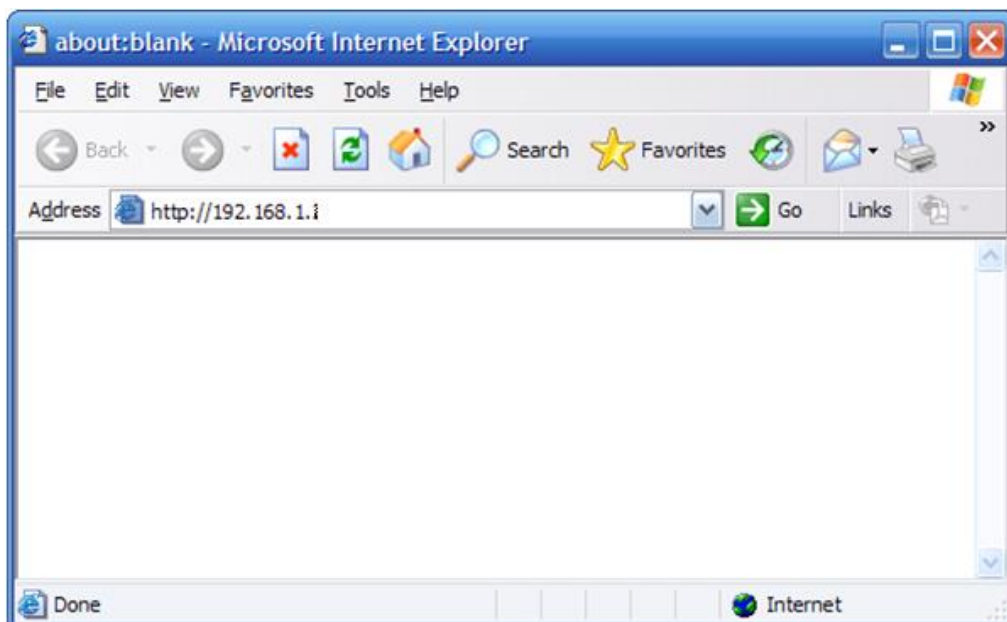

Figure 3-18

- In the pop-up window, enter the user name **guest** and password **guest** and then click OK



Figure 3-19

- After you have logged in, the router's user interface will be displayed. The left menu shows the main options to configure the system, and the right screen is the summary information for viewing and adjusting the configurations.

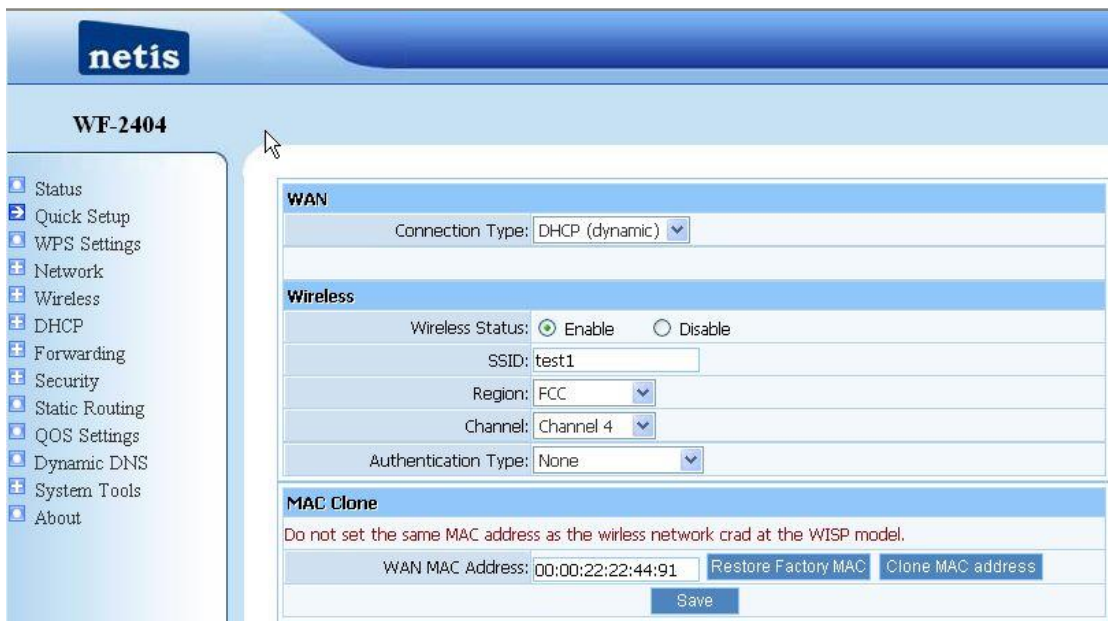

Figure 3-20

4. Router Setup

4.1. Status

This feature provides running status information and detailed information about router.

4.1.1. Version

Show the hardware version and firmware version.

Version	
Hardware Version:	WF-2404
Firmware Version:	APR-R4A4-V1.1.102EN-Netis(WF-2404),2010.11.12 12:30.

Figure 4-1

4.1.2. WAN

This feature provides running status information of the WAN port (the port connect to the Internet)

WAN	
Connection Type:	DHCP
MAC Address:	00:00:22:22:44:91
IP Address:	192.168.175.101
Subnet Mask:	255.255.255.0
Default Gateway:	192.168.175.1
Primary DNS:	192.168.2.1
Secondary DNS:	202.103.24.68
Link Status:	Connect <input type="button" value="Disconnect"/>

Figure 4-2

- **Connection Type:** Display router's current connection type, It should be one of "PPPoE", "DHCP", "Static IP", depending on what kind of connection type your ISP provides.
- **Physical Address:** The physical address of WAN port, this is a unique address assigned by manufacturer.
- **IP Address:** The IP address you obtained after connect to the Internet, if you haven't connected to the Internet yet, this field is 0.0.0.0.
- **Subnet Mask:** The Subnet mask you obtained after connect to the Internet, if you haven't connected to Internet yet, this field is 0.0.0.0

- **Default Gateway:** The IP address of Default gateway you obtained after connect to the Internet, if you haven't connected to Internet yet, this field is 0.0.0.0.
- **Primary DNS:** The DNS server translates domain or website names into IP address, input the most common DNS server address you used or provided by your ISP.
- **Secondary DNS:** Input IP address of a backup DNS server or you can leave this field blank
- **Link Status:** Show the current status of link information. You can choose connect or disconnect by manually.

4.1.3. LAN

This item provides information about router's LAN port, display LAN port's physical address, IP address and current situation of DHCP server.

LAN	
MAC Address:	00:00:22:22:44:90
IP Address:	192.168.10.1
Subnet Mask:	255.255.255.0
DHCP Server:	Enable

Figure 4-3

4.1.4. Wireless

This item provides current running information of wireless.

Wireless	
Wireless Status:	Enable
Name(SSID):	test1
Mode:	AP
Channel:	4
MAC Address:	00:00:22:22:44:90
WPS Status:	Disabled

Figure 4-4

- **Wireless status:** Display wireless interface status is enabled or not
- **Name (SSID):** SSID (Service Set Identifier) is your wireless network's name shared among all points in a wireless network.
- **Mode:** Current wireless mode of wireless router
- **Channel:** Display current channel of your wireless router.
- **MAC Address:** The MAC address is used for wireless communication
- **WPS Status:** Display WPS (Wi-Fi Protected Setup) status is enabled or not.

4.1.5. Router Status

This item provides current running information of System.

Router Status	
System Uptime:	0 Days 5 hours 48 minutes 19 seconds
CPU Usage:	1%
Memory Usage:	5%

Figure 4-5

4.1.6. Traffic Statistics

This item provides statistics information about the bits router sends and received.

Traffic Statistics				
Type	Sending Packets	Receiving Packets	Sending data (KBytes)	Receiving data(KBytes)
LAN	80814	70162	42299	8782
WAN	24309	33908	2518	32401
WLAN	29041	250481	5984	46194

Figure 4-6

4.2. Quick Setup

Providing you the convenient and simplest method for configure the router, the purpose of this item is to provide an easy way for you to use it and configure your router to access the Internet quickly; including 'DHCP (dynamic)', 'PPPoE', 'Static' and 'Wireless Configuration'. This is the most convenient tool for you to configure router.

4.2.1. DHCP (dynamic)

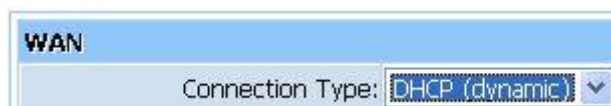

Figure 4-7

After select this item, you will obtain an IP address from your ISP automatically, those ISP who supply Cable modem always use DHCP technology.

4.2.2. PPPoE

WAN	
Connection Type:	PPPoE
Username:	
Password:	

Figure 4-8

If your ISP provides you the PPPoE service (all ISP with DSL transaction will supply this service, such as the most popular ADSL technique), please select this item. In the “Convenient configuration” You can input your PPPoE username and password to access the Internet.

- PPPoE Username: Input PPPoE username provided by ISP
- PPPoE Password: Input PPPoE password provided by ISP.

4.2.3. Static

WAN	
Connection Type:	Static
WAN IP address:	0.0.0.0
Subnet Mask:	0.0.0.0
Default Gateway:	0.0.0.0
Primary DNS:	(Optional)
Secondary DNS:	(Optional)

Figure 4-9

This item should only be used when users use a static IP address to access Internet, you should input your “WAN IP address”, ”subnet mask”, ” default gateway” and “DNS server (domain name server)” according to the information provided by your ISP. And every IP address should be input in appropriate IP field, a IP address only divided into four IP octets by sign“.” is acceptable.

- WAN IP address: The IP address that your Internet access into
- Subnet mask: Specify a Subnet Mask for your WAN segment
- Default gateway: It is provided by your ISP
- Primary DNS: DNS server is used for resolve domain name. Your ISP will provides you with at least one DNS IP address, input IP address of your DNS server in this field
- Secondary DNS: Input IP address of backup DNS server, or you can leave this field blank.

4.2.4. Wireless Configuration

You can choose “Enable” or “Disable” to enable or disable the wireless function. The default setting is “enable”. If you chose the “Disable” status, the router will become a wired broadband router without wireless function, so be careful when you choose this status.

Figure 4-10

- **SSID:** SSID (Service Set Identifier) is your wireless network's name shared among all points in a wireless network. The SSID must be identical for all devices in the wireless network. It is case-sensitive and must not exceed 32 characters. Make sure all points in the wireless network have the same SSID. For added security, you should change the default SSID to a unique name.
- **Region:** Choose a correct region which fit your use environment.
- **Channel:** Wireless router communicates to wireless cards in a particular channel, which can reduce interference between different channels.
- **Authentication Type:** Different authentication types use different encryption types, which can encrypt wireless data to protect your wireless communication.

4.2.5. MAC Clone

The WAN port of router has a unique MAC address assigned by manufacturer; it called as “Default MAC”. The “Clone MAC” is used for some special situations; For example, ISP only allows certain MAC address to access the Internet, thus you can modify your WAN port’s MAC address in accord with the requirement of ISP, avoiding ISP’s detection.

Figure 4-11

4.3. WPS Settings

Wi-Fi Protect Setup (WPS) function can let you create a safety network easily. You can through 'PIN Input Config (PIN)' or 'Push Button (PBC)' to encrypt your network. This router also provides WPS button, you only need to push the WPS button in this router and the wireless network card that support WPS function, then the router will be encrypted to WPA2-AES mode automatically

Note:

If you have configured encryption mode in your router, then when you use this WPS function, please configure the authentication type to none, and then it will be encrypted to WPA2-AES mode automatically. If you don't want to change your authentication type, then when you use this function, the router will be encrypted to the mode that you have configured.

4.3.1. WPS Settings

WPS Settings	
WPS Status: Enable	Disable WPS
AP PIN Code: 22457769	Restore PIN Gen New PIN
Add A New Device:	Add Device

Figure 4-12

- WPS Status: You can use this function to setup the wireless connection between this router and wireless network card. The default is Enable.
- AP PIN Code: This code can mark a wireless product.
- Add A New Device: Add a new device by WPS.

4.3.2. Add a New Device

Add A New Device

Enter the new device's PIN:

Press the button of the new device in two minutes

[Connect](#) [Back](#)

Figure 4-13

- Enter the new device's PIN: This code can mark a wireless product.
- Press the button of the new device in two minutes: New device will send a PIN code to wireless router.

4.3.3. WPS Configuration

Display the encryption information.

WPS Configuration			
Security Mode	Authentication Type	Key Format	Key
None			
Refresh			

Figure 4-14

WPS can connect the wireless adapter and the router in a safe way. If you have a wireless network card which has WPS button, you may set up a safe network via the following methods

Method 1:

1. Push the WPS button in the Router until the WPS LED is flashing several times
2. Push the WPS button in the wireless network card for about 3-5seconds
3. The safe connection will be established automatically

Method 2:

1. Input the PIN code of the adapter's WPS page into the router's WPS configure page, then click 'connect'



Figure 4-15

WPS PIN Settings	
Wireless Host PIN Code	<input type="text" value="35229155"/>
Connect	

Figure 4-16

2. Push the 'PIN Input Config (PIN)' in the Wi-Fi protect setup of the adapter

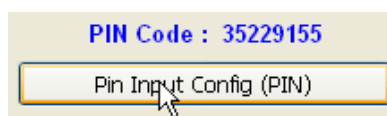

Figure 4-17

3. Select this router in the pop-up window, then click 'Select'
4. The connection between the adapter and the router is be established automatically.

Method 3:

1. Select 'Input PIN from AP' in WI-FI protect setup page, input PIN of the router, then click

‘PIN Input Config (PIN)’

2. Select this router in the pop-up window, then click ‘Select’
3. The connection between the adapter and the router is be established automatically.

Remark

If there is more than one AP in the PBC mode when you use the method 1, there will be session overlap. Please using method 2/3 or wait for a while push the button again.

4.4. Network

4.4.1. WAN

This item provides two access types for you to configure the WAN parameters. They are wired access and wireless access.

4.4.1.1. Wired Access

Access Types	
Access types:	<input checked="" type="radio"/> wired access <input type="radio"/> wireless access
WAN Settings	
Internet Access Type:	DHCP (dynamic) <input type="button" value="Detect"/>
IP :	192.168.175.101
Subnet Mask:	255.255.255.0
Gateway:	192.168.175.1
MTU:	1496
Primary DNS:	<input type="text"/> (Optional)
Secondary DNS:	<input type="text"/> (Optional)
<input type="button" value="Save"/> <input type="button" value="Connection Info"/>	

Figure 4-18

- Internet Access Type: Ask for your ISP to get the correct access type.
- IP: The IP address you obtained after connect to the Internet, if you haven't connected to the Internet yet, this field is 0.0.0.0.
- Subnet Mask: The Subnet mask you obtained after connect to the Internet, if you haven't connected to Internet yet, this field is 0.0.0.0.
- Gateway: The IP address of Default gateway you obtained after connect to the Internet, if you haven't connected to Internet yet, this field is 0.0.0.0.
- MTU: The MTU (Maximum Transmission Unit) setting specifies the largest packet size permitted for network transmission. Most DSL users should use the value 1492. You can

set MTU manually, and you should leave this value in the 1200 to 1500 range. If the value you set is not in accord with the value ISP provide, it may causes some problems, such as fail to send Email, or fail to browse website. So if that happen, you can contact your ISP for more information and correct your router's MTU value.

- Primary DNS: The DNS server translates domain or website names into IP address, input the most common DNS server address you used or provided by your ISP.
- Secondary DNS: Input IP address of a backup DNS server or you can leave this field blank.

4.4.1.2. Wireless Access

Access Types	
Access types:	<input type="radio"/> wired access <input checked="" type="radio"/> wireless access
Wireless Setup	
SSID:	<input type="text"/> <input type="button" value="AP Scan"/>
Authentication Type:	None <input type="button" value="v"/>
WAN Settings	
Internet Access Type:	DHCP (dynamic) <input type="button" value="v"/>
IP :	192.168.175.101
Subnet Mask:	255.255.255.0
Gateway:	192.168.175.1
MTU:	1496
Primary DNS:	<input type="text"/> (Optional)
Secondary DNS:	<input type="text"/> (Optional)
<input type="button" value="Save"/> <input type="button" value="Connection Info"/>	

Figure 4-19

- SSID: SSID (Service Set Identifier) is your wireless network's name shared among all points in a wireless network. The SSID must be identical for all devices in the wireless network. It is case-sensitive and must not exceed 32 characters. Make sure all points in the wireless network have the same SSID. For added security, you should change the default SSID to a unique name.
- Authentication Type: "None" means do not encrypt wireless data.
- Internet Access Type: Ask for your ISP to get the correct access type.
- IP: The IP address you obtained after connect to the Internet, if you haven't connected to the Internet yet, this field is 0.0.0.0.
- Subnet Mask: The Subnet mask you obtained after connect to the Internet, if you haven't connected to Internet yet, this field is 0.0.0.0.
- Gateway: The IP address of Default gateway you obtained after connect to the Internet, if you haven't connected to Internet yet, this field is 0.0.0.0.
- MTU: The MTU (Maximum Transmission Unit) setting specifies the largest packet size permitted for network transmission. Most DSL users should use the value 1492. You can

set MTU manually, and you should leave this value in the 1200 to 1500 range. If the value you set is not in accord with the value ISP provide, it may causes some problems, such as fail to send Email, or fail to browse website. So if that happen, you can contact your ISP for more information and correct your router's MTU value.

- Primary DNS: The DNS server translates domain or website names into IP address, input the most common DNS server address you used or provided by your ISP.
- Secondary DNS: Input IP address of a backup DNS server or you can leave this field blank.

4.4.2. LAN

The IP address of LAN port is used for access router itself by computers that connect to the router directly; here you can set IP address you need. The IP address format is like `***.***.***.***`, and default IP address is 192.168.1.1, the default subnet mask is 255.255.255.0.

LAN	
MAC Address:	00:00:22:22:44:90
IP Address:	192.168.10.1
Subnet Mask:	255.255.255.0
Save	

Figure 4-1

4.4.3. MAC Clone

The WAN port of router has a unique MAC address assigned by manufacturer; it called as "Default MAC". The "Clone MAC" is used for some special situations; For example, ISP only allows certain MAC address to access the Internet, thus you can modify your WAN port's MAC address in accord with the requirement of ISP, avoiding ISP's detection.

MAC Clone	
Do not set the same MAC address as the wireless network card at the WISP model.	
WAN MAC Address:	00:00:22:22:44:91
Restore Factory MAC Clone MAC address	
Save	

Figure 4-21

4.4.4. Port Settings

Here you can set the router's WAN and LAN interfaces work at 100M duplex,100M half-duplex,10M duplex and 10M half-duplex communication mode.

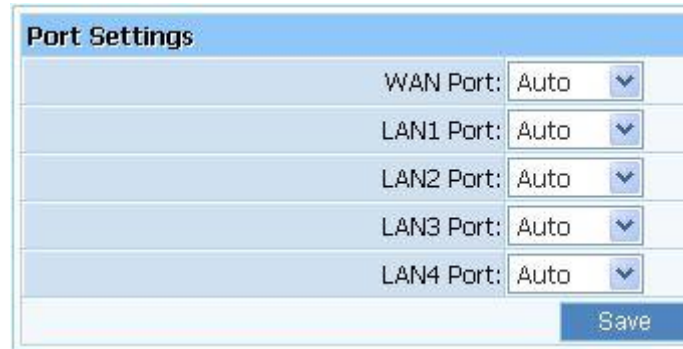

Port Settings	
WAN Port:	Auto
LAN1 Port:	Auto
LAN2 Port:	Auto
LAN3 Port:	Auto
LAN4 Port:	Auto

Save

Figure 4-22

4.4.5. IGMP Proxy

Here you can set the IGMP Proxy 'Enabled' and 'Disabled'.

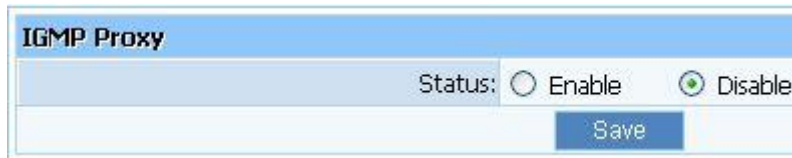

IGMP Proxy

Status: Enable Disable

Save

Figure 4-23

4.5. Wireless

4.5.1. Wireless Settings

Providing basic configuration items for wireless router users, including “wireless network status”, “SSID”, “Radio Band”, “Radio Mode”, “MAC”, “SSID broadcasting”, “Channel width”, “Channel sideband”, “Region” and “Channel” several basic configuration items.

Wireless Settings	
Wireless Status:	<input checked="" type="radio"/> Enable <input type="radio"/> Disable
SSID:	test1
Radio Band:	802.11b+g+n
Radio Mode:	Access Point
MAC:	00:00:22:22:44:90
SSID Broadcast:	<input checked="" type="radio"/> Enable <input type="radio"/> Disable
Channel Width:	<input type="radio"/> 20MHZ <input checked="" type="radio"/> 40MHZ
Control Sideband:	<input checked="" type="radio"/> Lower <input type="radio"/> Upper
Region:	FCC
Channel:	Channel 4
<input type="button" value="Save"/>	

Figure 4-24

- Wireless network status: You can choose “enable” or “disable” to enable or disable the “Wireless Network Status”, if what you choose is “Disable”, the AP function of wireless router will be turned off.
- SSID: The default is trst1.
- Radio band: You can select the wireless standards running on your network, if you have Wireless-N, and Wireless-B/G devices in your network, keep the default setting, 802.11b+g+n
- Radio mode: You can select radio mode of wireless router, it contains Access Point, Client, AP+WDS and WDS. The default setting is AP mode.
- MAC: Wireless router’s physical address.
- SSID Broadcasting: You can select “enable” or “disable” to enable or disable the broadcast SSID function, If the setting of this field is disable, wireless client can’t obtain this SSID to login in, then user have to input the SSID value manually.
- Channel width: This switch allows you to set Router's wireless bandwidth. 20MHZ: In this mode you can get low bandwidth, little interference and slow rate. 40MHZ: In this mode you can get high bandwidth, high interference and rapid rate. Use only when you have a pure router, draft 802.11n wireless network.
- Channel sideband: It controls your wireless router use higher or lower channel when working on 40MHZ.
- Region: please select the region where you live in.
- Channel: In 20MHZ, you can select one channel from 1 to 13 manually, and in 40MHZ, you can select one channel from 1 to 9 or 5 to 13, which provides a choice of avoiding interference.

4.5.2. Wireless Security

The item allows you to encrypt your wireless communication, and you can also protect your

wireless network from unauthorized user access. It supplies “None”, “WEP”, “WPA-PSK”, “WPA2-PSK” and “WPA/WPA2-PSK” five different encryption modes.

4.5.2.1. None

“None” means do not encrypt wireless data.

The screenshot shows the 'Wireless Security' configuration page. At the top, there is a blue header with the text 'Wireless Security'. Below the header, a red message reads: 'For the security of your wireless network, we strongly recommend you to use the encryption of WPA2-AES.' Underneath this message, the 'Authentication Type' is set to 'None' in a dropdown menu. At the bottom of the form, there is a blue 'Save' button.

Figure 4-25

4.5.2.2. WEP

The screenshot shows the 'Wireless Security' configuration page with 'Authentication Type' set to 'WEP'. A red warning message states: 'WPS enable, please not use wep!'. Below this, there are two rows of radio button options: 'Key Length' with '64 bits' selected and '128 bits' unselected; and 'Key Mode' with 'HEX' unselected and 'ASCII' selected. A 'Key' input field is present with a placeholder text: '(please enter any 5 charcters (ASCII charcters:A-Z,a-z,0-9))'. A blue 'Save' button is located at the bottom of the form.

Figure 4-26

- **Key Length:** There are two basic levels of WEP encryption, 64 bits and 128 bits, the more bits password have, the better security wireless network is, at the same time the speed of wireless is more slower.
- **Key Mode:** If you select WEP to encrypt your data, choose the bits of password, it should be 64 bits or 128 bits. Then choose the format of password; it should be HEX or ASCII. The valid character for HEX format should be numbers from 0 to 9 and letters from A to F. HEX support mixed letter and number mode. And ASCII supports all characters that in keyboard.
- **Key Length description:** when you select 64bits, you need to input 10 chars for HEX and 5 chars for ASCII, and when you select 128bits, you need to input 26 chars for HEX and 13 chars for ASCII.

Note: when the WPS is enabled, please not use WEP.

4.5.2.3. WPA-PSK

Wireless Security	
For the security of your wireless network, we strongly recommend you to use the encryption of WPA2-AES.	
Authentication Type:	WPA-PSK
Encryption Type:	<input checked="" type="radio"/> TKIP <input type="radio"/> AES <input type="radio"/> TKIP & AES
Key Mode:	<input type="radio"/> HEX <input checked="" type="radio"/> ASCII
Key:	<input type="text"/> (please enter any 8-63 charcters (ASCII charcters:A-Z,a-z,0-9))
Key Renewal:	86400 seconds(60-86400)
<input type="button" value="Save"/>	

Figure 4-27

- Encryption type: You can select the algorithm you want to use, TKIP, AES or TKIP&AES. TKIP means “Temporal Key Integrity Protocol”, which incorporates Message Integrity Code (MIC) to provide protection against hackers. AES, means “Advanced Encryption System”, which utilizes a symmetric 128-Bit block data.
- Key Renewal: you can configure the renewal time between 60 to 86400 seconds.
- Key Length description: you need to input 8 to 63 ASCII characters no matter which type you select.

4.5.2.4. WPA2-PSK

The WPA2-PSK is similar to WPA-PSK and with stronger encryption method than WPA-PSK, using WPA2-PSK; you should input password (leave this value in the range of 8 to 63 characters) and key renewal time (leave this value in the range of 60 to 86400 seconds).

Wireless Security	
For the security of your wireless network, we strongly recommend you to use the encryption of WPA2-AES.	
Authentication Type:	WPA2-PSK
Encryption Type:	<input checked="" type="radio"/> TKIP <input type="radio"/> AES <input type="radio"/> TKIP & AES
Key Mode:	<input type="radio"/> HEX <input checked="" type="radio"/> ASCII
Key:	<input type="text"/> (please enter any 8-63 charcters (ASCII charcters:A-Z,a-z,0-9))
Key Renewal:	86400 seconds(60-86400)
<input type="button" value="Save"/>	

Figure 4-28

4.5.2.5. WPA/WPA2-PSK

This item mixed WPA-PSK and WPA2-PSK mode, which provides higher security level; you can configure it according with WPA-PSK or WPA2-PSK.

Wireless Security	
For the security of your wireless network, we strongly recommend you to use the encryption of WPA2-AES.	
Authentication Type:	WPA/WPA2-PSK
Encryption Type:	<input checked="" type="radio"/> TKIP <input type="radio"/> AES <input type="radio"/> TKIP & AES
Key Mode:	<input type="radio"/> HEX <input checked="" type="radio"/> ASCII
Key:	<input type="text"/> (please enter any 8-63 charcters (ASCII characters:A-Z,a-z,0-9))
Key Renewal:	86400 seconds(60-86400)
<input type="button" value="Save"/>	

Figure 4-29

4.5.3. Wireless MAC Filtering

Wireless MAC Address Filtering		
Wireless Access Control Status:	<input type="radio"/> Enable <input checked="" type="radio"/> Disable	
Wireless Access Control Rule:	<input type="radio"/> Permit wireless connection for MAC address listed (others are Denied) <input checked="" type="radio"/> Deny wireless connection for MAC address listed (others are Permitted)	
<input type="button" value="Save"/>		
Rule Description		
MAC Address:	<input type="text"/>	
<input type="button" value="Add"/>		
Items show in every single page	3 <input type="button" value="Apply"/> <input type="button" value="Left"/> <input type="button" value="Up"/> <input type="button" value="Down"/> <input type="button" value="Right"/> <input type="button" value="0"/> Total 0 Pages	
ID	MAC Address	Delete

Figure 4-30

- MAC Filter Status: the default is disable. You can filter wired users by enabling this function; thus unauthorized users can not access the network.
- Description: describe MAC Filter list to tell from different MAC Filter lists.
- Rule: you can select permit or deny. The default is permit.
- MAC address: input the MAC address that you want to control. The default format is **_**_**_**_**_** (e.g.: 00-22-33-da-cc-bb) .

Follow the following steps to set MAC filter:

1. Enable MAC Filter, then select save.
2. Add MAC address you want to control in the “MAC address” field (the format is **_**_**_**_**_**), then click “Add” button, and you will see the MAC address has displayed in the MAC list.
3. There are two items supplied, “Permit wireless connection for MAC address listed (others are Denied)” and “Deny wireless connection for MAC address listed (others are Permitted)”.

Select the item you want, and click “Save” button.

4.5.4. WDS Settings

If you have selected WDS or AP+WDS mode in Wireless Basic-Radio Mode, please do the following configurations.

ID	WDS Name	WDS MAC Address	Del

Figure 4-31

- **WDS Name:** Give a description of your wireless bridge to tell apart.
- **WDS MAC Address:** If the current working mode is “WDS” or “AP+WDS”, then you need to configure wireless bridge configuration. Enter MAC address of remote access point, at the same time the remote access point also need to configure to “WDS” or ”AP+WDS” mode.
- **Current WDS Information:** It illustrates basic information of all wireless bridge that in connection status, you may delete unnecessary bridge.

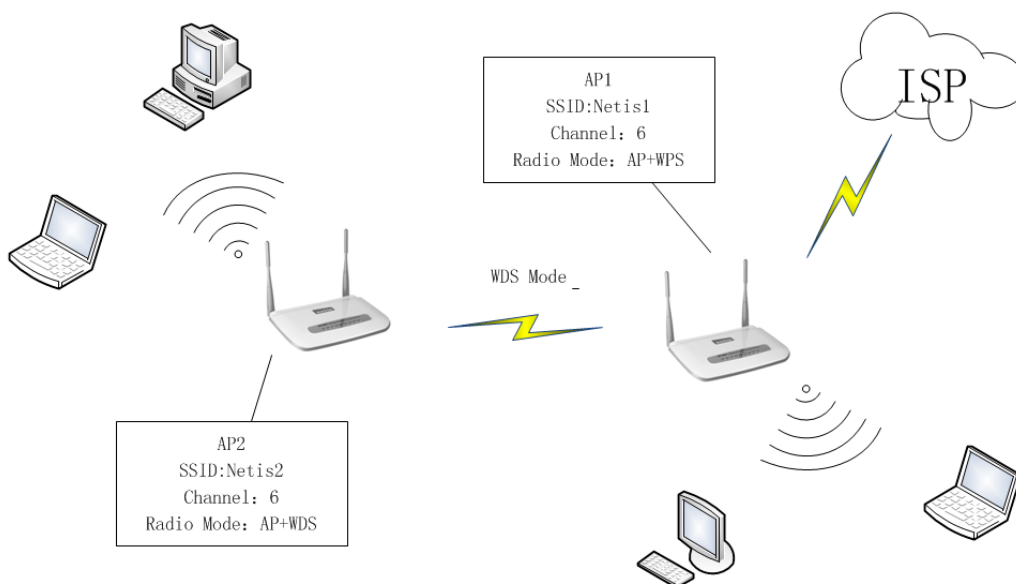

Figure 4-32

AP1:

- Select radio mode is WDS or AP+WDS in wireless management-basic of AP1.
- Click on 'Wireless Management'- 'AP Setup'- 'Security' and select and save None as authentication type.
- Click on 'Wireless Management'- 'AP Setup'- 'Security' and select and save None as WDS authentication type or select a WDS security type, enter key and save.
- Input WDS name (e.g.: default), input MAC address of AP2 (00-22-4f-bc-af-5d), click add, then the record named default will appears in WDS list.
- Select Channel is 'Channel 6'in wireless management-basic of AP2.

AP2:

- Select radio mode is WDS or AP+WDS in wireless management-basic of AP2.
- The IP address of AP2 should be 192.168.1.x (1<x<255,e.g.: x=8).
- Select 'LAN setup'-'DHCP server' ,select disable DHCP server.
- 4. Input WDS name (e.g.: Default), input MAC address of AP1 (00-22-4f-cc-ae-f5), click add, then the record named Default will appears in WDS list.
- Select Channel is 'Channel 6'in wireless management-basic of AP2.

Note: Before you setup WDS connection, please make sure that AP1 and AP2 is in the same network, that is if the IP address of AP1 is 192.168.1.1, then the IP address of AP2 should be 192.168.1.x (1<x<255,e.g.: x=8).

4.5.5. Repeater Settings

Wireless Repeater mode, is used to relay the wireless signal from a relay point to the next point, relay and amplify the signals and form a new wireless coverage area.

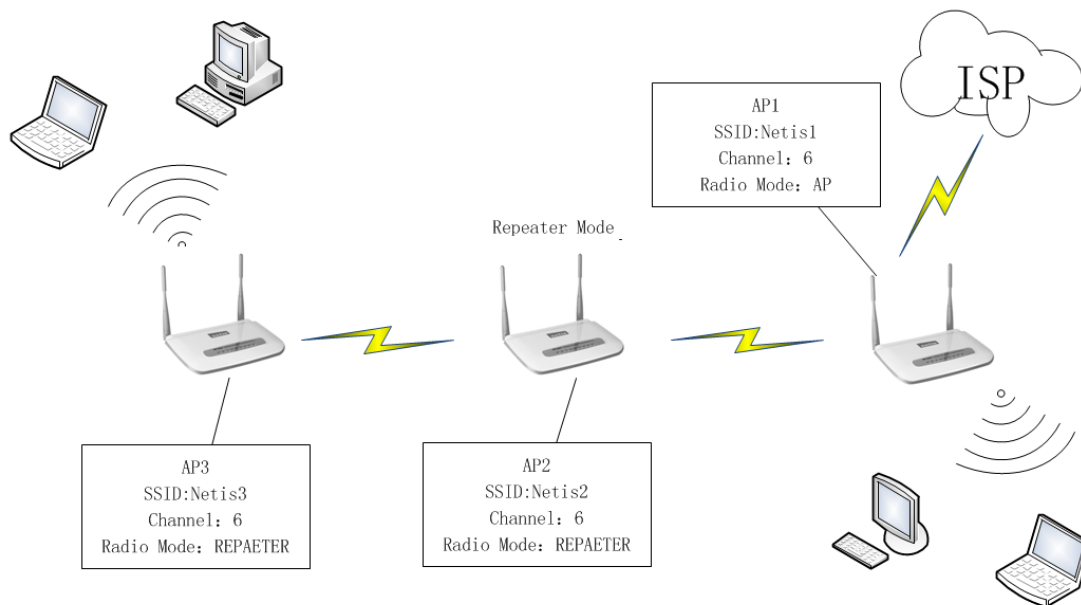

Figure 4-33

AP1:

- Select radio mode is 'Access Point' in wireless management-basic of AP1.
- Select Channel is 'Channel 6' in wireless management-basic of AP1.

Wireless Settings	
Wireless Status:	<input checked="" type="radio"/> Enable <input type="radio"/> Disable
SSID:	netis1
Radio Band:	802.11b+g+n
Radio Mode:	Access Point
MAC:	00:e0:4c:81:96:c1
SSID Broadcast:	<input checked="" type="radio"/> Enable <input type="radio"/> Disable
Channel Width:	<input type="radio"/> 20MHZ <input checked="" type="radio"/> 40MHZ
Control Sideband:	<input checked="" type="radio"/> Lower <input type="radio"/> Upper
Region:	ETSI
Channel:	Channel 6
<input type="button" value="Save"/>	

Figure 4-34

AP2:

- Select radio mode is 'REPEATER' in wireless management-basic of AP2.
- Click 'AP Scan' in wireless management-basic of AP2 ,and select 'Netis1' and Connect , then the 'Repeater SSID' and 'Channel' become same as AP1.
- The IP address of AP2 should be 192.168.1.x (1<x<255,e.g.: x=8).

- Select 'LAN setup'-'DHCP server',select disable DHCP server.

ID	Network Name	BSSID	Channel	Type	Security Type	Signal	Connect
1	Netis1	00:13:13:00:06:41	6 (B+G+N)	AP	no	80%	

Wireless Settings

Wireless Status: Enable Disable

SSID:

Radio Band: ▼

Radio Mode: ▼

MAC:

SSID Broadcast: Enable Disable

Repeater SSID:

Channel Width: 20MHZ 40MHZ

Control Sideband: Lower Upper

Region: ▼

Channel: ▼

Figure 4-35

AP3:

- Select radio mode is 'REPEATER' in wireless management-basic of AP3.
- Click 'AP Scan' in wireless management-basic of AP3 ,and select 'Netis1' and Connect , then the 'Repeater SSID' and 'Channel' become same as AP2.
- The IP address of AP3 should be 192.168.1.x (1<x<255),but different from AP2.
- Select 'LAN setup'-'DHCP server',select disable DHCP server.

4.5.6. Wireless Advanced

These settings are only for more technically advanced users who have a sufficient knowledge about wireless LAN. These settings should not be changed unless you know what effect the change will have on your AP.

Wireless Advanced	
Authentication Type:	Auto <input type="button" value="v"/>
Beacon Interval:	100 <input type="text"/> (Extent:20-1000,Default:100)
RTS Threshold:	2347 <input type="text"/> (Extent:256-2347,Default:2347)
Aggregation:	AMPDU+AMSDU <input type="button" value="v"/>
Fragmentation Threshold:	2346 <input type="text"/> (Extent:256-2346,Default:2346)
Transmission Rate:	Auto <input type="button" value="v"/>
ShortGi:	<input checked="" type="radio"/> Enable <input type="radio"/> Disable
Protection:	<input checked="" type="radio"/> Enable <input type="radio"/> Disable
Preamble Type:	<input checked="" type="radio"/> Long <input type="radio"/> Short
WLAN Partition:	<input type="radio"/> Enable <input checked="" type="radio"/> Disable
IAPP:	<input checked="" type="radio"/> Enable <input type="radio"/> Disable
RF Output Power:	<input checked="" type="radio"/> 100% <input type="radio"/> 70% <input type="radio"/> 50% <input type="radio"/> 35% <input type="radio"/> 15%
WMM:	<input checked="" type="radio"/> Enable <input type="radio"/> Disable
<input type="button" value="Save"/>	

Figure 4-36

- Authentication type: The default is set to “Auto”, which allows “Open System” or “Shared Key” authentication to be used. Select “Shared Key” if you only want to use “Shared Key” authentication (the sender and recipient use a WEP key for authentication).
- Beacon Interval: The interval time of this 150Mbps Wireless-N Broadband Router broadcast a beacon. Beacon is used to synchronize the wireless network. The valid interval is 20-1000, the default is 100.
- RTS Threshold: You can set RTS Threshold value in this field, the valid range should be 256-2347 and default value is 2347. If a network packet is smaller than the preset RTS threshold size, the RTS/CTS mechanism will not be enabled.
- Aggregation: You can accelerate the wireless transmission speed by enabling the aggregation function. The default is AMPDU+AMSDU.
- Fragmentation Threshold: It specifies the maximum size of packet during the fragmentation of data to be transmitted.
- Transmission Rate: Transmit rate indicates the transmission speed of wireless LAN access. The default setting is “Auto” and you can set this value between 1-54Mbps range.
- ShortGi: You can select “Enable” or “disable” for shortgi.
- Protection: Using 802.11b and 802.11g mixed mode may result in poor network performance. By enabling 802.11 protection, it will ameliorate performance of 802.11g devices in your wireless network.

- Preamble Type: "Short Preamble" is suitable for heavy traffic wireless network. "Long Preamble" provides much communication reliability; the default setting is "Long Preamble".

4.5.7. Wireless Statistics

Display current status of the wireless client associate with AP.

Wireless Statistics						
MAC Address	Mode	Tx Packet	Rx Packet	Tx Rate (Mbps)	Power Saving	Expired Time (s)
Refresh						

Figure 4-37

4.5.8. Multiple AP Settings

The default status of secondary AP is disable, you can select enable to enable the secondary AP. Please refer to [Quick Setup Wireless Security](#) and [Wireless Statistics](#) for details.

Multiple AP Wireless Settings	
Wireless Status:	<input type="radio"/> Enable <input checked="" type="radio"/> Disable
Save	

Multiple AP Wireless Security	
For the security of your wireless network, we strongly recommend you to use the encryption of WPA2-AES.	
Authentication Type:	None <input type="button" value="v"/>
Save	

Multiple AP Wireless Statistics						
MAC Address	Mode	Tx Packet	Rx Packet	Tx Rate (Mbps)	Power Saving	Expired Time (s)
Refresh						

Figure 4-38

4.6. DHCP

4.6.1. DHCP Settings

DHCP Settings	
DHCP Server Status:	<input checked="" type="radio"/> Enable <input type="radio"/> Disable
Start IP Address:	<input type="text" value="192.168.10.2"/>
End IP Address:	<input type="text" value="192.168.10.63"/>
Address Lease Time:	<input type="text" value="86400"/> Seconds
<input type="button" value="Save"/>	

Figure 4-39

- DHCP Server Status: Keep the default setting “Enable”, so router is able to use DHCP function. If a DHCP server has already existed in the network, please select “Disable”.
- Start IP Address: The IP Address is used for allocate IP address by DHCP server; enter the start IP address.
- End IP Address: The IP Address is used for allocate IP address by DHCP server; enter the end IP address.

4.6.2. DHCP Clients List

Display the state of assigned IP by DHCP Server.

DHCP Clients List			
Items show in every single page <input type="text" value="3"/>		<input type="button" value="Apply"/>	<input type="button" value="←"/> <input type="button" value="↑"/> <input type="button" value="↓"/> <input type="button" value="→"/> <input type="text" value="1"/> Total 1 Pages
ID	IP Address	MAC Address	Status
1	192.168.10.2	00:1c:c0:a2:d8:e3	Dynamic
2	192.168.10.3	00:e0:4c:07:79:fd	Dynamic

Figure 4-40

4.6.3. Address Reservation

Address Reservation

Auto Setup

MAC Address:

IP Address:

Items show in every single page Total 0 Pages

ID	IP Address	MAC Address	Del
----	------------	-------------	-----

Figure 4-41

- Address Reservation: reserve IP address for designed physical address host. If you want to configure a fixed IP address for some host, please input physical address and IP address, then click add.

4.7. Forwarding

4.7.1. Virtual Servers

Virtual Servers

Description:

Internal Host IP Address:

Protocol: ALL

External Port: -

Internal Port:

Items show in every single page Total 0 Pages

ID	Description	Internal Host IP Address	Protocol	External Port	Internal Port	Del
----	-------------	--------------------------	----------	---------------	---------------	-----

Figure 4-42

- Description: Describe current virtual server item.
- Internal Host IP Address: The “Internal Host IP Address” indicates IP address of the internal host using virtual server.
- Protocol: The protocol item supplies several protocols. For example, if you have web server within LAN, you can select the HTTP template then the router will input port number 80 automatically.
- External Port: Input an extranet port number (the users in Internet can see these ports).
- Internal Port: Input an intranet port number.

4.7.2. Port Triggering

Port trigger module dynamically registers virtual server rules when any IP host generates the packet from the specified trigger protocol and port. Port trigger module use forward protocol type and port number and use the IP address of host that generates the trigger packet when it registers a rule.

ID	Rule Name	Trigger Condition	Forward Condition	Del
----	-----------	-------------------	-------------------	-----

Figure 4-43

- Predefined Trigger Rules: select one of the Predefined Rules.
- Rule Name: describe one Predefined Trigger that you will configure.
- Trigger Protocol: you can select TCP/UDP.
- Trigger Port: you can select a part of ports.
- Forward Protocol: you can select TCP/UDP.
- Forward Port: you can select a part of ports.

4.7.3. DMZ

DMZ opens all the ports of one computer, exposing the computer to the Internet. So it should only be used for some special-purpose, especial for Internet online games. Using this function you can select “DMZ” item and input IP address of DMZ host, then click “Save”. For the purpose of security, we suggested that using “Virtual server” instead of “DMZ”.

DMZ	
DMZ Status:	<input type="radio"/> Enable <input checked="" type="radio"/> Disable
DMZ Host IP Address:	<input type="text" value="0.0.0.0"/>
<input type="button" value="Save"/>	
Super DMZ	
Super DMZ Status:	<input type="radio"/> Enable <input checked="" type="radio"/> Disable
MAC Address:	<input type="text" value="00:e0:4c:07:79:fd"/>
<input type="button" value="Save"/>	

Figure 4-44

4.7.4. UPnP

The UPnP function supports load Application's port forward record automatically. Select "Enable" to enable this function.

UPnP	
UPnP Status:	<input checked="" type="radio"/> Enable <input type="radio"/> Disable
<input type="button" value="Save"/>	

Figure 4-45

4.7.5. FTP Private Port

Some games, servers, and applications (such as BT, QQ video, Edunkey, Web server) are no longer effect when behind the NAT router, so this item provides function of port mapping from LAN to WAN.

FTP Private Port	
Status:	<input type="radio"/> Enable <input checked="" type="radio"/> Disable
Port Number:	<input type="text" value="21"/>
<input type="button" value="Save"/>	

Figure 4-46

4.8. Security

4.8.1. Security Settings

VPN is commonly used for encapsulate and encrypt data across the public network. For VPN

tunnel, the router supports IPSEC pass-through, PPTP pass-through and L2TP pass-through.

VPN Security Settings	
PPTP Pass-through:	<input checked="" type="radio"/> Enable <input type="radio"/> Disable
L2TP Pass-through:	<input checked="" type="radio"/> Enable <input type="radio"/> Disable
IPSEC Pass-through:	<input checked="" type="radio"/> Enable <input type="radio"/> Disable
<input type="button" value="Save"/>	

Figure 4-47

4.8.2. IP Address Filtering

IP Address Filtering								
Status:	<input type="radio"/> Enable <input checked="" type="radio"/> Disable							
Filtering Rules:	<input type="radio"/> Deny through the router for IP address listed, others are permitted <input checked="" type="radio"/> Permit through the router for IP address listed, others are denied							
<input type="button" value="Save"/>								
IP Filter List Management								
Description:	<input type="text"/>							
Rule:	Permit <input type="button" value="v"/>							
Source IP Address:	<input type="text"/>							
Protocol and Port:	All <input type="button" value="v"/> - <input type="text"/>							
Days To Block:	<input type="checkbox"/> Everyday <input type="checkbox"/> Sun <input type="checkbox"/> Mon <input type="checkbox"/> Tue <input type="checkbox"/> Wed <input type="checkbox"/> Thu <input type="checkbox"/> Fri <input type="checkbox"/> Sat							
Times To Block:	<input type="checkbox"/> All Day <input type="text" value="00:00"/> - <input type="text" value="00:00"/>							
<input type="button" value="Add"/>								
Items show in every single page <input type="text" value="3"/> <input type="button" value="Apply"/> <input type="button" value="←"/> <input type="button" value="↑"/> <input type="button" value="↓"/> <input type="button" value="→"/> <input type="text" value="0"/> Total 0 Pages								
ID	Description	Source IP	Destination Port	Protocol	Days To Block	Times To Block	Rule	Del
<input type="button" value="Del All"/>								

Figure 4-48

- Status: the default is disable. The rules of “Internet access control” based on source IP, port number and protocol.
- Description: describe IP Firewall list to tell from different IP Firewall lists.
- Rule: you can select permit or deny. The default is permit.
- Source IP address: input the source IP address that you want to control. The default format is *.*.*.*.*.*.*.*.*(e.g: 192.168.2.3).
- Protocol and Port: If the rule has already existed in “Protocol Template”. You can select appropriate item and apply it. Or you can input protocol type and port number manually, click “add” button, then the item will displayed in the list.

Follow the following steps to set Internet Access Control:

1. You can select “enable” and click “Save” to enable “IP Firewall” function. This is only the first step, you should continued to create appropriate rules for “IP Firewall”.
2. Input description information for current access control rule in the “Description” field. Input IP address of host you want to restrict.
3. There are two items supplied, “Permit through the router for IP address listed, others are denied” and “Deny through the router for IP address listed, others are permitted”, Select the item you want, and click “Save” button.
4. If you want to delete certain item on the list, select appropriate item on the list, click “delete” to delete it.

4.8.3. MAC Filtering

Figure 4-49

- Status: the default is disable. You can filter wired users by enabling this function; thus unauthorized users can not access the network.
- Description: describe MAC Filter list to tell from different MAC Filter lists
- Rule: you can select permit or deny. The default is permit
- MAC address: input the MAC address that you want to control. The default format is **_**_**_**_**_** (e.g.: 00-22-33-da-cc-bb)

Follow the following steps to set MAC filter:

1. Enable MAC Filter, then select save.

2. Add MAC address you want to control in the “MAC address” field (the format is **_**_**_**_**_**_**), then click “Add” button, and you will see the MAC address has displayed in the MAC list.
3. There are two items supplied, “Permit wireless connection for MAC address listed (others are Denied)” and “Deny wireless connection for MAC address listed (others are Permitted)”, Select the item you want, and click “Save” button.

4.8.4. Domain Filtering

Figure 4-50

- Status: the default is disable. “DNS filter” is able to filter certain domain name such as www.sina.com.
- Rule: you can select permit or deny. The default is permit.
- DNS Filter Key words: Input website name or Domain name in the “DNS Key Words” field, such as www.163.com.

Follow these steps to set DNS filter:

1. You can select “enable” and click “Save” to enable “DNS Filter” function. This is only the first step, you should continued to create appropriate rules for “DNS Filter”.
2. Input DNS Filter Key words.
3. There are two items supplied, “Permit through the router for DNS Key words listed, others are denied” and “Deny through the router for DNS Key words listed, others are permitted”, Select the item you want, and click “Save” button.
4. If you want to delete certain item on the list, select appropriate item on the list, click “delete”

to delete it.

4.9. Static Routing

Most of broadband router and wireless router are using NAT mode, so this feature is designed for most common network environment.

ID	Type	Dst IP address	Mask	Next-hop address	Del

Figure 4-51

- Destination Network or IP Address: Specify a certain destination Network or IP address which static route forward to.
- Subnet Mask: Subnet mask is used for distinguish Network portion and Host portion for an IP address.
- Next-hop IP Address: This is an IP address of the next-hop device (and also is the gateway address for local host) that allows forwarding data between router and remote network or host.

Routing Table: You can check out all current route items, click “delete” button to delete an route item existed in routing table.

4.10. QOS Settings

QoS Configuration							
Status:	<input type="radio"/> Enable <input checked="" type="radio"/> Disable						
Uplink Speed Setup:	<input type="radio"/> Automatic Uplink Speed <input checked="" type="radio"/> Manual Uplink Speed <input type="text" value="0"/> (KB/s)						
Downlink Speed Setup:	<input type="radio"/> Automatic Downlink Speed <input checked="" type="radio"/> Manual Downlink Speed <input type="text" value="0"/> (KB/s)						
<input type="button" value="Save"/>							
QoS Rule Setting							
Comment:	<input type="text"/>						
IP Address:	192.168.10. <input type="text"/> - 192.168.10. <input type="text"/>						
Guaranteed minimum bandwidth:	Uplink Bandwidth (KB/s) <input type="text" value="0"/> Downlink Bandwidth (KB/s) <input type="text" value="0"/>						
Restricted maximum bandwidth:	Uplink Bandwidth (KB/s) <input type="text" value="0"/> Downlink Bandwidth (KB/s) <input type="text" value="0"/>						
<input type="button" value="Add"/>							
Items show in every single page	<input type="text" value="3"/> <input type="button" value="Apply"/> <input type="button" value="Previous"/> <input type="button" value="Home"/> <input type="button" value="Refresh"/> <input type="button" value="Next"/> <input type="text" value="0"/> Total 0 Pages						
ID	Comment	IP Address	Guaranteed minimum bandwidth		Restricted maximum bandwidth		Delete
			Uplink Bandwidth	Downlink Bandwidth	Uplink Bandwidth	Downlink Bandwidth	

Figure 4-52

- Status: QOS switch.
- Automatic Uplink Speed: Router adjusts uplink bandwidth automatically.
- Manual Uplink Speed (Kbps): User configures uplink bandwidth manually.
- IP Address: Set the IP address range for restricted hosts.
- Minimum bandwidth: setup uplink and downlink bandwidth.
- Maximum bandwidth: setup uplink and downlink bandwidth.

4.11. Dynamic DNS

The DDNS feature allows you using domain name (not IP address) to access Internet. Before you can use this feature, you need to register an account for DDNS service at DDNS service providers, such as “roay.cn”, “TZO.com”, “DynDNS”. For more information, you can visit <http://www.oray.net/Help>.

Figure 4-53

- DDNS Status: Current status of DDNS server.
- DDNS Server Provider: For example, if you want to use service of “roay.cn”, you have to first register and accounts for it. Other DDNS service providers as the same.
- Username, Password, Dynamic Domain Name: After register an DDNS account from DDNS service providers, you will get “User Name”, “Password”, ”Dynamic Domain Name”, Input information in appropriate field.

4.12. System Tools

System management includes password setup, web Setup, upgrade, reboot, restore, WOL and System time

4.12.1. Firmware

Click "Browse..." button and select a File to upgrade, after you have selected the appropriate file, click "Upgrade" button to execute upgrade procedure. Do not cut off the power supply during the process of upgrading.

Figure 4-54

4.12.2. Time Settings

You can choose the time server and the time zone for the system time.

Time Settings	
Current Time:	11/18/2010 14:50:40
GMT:	(GMT+08:00) Beijing, Hongkong, Singapore, Taipei
<input type="button" value="Save"/> <input type="button" value="Refresh"/>	

Figure 4-55

4.12.3. Password

The default username/password is guest/guest. To ensure the Router's security, it is suggested that you change the default password to one of your choice, here enter a new password and then Re-enter it again to confirm your new password. Click "Save" button to save settings.

Password	
Old Username:	guest
Old Password:	<input type="text"/>
New User name:	<input type="text"/>
New Password:	<input type="text"/>
Confirm New Password:	<input type="text"/>
<input type="button" value="Save"/>	

Figure 4-56

4.12.4. WOL

Input host MAC address, and then click button of "Wake up" to wake up the target host which in the LAN.

WOL	
Host MAC Address:	00:00:00:00:00:00
<input type="button" value="Wake Up"/>	

Figure 4-57

4.12.5. System Logs

Examine system logs. You can configure items shown in one Page, the default is 10.

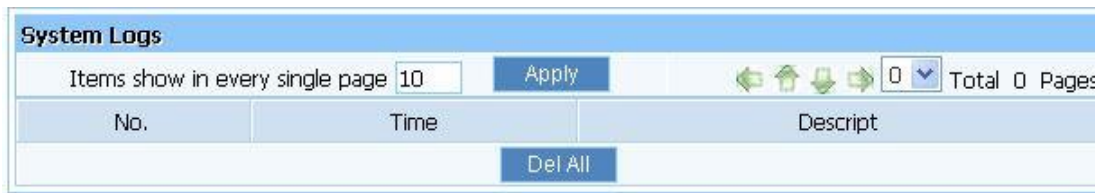

Figure 4-58

4.12.6. Remote Management

WEB Management Status: the default is disable. Router can be accessed on the remote site using “Web setup”. Check the “Management Port” and enter the port number and then press “save” button to enable web management.

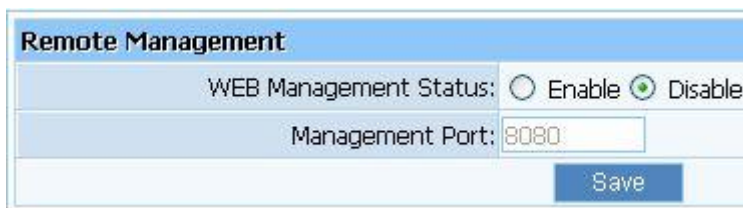

Figure 4-59

4.12.7. Factory Defaults

Click "Restore" button, the Router will erase all of your settings and replace them with the factory defaults, make sure you have backup current settings before click this button.

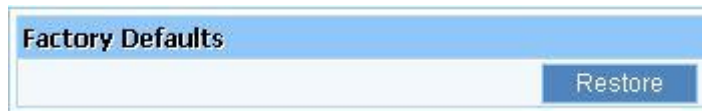

Figure 4-60

4.12.8. Reboot

Click “Reboot” button to restart the router.

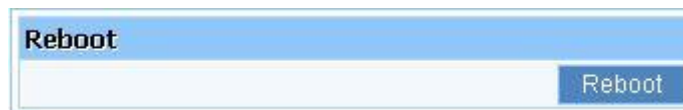

Figure 4-61

4.13. About

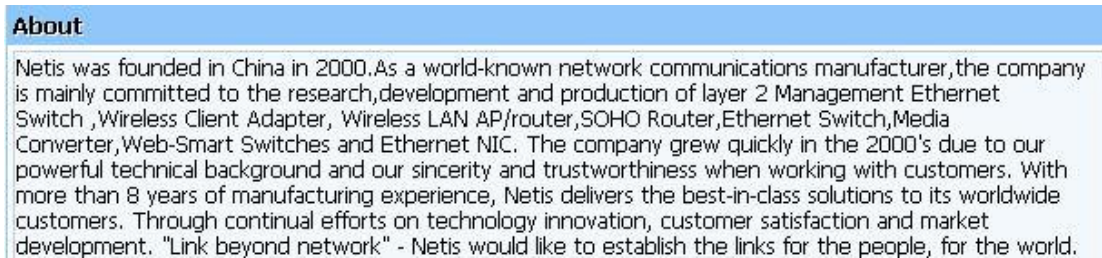

Figure 4-62

Thank you for your support.

5. Troubleshooting

1) I cannot access the Web-based Configuration Utility from the Ethernet computer used to configure the router.

- Check that the LAN LED is on. If the LED is not on, verify that the cable for the LAN connection is firmly connected.
- Check whether the computer resides on the same subnet with the router's LAN IP address.
- If the computer acts as a DHCP client, check whether the computer has been assigned an IP address from the DHCP server. If not, you will need to renew the IP address.
- Use the ping command to ping the router's LAN IP address to verify the connection.
- Make sure your browser is not configured to use a proxy server.
- Check that the IP address you entered is correct. If the router's LAN IP address has been changed, you should enter the reassigned IP address instead.

2) I forget Password (Reset the Router without Login)

- Use a pencil to press the button for about 2-6 seconds when it is working, then leave your hands, it will restore settings to the factory configuration. The default password is **guest**.

3) I have some problems related to Connection with Cable Modem

Please follow the following steps to check the problems:

- Check whether the DSL modem works well or the signal is stable. Normally there will be some indicator lights on the modem, users can check whether the signal is ok or the modem works well from those lights. If not, please contact the ISP.
- Check the front panel of the Router, there are also some indicator lights there. When the physical connection is correct, the Power light and the CPU light should be solid; the WAN light should be blinking. If you use your computer, the corresponding LAN port

light should be blinking too. If not, please check whether the cables work or not.

- Repeat the steps in **WAN Setup** Connect with Internet through DSL Modem.
- 4) I can browse the router's Web-based Configuration Utility but cannot access the Internet.**
- Check if the WAN LED is ON. If not, verify that the physical connection between the router and the DSL/Cable modem is firmly connected. Also ensure the DSL/Cable modem is working properly.
 - If WAN LED is ON, open the System Overview page of the Web configuration utility and check the status group to see if the router's WAN port has successfully obtained an IP address.
 - Make sure you are using the correction method (Dynamic IP Address, PPPoE, or Static IP) as required by the ISP. Also ensure you have entered the correct settings provided by the ISP.
 - For cable users, if your ISP requires a registered Ethernet card MAC address, make sure you have cloned the network adapter's MAC address to the WAN port of the router. (See the **MAC Address** field in **WAN Setup**.)
- 5) My wireless client cannot communicate with another Ethernet computer.**
- Ensure the wireless adapter functions properly. You may open the Device Manager in Windows to see if the adapter is properly installed.
 - Make sure the wireless client uses the same SSID and security settings (if enabled) as the 300Mbps Wireless-N Broadband Router.
 - Ensure that the wireless adapter's TCP/IP settings are correct as required by your network administrator.
 - If you are using a 802.11b wireless adapter, and check that the **802.11G Mode** item in **Wireless Basic Setting** page, is not configured to use 802.11G Performance.
 - Use the ping command to verify that the wireless client is able to communicate with the router's LAN port and with the remote computer. If the wireless client can successfully ping the router's LAN port but fails to ping the remote computer, then verify the TCP/IP settings of the remote computer.